

# Champion®

The Dishwashing Machine Specialists

Project \_\_\_\_\_  
 Item No. \_\_\_\_\_  
 Quantity \_\_\_\_\_

UH130B UNDERCOUNTER

## STANDARD FEATURES

- **NEW "Shear Energy"** – a reduction in energy requirements while maximizing performance!
- **NEW "Multi-Power"** – includes **"Multi-Volt"** and **"Multi-Phase"**. Allows for infield conversion to 208-240 volt and/or single to three phase with ease.
- **StemSure™** – Soft start to protect glasses and dishes from chipping and breaking
- **Rinse Sentry** – extends the cycle time to ensure 180°F final rinse.
- Built-in electric booster for 180°F final rinse water (standard 40°F/4°C or optional 70°F/21°C rise)
- Pumped drain
- Door safety switch
- Low-water tank heat protection
- Detergent and rinse aid pumps
- Quiet double-wall construction
- 15-3/4" door opening to accept larger wares, including trays
- Stainless steel top and side panels
- 141 second cycle
- Wash pump, 1 Hp motor
- Fill and dump
- Prime switch on control panel
- Automatic tank fill
- Advanced Digital Temperature Monitoring
- One year parts and labor warranty

## UH130B

Undercounter High Temperature Dishwashing Machine with Built-in Booster Heater  
**UH130** Model without Booster Heater



**NEW FEATURES**



## OPTIONS & ACCESSORIES

- 1-RDT Dish Table** Durable, heavy-gauge stainless steel dish table with sink, stand-pipe drain, removable scrap screen holder, drain-board, backsplash and lower storage cabinet. Sprayhose is optional. See 1-RDT catalog sheet. Specify right hand or left hand sink.
- Additional Dish Racks**
- 17" Stand**  
Stainless Steel
- 6" Leg Stand**
- 70°F Rise Booster**
- 3 Phase Connection (prewired at factory)**
- UH130B without Booster**
- 1" Roller Kit ( includes 4 casters)**

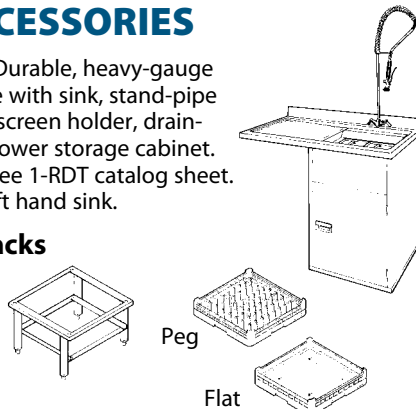

## SPECIFIER STATEMENT

Specified unit will be Champion model UH130B undercounter high temperature dishwashing machine with built-in booster heater.

Features 141 second total cycle, Rinse Sentry, detergent and rinse aid pump, stainless steel top and side panels. Constructed of stainless steel.

1 year parts and labor warranty.

Champion Industries, Inc.  
 3765 Champion Blvd, Winston-Salem, NC 27105  
 Tel: 336/661-1556 Fax: 336/661-1979  
[www.championindustries.com](http://www.championindustries.com)

# UH130B

Undercounter High Temperature Dishwashing Machine with Built-in Booster Heater

**Champion**<sup>®</sup>  
The Dishwashing Machine Specialists

Volume crated: **15 cu. ft.**  
Shipping weight crated: **215 lbs.**

Dimensions shown in inches and [millimeters]

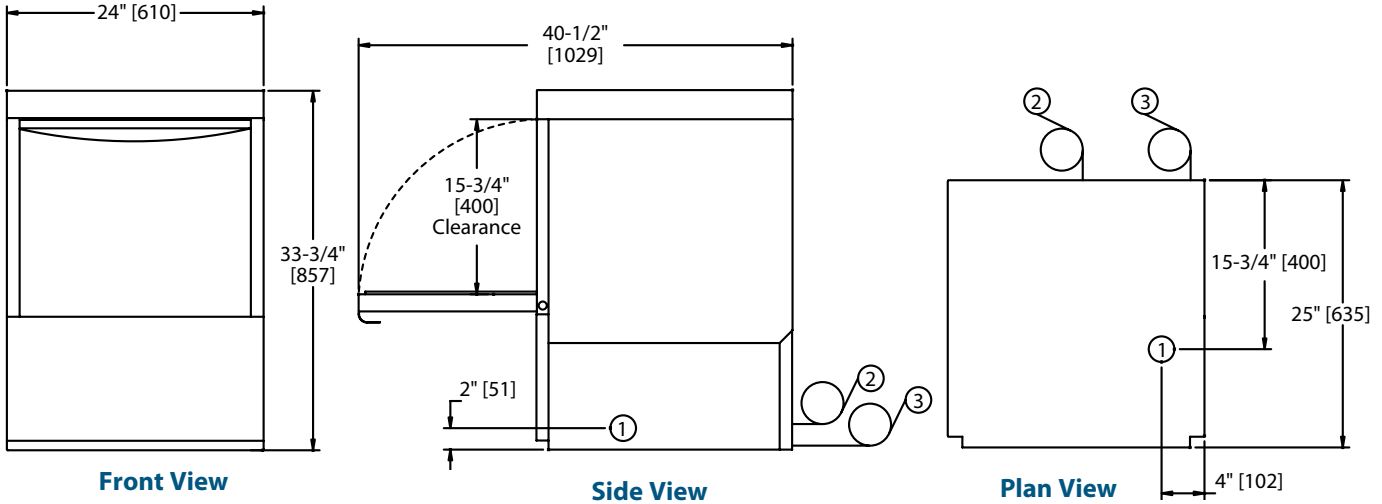

Utilities	
<b>1</b>	<b>Electrical</b> 208-240/60/1; 3 wire plus ground, (See Box). 208-240/60/3; 4 wire plus ground, (See Box). Field convertible to accept 3 phase power, see service manual for details
<b>2</b>	<b>Hot Water</b> 1/2" supply; 140°F/60°C Min. hot water connection for 40°F/22°C rise booster; 110°F/43°C Min. hot water connection for 70°F/39°C rise booster. Incoming supply pressure must maintain a Flow pressure 20-22 PSI (Pressure reducing valve, PRV, supplied by customer or may be purchased unmounted from Champion). Machine equipped with 3/4" [19] hose connector.
<b>3</b>	<b>Pumped Drain</b> 5/8" [15.9] I.D. flexible reinforced hose, 6 ft. [1829] long. Max. drain flow 15 US gpm. [12.5 imp gal] Max. drain height 3 ft. [914]

**Warning** Plumbing and electrical connections should be made by qualified personnel who will observe all the applicable plumbing, sanitary and safety codes and the National Electrical Code.

**UH130B with 40°F/22°C Rise Booster**

Elec. Specs.	Rated Amps	Minimum Supply Ckt. Conductor Ampacity	Maximum Overcurrent Protective Device
208/60/1	32	40	40
240/60/1	36	40	40
208/60/3	22	30	30
240/60/3	24	30	30

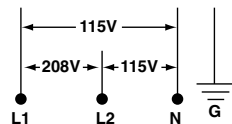

**\*Note:** Electrical supply service must be a 3-wire plus ground for connection as shown.

**UH130B with 70°F/39°C Rise Booster**

Elec. Specs.	Rated Amps	Minimum Supply Ckt. Conductor Ampacity	Maximum Overcurrent Protective Device
208/60/1	45	60	60
240/60/1	50	60	60
208/60/3	29	35	35
240/60/3	33	40	40

UH130B without booster 750 Watt tank heat	
Elec. Specs.	Rated Amps
115/60/1	12

## SPECIFICATIONS

<b>Capacity</b>	
Racks per hr.	25
Cycle time (seconds)	141
<b>Motor horsepower</b>	
Wash	1
<b>Water consumption</b>	
U.S. Gal./Imperial Gal. (Max. use) per hr.	38/31.7
U.S. Gal./Imperial Gal. per rack	1.8/1.5
<b>Temperatures °F/°C</b>	
Wash	150/66
Rinse	180/82
<b>Heating</b>	
Tank heat, electric, kW	2.0
Electric booster (kW) required for 40°F/22°C rise	6
Electric booster (kW) required for 70°F/39°C rise	9
<b>Time cycle in seconds</b>	
Wash	90
Rinse	26
Drain/fill	25
Total cycle	141
<b>Standard 20" x 20" rack complement</b>	
Dish	1
Open	1

Due to an ongoing value analysis program at Champion, specifications contained in this catalog are subject to change without notice.

Champion Industries, Inc., 3765 Champion Blvd, NC 27105 • 336/661-1556 • Fax: 336/661-1979 • www.championindustries.com