

# Champion®

The Dishwashing Machine Specialists

Project \_\_\_\_\_  
 Item No. \_\_\_\_\_  
 Quantity \_\_\_\_\_

UH230B UNDERCOUNTER

## STANDARD FEATURES

- **ENERGY STAR® Qualified**
- **NEW "Shear Energy"** – a reduction in energy requirements while maximizing performance!
- **NEW "Multi-Power"** – includes **"Multi-Volt"** and **"Multi-Phase"**. Allows for infield conversion to 208-240 volt and/or single to three phase with ease.
- **Wash Refresh™** – Fresh water rinse
- **StemSure™** – Soft start to protect glasses and dishes from chipping and breaking
- Rinse Sentry – extends the cycle time to ensure 180°F/82°C final rinse.
- Built-in electric booster for 180°F/82°C final rinse water (standard 40°F/22°C or optional 70°F/39°C rise)
- Pumped drain
- Low-water tank heat protection
- Detergent and rinse aid pumps
- Quiet double-wall construction
- Door safety switch
- Independent stainless steel interchangeable upper and lower wash and rinse arms
- Top mounted slide-out controls
- Stainless steel top and side panels
- 90-second total cycle time
- Extended wash for difficult ware cleaning & de-liming
- Automatic drain cycle
- 1 Hp motor
- Advanced Digital Temperature Monitoring
- Stainless steel construction

## UH230B

Undercounter High Temperature Dishwashing Machine with Built-in Booster Heater

**UH230** Model without Booster Heater



**NEW FEATURES**



## SPECIFIER STATEMENT

Specified unit will be Champion model UH230B undercounter high temperature dishwashing machine with built-in booster heater.

Features 90 second total cycle, extended wash, LED temp display, Rinse Sentry, rinse aid and detergent pumps, flexible fill and drain hoses, stainless steel top and side panels. Constructed of stainless steel.

1 year parts and labor warranty.

## OPTIONS & ACCESSORIES

**1-RDT Dish Table** Durable, heavy-gauge stainless steel dish table with sink, stand-pipe drain, removable scrap screen holder, drain-board, backsplash and lower storage cabinet. Sprayhose is optional. See 1-RDT catalog sheet. Specify right hand or left hand sink.

**Additional Dish Racks**

**17" Stand**  
Stainless Steel

**6" Leg Stand**

**3 Phase Connection (prewired at factory)**

**70°F/39°C Rise Booster**

**UH230B without Booster**

**1" Roller Kit (includes 4 casters)**

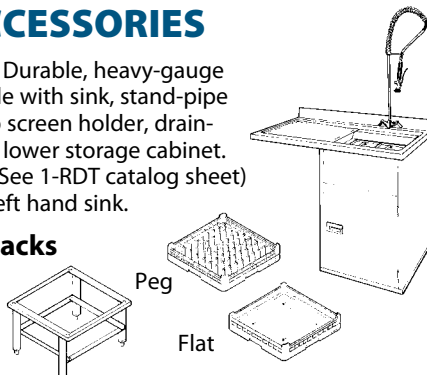

# UH230B

Undercounter High Temperature Dishwashing Machine with Built-in Booster Heater

# Champion®

The Dishwashing Machine Specialists

Volume crated: **15 cu. ft./0.42 cu.m.**  
 Shipping weight crated: **215 lbs./97.5 kg.**

Dimensions shown in inches and [millimeters]

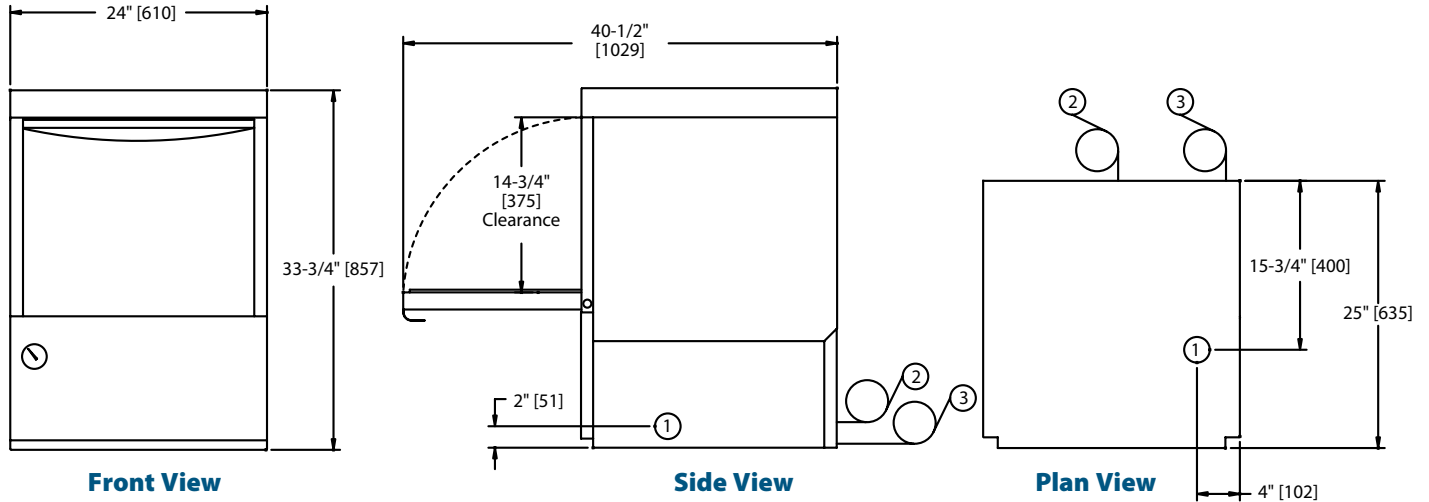

Utilities	
<b>1 Electrical</b>	208-240/60/1; 3 wire plus ground, (See Box). 208-240/60/3; 4 wire plus ground, (See Box). Field convertible to accept 3 phase power, see service manual for details
<b>2 Hot Water</b>	1/2" supply; 140°F/60°C Min. hot water connection for 40°F/22°C rise booster; 110°F/43°C Min. hot water connection for 70°F/39°C rise booster. Incoming supply pressure must maintain a Flow pressure of 20-22 PSI. If machine is sold without internal booster, a 1/2" PRV is required to be purchased. Machine equipped with 3/4" [19] hose connector.
<b>3 Pumped Drain</b>	5/8" [15.9] I.D. flexible reinforced hose, 6 ft. [1829] long. Max. drain flow 15 US gpm. [12.5 imp gal] Max. drain height 3 ft. [914]

## SPECIFICATIONS

<b>Capacities</b>	
Cycle time (seconds)	90
Racks per hr.	40
<b>Motor horsepower</b>	
Wash	1
<b>Water consumption</b>	
U.S. Gal./Imperial Gal. (Max. use) per hr.	23.4/19.2
U.S. Gal./Imperial Gal. per rack	0.78/0.64
<b>Temperatures °F/°C</b>	
Wash	150/66
Rinse	180/82
<b>Heating</b>	
Tank heat, electric, kW	2.0
Electric booster (kW) required for 40°F/22°C rise	6
Electric booster (kW) required for 70°F/39°C rise	9
<b>Time Cycle in Seconds</b>	
Wash	70
Rinse	14
Total cycle	90
<b>Standard 20" x 20" [508 x 508] Rack Complement</b>	
Dish	1
Open	1

UH230B with 40°F/22°C Rise Booster				UH230B with 70°F/39°C Rise Booster			
Elec. Specs.	Rated Amps	Minimum Supply Ckt. Conductor Ampacity	Maximum Overcurrent Protective Device	Elec. Specs.	Rated Amps	Minimum Supply Ckt. Conductor Ampacity	Maximum Overcurrent Protective Device
208/60/1	32	40	40	208/60/1	45	60	60
240/60/1	36	40	40	240/60/1	50	60	60
208/60/3	22	30	30	208/60/3	29	35	35
240/60/3	24	30	30	240/60/3	33	40	40

Field convertible to accept 3 phase power

**Warning** Plumbing and electrical connections should be made by qualified personnel who will observe all the applicable plumbing, sanitary and safety codes and the National Electrical Code.

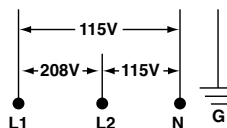

**Note:** Electrical supply service must be a 3-wire plus ground for connection shown.

UH230 without booster 750 Watt tank heat	
Elec. Specs.	Rated Amps
115/60/1	12

Due to an ongoing value analysis program at Champion, specification contained in this catalog are subject to change without notice.

Champion Industries, Inc., 3765 Champion Blvd, Winston-Salem, NC 27105 • 336/661-1556 • Fax: 336/661-1979 • www.championindustries.com  
 2674 N. Service Road, Jordan Station, Ontario, Canada L0R 1S0 • 800/263-5798 • Fax: 905/562-4618