



110 Woodcrest Road, Cherry Hill, NJ 08003-3648
 856.428.4200 • 800.523.5008 • Fax: 856.428.7299
 www.victoryrefrigeration.com • email: sales@victoryrefrigeration.com



PROJECT: _____
 LOCATION: _____
 ITEM #: _____
 QUANTITY: _____

SOLID DOOR TOP MOUNT REACH-IN FREEZERS

V-SERIES™

STANDARD FEATURES

- New V-SERIES™ Electronic Control with SUPERCOOL Mode
- High Performance, Balanced, Top-Mounted Refrigeration
- Unique Magnetic Proximity Door Switch Activates Lighting
- Anti Corrosion Coated Evaporator Coil
- Stainless Steel Front and Wrap Around Sides
- Aluminum Interior and Floor
- Environmentally Safe R-404A Refrigerant
- 2.5" Min. Foamed-in-Place Polyurethane Insulation
- Self-Closing Doors with 120° Hold Open Feature
- One Piece, Snap-In Magnetic Door Gasket(s)
- Door Lock(s) Standard
- Sleek, Ergonomic, Easy Grip Horizontal Door Handle(s)
- Three (3) Epoxy Coated Wire Shelves per Section
- Accommodates 18" X 26" or 12" X 20" pans
- 6" Overall Height Casters (Set of 4)
- Cam-Lift Hinges
- Recessed Interior Incandescent Lighting
- 10' Cord and Plug (See Electrical Data for Details)

OPTIONS AND ACCESSORIES

- Change Door Swing
- Expansion Valve Technology
- Fluorescent Lighting (Standard on Glass Door Models)
- LED Lighting
- Stainless Steel Finished Back
- 6" Legs in Lieu of Casters
- 4" Overall Height Casters (Set of 4)
- Kit with Universal Pan Slides
- Kit with Rod Type Pan Slides
- Kit with Angle Type Pan Slides
- 220/50 Hz, 220/60 Hz Voltages
- Remote Models (Standard with Legs)
- Extended Warranty
- Extra Shelves



VF-SA-1D

MODELS		
	FULL-DOOR	HALF-DOOR
SOLID DOOR	VF-SA-1D*	VF-SA-1D-HD
	VF-SA-2D*	VF-SA-2D-HD
	VF-SA-3D	VF-SA-3D-HD



* Noted models are ENERGY STAR® listed. Please refer to www.energystar.gov to view the most up-to-date product listing and performance data.

1 Year Parts And Labor
5 Year Compressor Part Warranty

Victory Refrigeration specification sheets are available online at www.victoryrefrigeration.com

APPROVALS:

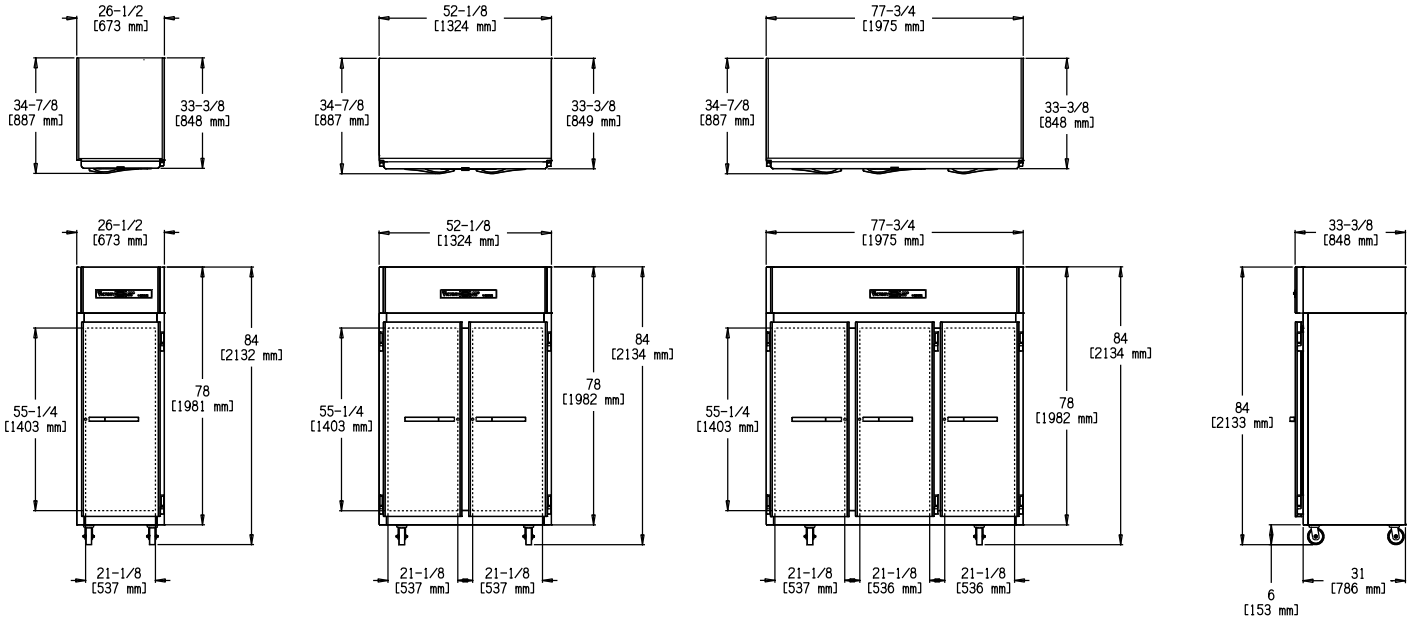

We reserve the right to change specifications and product design without notice. Such revisions do not entitle the buyer to corresponding changes, improvements, additions or replacements for previously purchased equipment.

Dimensional tolerances +/- 1/4". Metric dimensions (MM)

V-SERIES™ CABINET CONSTRUCTION

The cabinet front, doors, grills and sides are constructed of polished stainless steel with the inside walls and bottom in aluminum. There is a minimum of 2.5" polyurethane foam insulation throughout (3.5" on the bottom) to ensure energy efficiency. The front grill is removable (snap-on / snap-off, no tools required) allowing easy access for cleaning the condenser. Standard lighting is recessed incandescent on solid door models.

V-SERIES™ DOOR CONSTRUCTION

The solid doors are constructed with a heavy gauge, polished stainless steel exterior and a durable ABS plastic liner. Each solid door is provided with a lock and an ergonomically correct handle. A unique magnetic proximity door switch controls the lighting on the solid door models. Cam-lift door hinges are self-closing and have a hold-open feature at 120°. Snap in place, one piece magnetic gasket(s). One section cabinets feature field reversible doors. Two and three section cabinets can have their door swing reversed at the time of order (right hinging standard).

V-SERIES™ REFRIGERATION SYSTEM

All components of the high efficiency, air-cooled, self-contained refrigeration system are mounted on top of the cabinet out of the food storage zone thereby providing greater useable storage space. Environmentally friendly R-404A freezers are metered by a capillary tube system providing a constant, safe operating temperature and quick recovery under most conditions. The temperature range on the V-SERIES™ Electronic Control is -6°F to 15°F for freezers. Each cooling coil has an anti-corrosion coating and all units feature an energy efficient hot gas condensate evaporation system.

V-SERIES™ INTERIOR STORAGE ARRANGEMENTS

Each cabinet section is provided with three (3) heavy-duty, epoxy coated shelves. The shelves are adjustable in one inch increments. A wide door opening allows for the use of a variety of optional pan slide configurations (18" x 26" and 12" x 20").

V-SERIES™ ELECTRONIC CONTROL SYSTEM

The easy to use V-SERIES™ Control is state of the art with many exclusive features including **SUPERCOOL Mode**, **Energy Saving Mode**, multiple audible and visual alarms (minimum temperature, maximum temperature, door ajar, probe failure, clean condenser and compressor protection). Maintains three most recent alarms in memory. **SUPERCOOL Mode** runs the compressor constantly for a pre-determined amount of time or until a lower set-point has been reached. **Energy Saving Mode** activates automatically when there are no door openings for a pre-determined period of time.

CHARACTERISTICS

	1 SECTION	2 SECTION	3 SECTION
DIMENSIONAL DATA			
Width, Overall (in.)	26 1/2	52 1/8	77 3/4
Depth, Overall (inc. Handles)	34 7/8	34 7/8	34 7/8
Height Overall (inc. 5" Casters)	84	84	84
Depth, Door(s) Open 90° (in.)	56 3/4	56 3/4	56 3/4
Clear Door Opening, Width (in.)	21 1/8	21 1/8	21 1/8
Clear Full-Door Opening, Height (in.)	55 1/4	55 1/4	55 1/4
Clear Half-Door Opening, Height (in.)	25 3/8	25 3/8	25 3/8
Capacity Net (cu. ft.)	21.5	46.5	70.1
No. of Full Doors	1	2	3
No. of Half Doors	2	4	6
No. of Shelves	3	6	9
Shelf Area (sq. ft.)	17.1	36.0	54.2

ELECTRICAL DATA

Cabinet Voltage	115/60/1	115/60/1	115/60/1
Feed Wires	2	2	3
Condensing Unit Voltage	115/60/1	115/60/1	208-230/60/1
NEMA Plug	5-15P	5-20P	NO
Total Amperes	8.5	12	12.9

REFRIGERATION DATA

BTUH (@ 90°F AMB and -10°F EVAP)	1960	2880	3790
Condensing Unit Size (HP)	1/3 HP	1/2 HP	3/4 HP
Refrigerant	R-404a	R-404a	R-404a

NOTE: Plug style, voltage and full load amps may vary depending on certain options selected such as special voltages and compressor upgrades.

REMOTE APPLICATIONS: See form V-RRDS1 for remote refrigeration characteristics by model.

CRATED DIMENSIONS & WTS.	HT.	WIDTH	DEPTH	FT ³	LBS
ONE SECTION	84 1/2	36	43	75.70	325
TWO SECTION	84 1/2	59 1/4	43	124.59	530
THREE SECTION	84 1/2	86 1/2	43	181.89	650

NOTE: In order to provide peak operating performance the cabinet must have a 2 inch all around clearance and 12 inches above the top of the condensing unit. This ensures an adequate air supply and space for routine maintenance and/or service if required.

When ordering please specify: Voltage, Hinging, Door Size, Options and Any Extended Warranty.