



STAR-MAX® VERTICAL BROILERS

MODELS VBE30 & VBG30

FEATURES/BENEFITS

- Star-Max® Vertical Broilers feature a full rotisserie rod for maximum control of broiling speeds and accommodate a variety of meat products and sizes.
- Available in either electric or gas - natural or LP options. (Not field convertible.)
- Fully adjustable range of temperature for precise cooking performance. (Gas Only)
- 5 - 45 lb meat capacity.
- Simple disassembly for easy clean-up.
- Adjustable heat shields concentrate heat for cooking and direct heat away from the operator to allow for faster cooking and reduced energy costs.
- The automatic friction drive stops rotation during slicing allowing for quick and easy carving.
- Made in the U.S.A.

Application:

Star-Max® Vertical Broilers are designed for display cooking and built for fast food and Mediterranean style restaurants. Our broilers provide high performance broiling for a crisp, juicy and flavorful taste and are perfect for today's diverse menu selections.

Quality Construction:

Star-Max® Vertical Broilers are constructed of stainless steel front and sides. Back, bottom, rotisserie rod and pans are constructed of aluminized steel. Electric models operate on 208 or 240V. Gas units require 120V connection. Adjustable valves and standing pilot are standard (gas unit). Electric model features incoloy sheath type heating elements. Gas unit features infrared ceramic heating elements and is not convertible in the field.

Warranty:

Star-Max® Vertical Broilers are covered by a **one year** parts and labor warranty.



VBE30



VBG30

STAR-MAX® VERTICAL BROILERS





STAR-MAX® VERTICAL BROILERS

MODELS VBE30 & VBG30

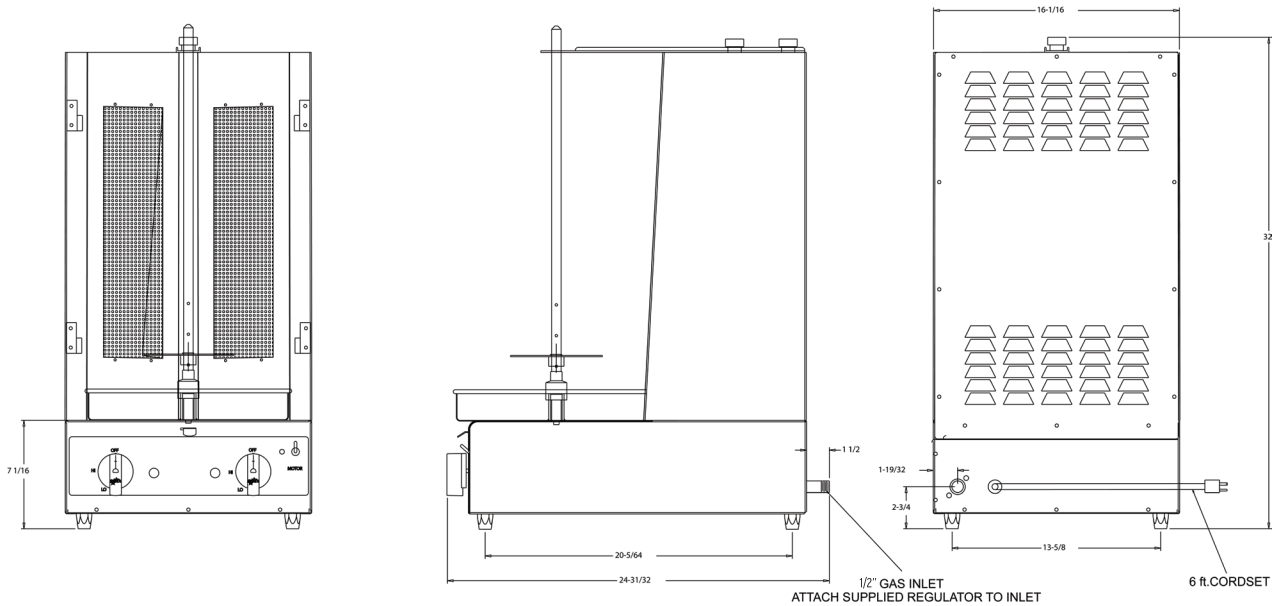

GAS MODEL SHOWN- ELECTRIC MODEL IS SIMILAR SIZE WITH A DIFFERENT CORDSET, HEATING ELEMENTS AND CONTROL PANEL. READ OWNERS MANUAL FOR PROPER INSTALLATION. THIS APPLIANCE SHOULD BE USED WITH ADEQUATE VENTILATION UNDER A HOOD.

Specifications

Model No.	Dimensions			Volts	Gas Type	BTU	KW	Amps	Plug	Ship (lbs)	Installed (lbs)
	Width (cm)	Depth (cm)	Height (cm)								
VBE30	40.79 (16.06)	63.42 (29.97)	81.28 (32)	208V 240V			4.5	21.6 18.8	NEMA 6-30P	70.1	60.0
VBG30	40.79 (16.06)	63.42 (29.97)	81.28 (32)	120V	NAT LP	30,000		0.4	NEMA 5-15P	70.1	60.0

NOTE: Maintain clearance of 3" from back and 12" from side for combustible construction. May be 0" for non-combustible construction. Cooking weight capacity of 45lbs. Gas unit is not convertible in the field. ETL listed for both USA and Canada

Typical Specifications

Star-Max® Vertical Broilers are constructed of stainless steel front and sides. Back, bottom, rotisserie rod and pans are constructed of aluminizes steel. Electric models operate on 208 or 240V. Gas units require 120V connection. Adjustable valves and standing pilot are standard (gas unit). Gas unit features tubular ceramic heating elements and electric model features incoloy sheath type heating elements. Broilers have a 5-45 lb. meat capacity with a fully adjustable range of temperature. Star-Max® Vertical Broilers are ETL Sanitation listed. Printed in the U.S.A.

Due to periodic changes in designs, methods, procedures, policies and regulations, the specifications contained in this sheet are subject to change without notice. While Star Manufacturing exercises good faith efforts to provide information that is accurate, we are not responsible for errors or omissions in information provided or conclusions reached as a result of using the specifications. By using the information provided, the user assumes all risks in connection with such use.

Star Manufacturing International Inc. - 10 Sunnen Drive - P.O. Box 430129 - St. Louis, MO 63143-3800

Phone: (800) 264-7827 - Fax: (800) 264-6666 - www.Star-Mfg.com