



Project:

Item Number:

Quantity:

## CAYENNE® MEDIUM-DUTY CHARBROILERS



40730

Cayenne® Charbroiler

### DESCRIPTION

Vollrath's Cayenne® charbroilers are built solid. Versatile grill plates feature narrower grill surfaces on one side, with integral channels specially designed to dispense excess fat, reducing smoke and flames. The flip side features flatter, wider grill surfaces, ideal for fish and other more delicate items. Angled adaptor bars enable the grill plates to be angled away from heat for slower cooking. This directs grease away to minimize flare-ups.

### CLEARANCE AND POSITIONING

This appliance must be installed with a minimum clearance of 6" (15.2 cm) between the left, right and back sides, and any combustible surface. The supplied 4" (10.2 cm) legs must be installed and the unit placed on a non-combustible surface.

### MODELS

- 40728 CBL9012 12" Radiant/Lava Rock Charbroiler
- 40729 CBL9016 18" Radiant/Lava Rock Charbroiler
- 40730 CBL9024 24" Radiant/Lava Rock Charbroiler
- 40731 CBL9036 36" Radiant/Lava Rock Charbroiler
- 40837 CBL9048 48" Radiant/Lava Rock Charbroiler
- 40838 CBL9060 60" Radiant/Lava Rock Charbroiler

### FEATURES

- Ships complete with kits for both radiant and lava rock set up
- Shipped set up for natural gas — includes kit with regulator for field conversion to propane
- Stainless and aluminized steel, fully-welded construction to eliminate grease and dirt traps
- Superior stainless steel burner design allows for better heat distribution and faster recovery
- Burners placed every 12" for optimum heat distribution. 18" unit has one burner.
- Heavy-duty gas valves ensure long life
- Heavy-duty adjustable legs
- Cool-to-touch bull-nose design protects from burns
- 12" unit (40758) offers smallest footprint for when space is an issue
- All metal knobs and knob guards protect gas valves from damage and won't break or crack and are **GUARANTEED FOR LIFE**
- ¾" NPT gas inlet

**WARRANTY:** All models shown come with Vollrath's standard warranty against defects in materials and workmanship. For full warranty details, please refer to the Vollrath Equipment and Smallwares Catalog.

### Agency Listings



Due to continued product improvement, please consult [www.vollrathco.com](http://www.vollrathco.com) for current product specifications.

Approvals	Date



[www.vollrathco.com](http://www.vollrathco.com)

The Vollrath Company, L.L.C.  
1236 North 18th Street  
Sheboygan, WI 53081-3201 U.S.A.  
Customer Service: 800.628.0830  
Canada Customer Service: 800.695.8560  
Main Fax: 800.752.5620 or 920.459.6573

Technical Services: 800.628.0832  
Technical Services Fax: 920.459.5462

Cayenne® Medium-Duty Charbroilers

The Vollrath Company, L.L.C.

## CAYENNE® MEDIUM-DUTY CHARBROILERS

MODELS	40728 CBL9012 12" Radiant/Lava Rock Charbroiler	40731 CBL9036 36" Radiant/Lava Rock Charbroiler
	40729 CBL9016 18" Radiant/Lava Rock Charbroiler	40837 CBL9048 48" Radiant/Lava Rock Charbroiler
	40730 CBL9024 24" Radiant/Lava Rock Charbroiler	40838 CBL9060 60" Radiant/Lava Rock Charbroiler

### DIMENSIONS

Dimensions shown in inches (cm).

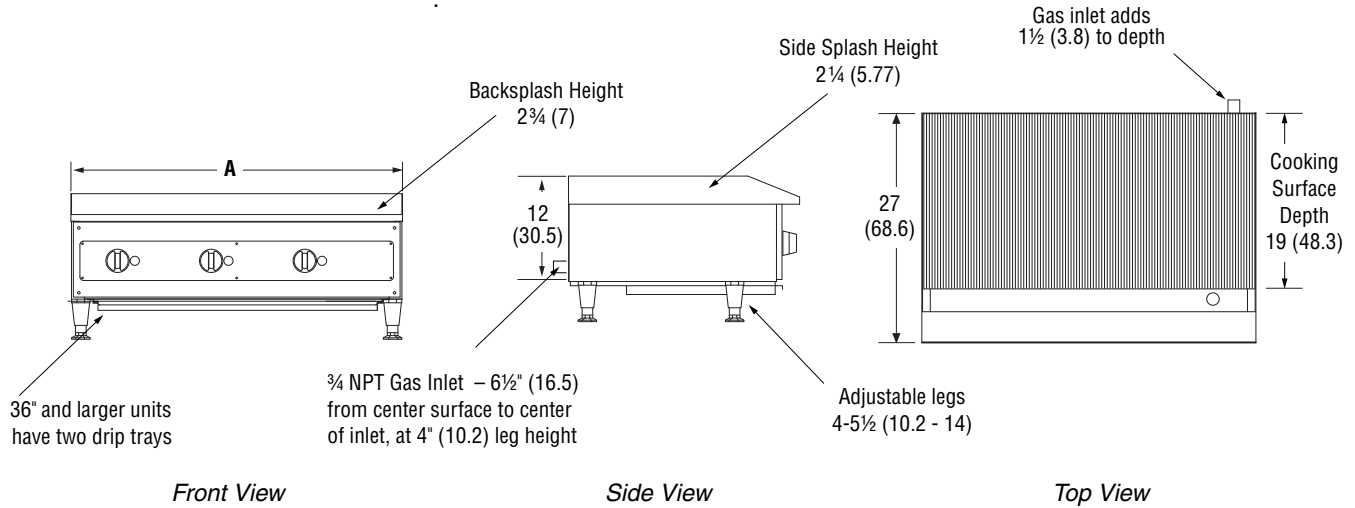

### SPECIFICATIONS

Item	(A) Width	Output (BTU)	Number of Burners	Control Type	Pilot Type	Number of Drip Trays	Ship Weight Lb (Kg)
40728	12 (30.5)	28000	1	Manual	Standing	1	95 (43.1)
40729	18 (45.7)	28000	1	Manual	Standing	1	120 (54.4)
40730	24 (61.0)	56000	2	Manual	Standing	1	160 (72.6)
40731	36 (91.4)	84000	3	Manual	Standing	1	226 (102.5)
40837	48 (121.9)	112000	4	Manual	Standing	2	392 (177.8)
40838	60 (152.4)	140000	5	Manual	Standing	2	470 (213.2)



www.vollrathco.com

The Vollrath Company, L.L.C.  
 1236 North 18th Street  
 Sheboygan, WI 53081-3201 U.S.A.  
 Customer Service: 800.628.0830  
 Canada Customer Service: 800.695.8560  
 Main Fax: 800.752.5620 or 920.459.6573

Technical Services: 800.628.0832  
 Technical Services Fax: 920.459.5462