



Project:

Item Number:

Quantity:

HEAVY-DUTY SLICERS



40849 / 40797



40799



40801



40800

Heavy-Duty Slicers

DESCRIPTION

Vollrath's five heavy-duty slicers, all with 12" (30.5 cm) blades and a non-stick coating, are designed to meet the challenges of any high-use operation.

STANDARD FEATURES

- Exclusive non-stick coating – great for cutting cheese
- Vollrath's rock solid guides will not flex, giving straight slices every time
- Heavy-weight meat pusher pushes meat into blade more effectively for easier cuts and less user fatigue
- One-piece, hard-coated anodized aluminum body eliminates food traps and provides light weight with high durability
- Precision spacing cam for more accurate thickness cutting
- Low-friction carriage system provides outstanding smooth glide motion
- Sand-molded, anodized base will never tarnish
- Built-in easy to use two stone sharpener makes blade sharpening simple and convenient
- Thermal overload protection with manual reset automatically shuts off slicer to protect from damage
- Easy-tilt product feeder mechanism makes it easy to clean safely without the product feeder dropping
- 5 ft. (1.5 m) cord with plug

MODELS

- 40849 SLR7012/N Belt Driven
- 40797 SLR 7712/N Belt Driven with Safe Blade Removal System
- 40799 SLR7512/N Gear-Driven
- 40801 SLM0012/N Belt Driven with Maximum Clearance Receiving Tray and Safe Blade Removal
- 40800 SLR7912/N Automatic Slicer with Safe Blade Removal

FEATURES

Belt Driven

- Heavy-duty slice adjustment for precise and consistent slice thickness
- Centered blade and gauge plate ensure stability under the toughest conditions

Gear Driven

- Direct drive gear transmission provides the power and robustness for high-volume slicing of cheese and meat

Maximum Clearance Receiving Tray

- Special clear slice exit design provides unobstructed receiving tray area for easier slicing and cleaning
- Extended 1 1/4" (3.175 cm) maximum slice thickness for greater versatility

Automatic Carriage

- Automatic carriage slices approximately 40 slices per minute for maximum operational efficiency
- Intuitive setup includes simple main switch and variable speed control
- Can also be used manually

MODEL COMPARISON

Feature	40849	40797	40799	40801	40800
Non-Stick Coating	X	X	X	X	X
Accommodates Vegetable Chute	X	X	X	X	X
Automates Frozen Food Blade	X	X	X	X	X
Safe Blade Removal System		X		X	X
Gear Drive			X		
Belt Drive	X	X		X	X
Kickstand					X
Max Clearance Receiving Tray				X	
Automatic Cartridge					X

WARRANTY: All models shown come with Vollrath's standard warranty against defects in materials and workmanship. For full warranty details, please refer to the Vollrath Equipment and Smallwares Catalog.

Agency Listings



Due to continued product improvement, please consult www.vollrathco.com for current product specifications.

Approvals	Date



Setting the Standard™

www.vollrathco.com

The Vollrath Company, L.L.C.
 1236 North 18th Street
 Sheboygan, WI 53081-3201 U.S.A.
 Customer Service: 800.628.0830
 Canada Customer Service: 800.695.8560
 Main Fax: 800.752.5620 or 920.459.6573

Technical Services: 800.628.0832
 Technical Services Fax: 920.459.5462

HEAVY-DUTY SLICERS

MODELS

40849 SLR7012/N Belt Driven
 40797 SLR 7712/N Belt Driven with Safe Blade Removal System
 40799 SLR7512/N Gear-Driven

40801 SLM0012/N Belt Driven with Maximum Clearance Receiving Tray and Safe Blade Removal
 40800 SLR7912/N Automatic Slicer with Safe Blade Removal

DIMENSIONS

Dimensions shown in inches (cm).

40849 / 40797

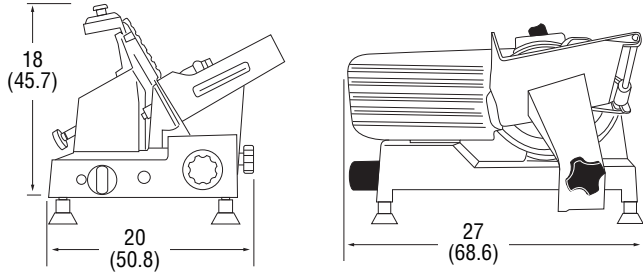

Front View

Side View

40799

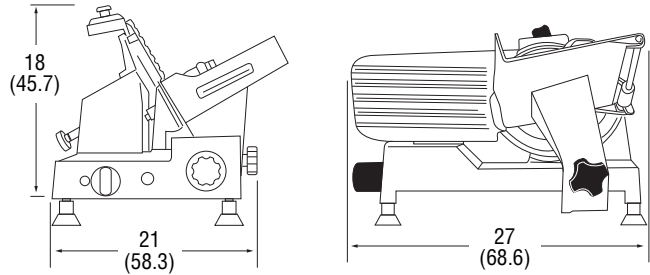

Front View

Side View

40801

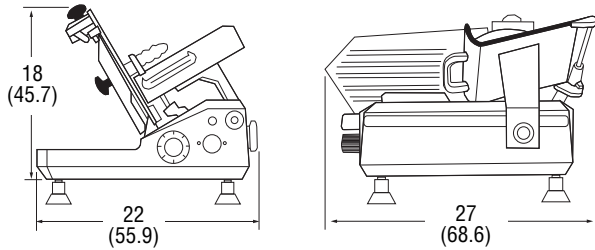

Front View

Side View

40800

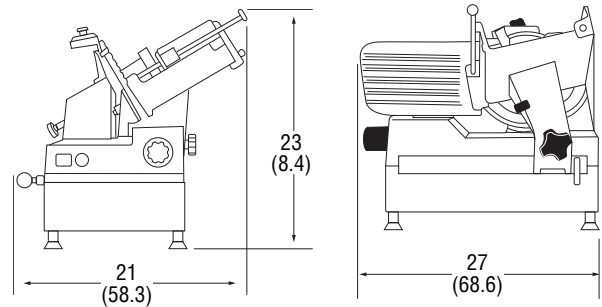

Front View

Side View

SPECIFICATIONS

Item	Drive	Slicing Capacity		HP	Voltage	Amps	Plug
		Processed Meats	Cheese				
40849	Belt	3 hr/day	1 hr /day or less	½	110	2.5	5-15P
40797	Belt	3 hr/day	1 hr /day or less	½	110	2.5	5-15P
40799	Gear	Continuous	Continuous	½	110	2.5	5-15P
40801	Belt	Continuous	3 hr/day	⅔	110	2.5	5-15P
40800	Belt	Continuous	Continuous	¾	110	4.7	5-15P

Receptacle

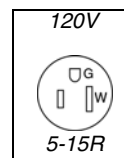

www.vollrathco.com

The Vollrath Company, L.L.C.
 1236 North 18th Street
 Sheboygan, WI 53081-3201 U.S.A.
 Customer Service: 800.628.0830
 Canada Customer Service: 800.695.8560
 Main Fax: 800.752.5620 or 920.459.6573

Technical Services: 800.628.0832
 Technical Services Fax: 920.459.5462