



Commercial Countertop Deep Fryer

WDF75RC / WDF75B

Features

- 8.5 lb electric deep fryer
- Twin steel wire baskets – 3 lb food capacity
- Hinged heating element and removable stainless steel tank
- 30-minute timer
- Available in 120V and 208V
- UL, NSF approved
- Limited One-Year Warranty



Optional 3 lb.
Single Basket Available
#LFB75





Commercial Countertop Deep Fryer WDF75RC / WDF75B



Specifications

Item	Electrical	Listings	Dimensions (H" x W" x D")	Warranty
WDF75RC	120 V, 1800 W	UL, NSF	11" x 16.5" x 12.25"	Limited 1 Year
WDF75B	208 V, 2700 W	UL, NSF	11" x 16.5" x 12.25"	Limited 1 Year

Ordering Information

Description	Catalog #	Std Pkg.	Ship Wt. (lbs.)	Cubic Feet	UPC Code
Countertop Deep Fryer	WDF75RC	1	13.0	3.9	040072005947
Countertop Deep Fryer	WDF75B	1	13.0	3.9	040072005954
Large 3 lb. Basket	LFB75	1	1.9	.95	040072009907

WDF75 Series

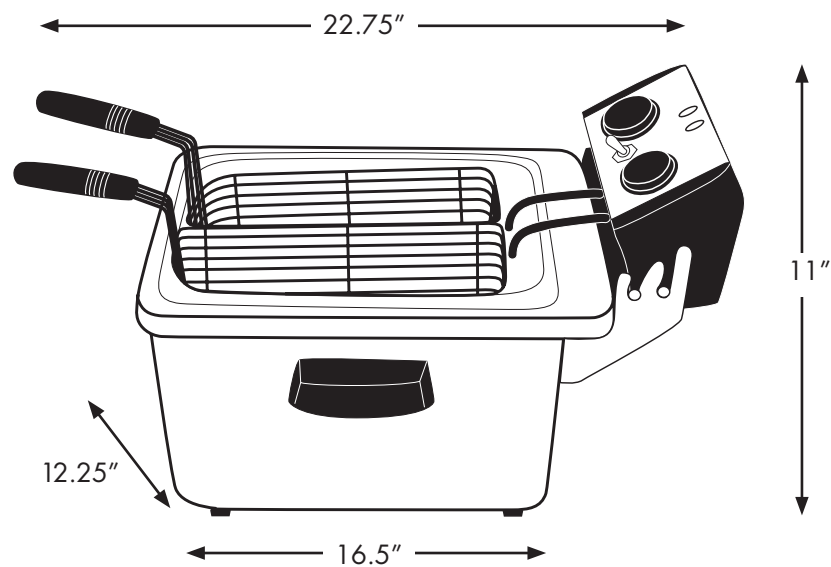

Waring Commercial • 314 Ella T. Grasso Ave. • Torrington • Connecticut 06790
Tel. (800) 492-7464 • Fax (860) 496-9008 • www.waringproducts.com • ©2007

07WC30100
PG-21497