

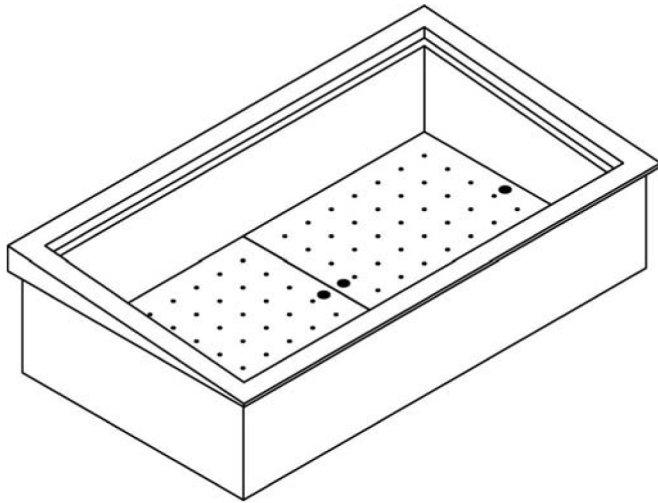

Ice Pans With Slope Top Non-Refrigerated Cold Pans

- ICP-100ST
- ICP-200ST
- ICP-300ST
- ICP-400ST
- ICP-500ST
- ICP-600ST



Model ICP-300ST

DESCRIPTION

Wells Non-Refrigerated Drop-In Ice Pans with slope tops are designed to hold pre-chilled food products at serving temperatures. All models are completely self-contained in one to six-well models featuring CFC free insulation. Recessed top ledges lowers inset pans; keeping food colder and fresher and meet NSF-2 guidelines. The sloped top provide customers with improved visibility and access to food products.

SPECIFICATIONS

Exterior – One-piece top flange and coved-corner interiors constructed of 18 gauge stainless steel. Exterior body constructed of heavy gauge, corrosion resistant steel.

Interior – CFC free foamed-in-place insulation through-out. Each pan features a 1" drain located in the center for easy cleaning, and recessed ledges for pan support.

STANDARD FEATURES

- Drop-in design
- NSF-2 compliant
- Pans are raised in the rear for improved visibility and access to food products
- Hold standard 12" by 20" food pans and fractional sized pans
- 18 gauge stainless steel top and liner for maximum strength and durability
- 1" drains per well for ease of cleaning
- Perforated bottom strainer plate conveniently holds ice above drain for ease of cleaning
- CFC free fully insulated
- Foamed-in place insulation keeps food cold while saving energy
- Recessed ledge for pan support and colder, fresher products
- Limited 1 year parts and labor warranty

OPTIONS & ACCESSORIES

- Divider bars for fractional pans
- 2nd year parts & labor warranty

CERTIFICATIONS





Over 90 Years Of Quality Foodservice
Products And Service

Ice Pans With Slope Top Non-Refrigerated Cold Pans

- ☐ ICP-100ST ☐ ICP-200ST ☐ ICP-300ST
- ☐ ICP-400ST ☐ ICP-500ST ☐ ICP-600ST

INCHES
MM

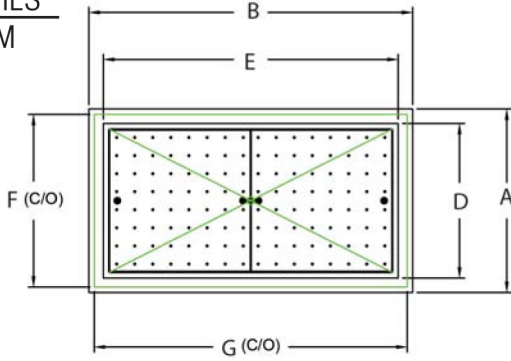

PLAN VIEW

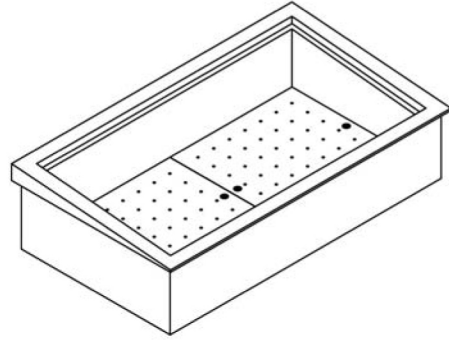

ISOMETRIC VIEW

ICP-300ST SHOWN

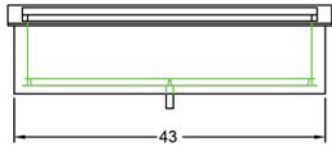

FRONT ELEVATION

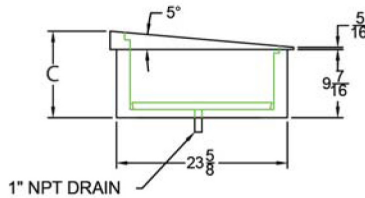

SIDE ELEVATION

NOTE: Specifications are subject to change without notice and are not intended for installation purposes. See installation instructions prior to installing the unit.

SPECIFICATIONS

Model Number	OVERALL DIMENSIONS			INTERIOR DIMENSIONS		CUT OUT DIMENSIONS	
	A Front to Back Inches (MM)	B Left to Right Inches (MM)	C Height Inches (MM)	D Front to Back Inches (MM)	E Left to Right Inches (MM)	F Front to Back Inches (MM)	G Left to Right Inches (MM)
ICP-100ST	25-3/8 (645)	17-3/8 (441)	12 (303)	19-7/8 (505)	11-7/8 (301)	23-7/8 (606)	15-7/8 (403)
ICP-200ST	25-3/8 (645)	31 (787)	12 (303)	19-7/8 (505)	25-1/2 (648)	23-7/8 (606)	29-1/2 (749)
ICP-300ST	25-3/8 (645)	44-3/4 (1137)	12 (303)	19-7/8 (505)	39-1/4 (997)	23-7/8 (606)	43-1/4 (1099)
ICP-400ST	25-3/8 (645)	58-1/2 (1486)	12 (303)	19-7/8 (505)	53 (1346)	23-7/8 (606)	57 (1448)
ICP-500ST	25-3/8 (645)	72-1/4 (1847)	12 (303)	19-7/8 (505)	66-3/4 (1695)	23-7/8 (606)	70-3/4 (1797)
ICP-600ST	25-3/8 (645)	86 (2184)	12 (303)	19-7/8 (505)	80-1/2 (2045)	23-7/8 (606)	84-1/2 (2146)

SHIPPING INFORMATION

Model Number	WEIGHTS		CARTON DIMENSIONS			CRATE SIZE	
	SHIPPING WEIGHT POUNDS (KG)	INSTALLED WEIGHT POUNDS (KG)	WIDTH Inches (MM)	DEPTH Inches (MM)	HEIGHT Inches (MM)	CUBIC FEET	CUBIC METERS
ICP-100ST	29.7 (13.5)	28.0 (12.7)	19 (482)	27 (686)	32 (813)	9.5	0.27
ICP-200ST	60.7 (27.5)	58.7 (26.6)	27 (686)	32 (813)	32 (813)	16.0	0.46
ICP-300ST	64.7 (29.4)	62.3 (28.3)	27 (686)	46 (1168)	32 (813)	23.0	0.65
ICP-400ST	86.0 (39.0)	83.3 (37.8)	27 (686)	60 (1524)	32 (813)	30.0	0.85
ICP-500ST	92.7 (42.1)	89.7 (40.7)	27 (686)	73 (1854)	32 (813)	36.5	1.04
ICP-600ST	96.7 (43.9)	93.3 (42.4)	27 (686)	87 (2210)	32 (813)	43.5	1.23

Due to periodic changes in designs, methods, procedures, policies and regulations, the specifications contained in this sheet are subject to change without notice. While Wells exercises good faith efforts to provide information that is accurate, we are not responsible for errors or omissions in information provided or conclusions reached as a result of using the specifications. By using the information provided, the user assumes all risks in connection with such use.



Wells Bloomfield • 10 Sunnen Dr. St. Louis, MO 63143 U.S.A.
Phone : (314) 678-6314 • Fax (314) 781-3636
www.wellsbloomfield.com

NOTE: Specifications are subject to change without notice and are not intended for installation purposes. See installation instructions prior to installing the unit.