

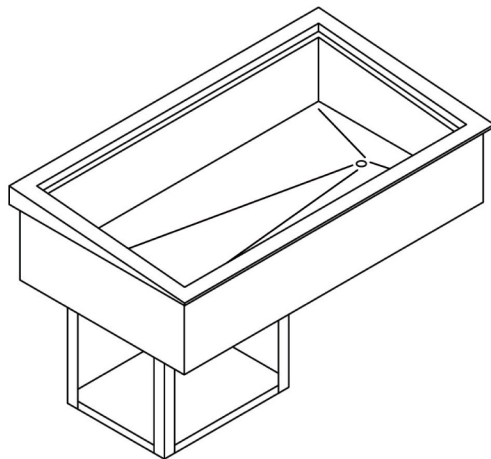

Refrigerated Cold Pans With Slope Top

- RCP-100ST RCP-200ST RCP-300ST
- RCP-400ST RCP-500ST RCP-600ST



Model RCP-300ST

DESCRIPTION

Wells Refrigerated Drop-In Cold Pans with sloped tops hold pre-chilled food products at cold, fresh and safe serving temperatures. All models are completely self-contained in one to six-pan models with individual thermostatic controls, are CFC free and include an 8 ft. 120V cord and plug. The sloped top provide customers with improved visibility and access to food products.

SPECIFICATIONS

Exterior – One-piece top flange and coved-corner interiors constructed of 18 gauge stainless steel. Exterior body constructed of heavy gauge, corrosion resistant steel. Condensing unit mounted on corrosion resistant frame below the cold pan.

Interior – CFC free foamed-in-place insulation through-out, 1" drain located in the center for easy cleaning, and recessed ledge for pan support.

Refrigeration – Type R134A and 404A, CFC free refrigerant system featuring wrapped coil construction on both sides and bottom, individual thermostats, on/off switch, 8 ft. cord and plug set NEMA 5-15P (120V models). Refrigeration system features sight glass, easy service valves, dryer/filter and receiver. Condensing unit may be easily removed for service.

STANDARD FEATURES

- Complies with NSF-2 Requirements
- Self contained drop-in design
- Hold standard 12" by 20" food pans and fractional sized pans
- Pans are raised in the rear for improved visibility and access to food products
- Stainless steel top and liner for maximum strength and durability
- 1" drains for ease of cleaning
- On-off switch with 8 ft. cord & plug for ease of installation and operation
- Type R134A and 404A CFC free refrigerant
- Fully insulated, CFC free, foamed-in place insulation keeps food cold while saving energy
- Recessed ledge for pan support and colder, fresher products
- Quick & easy service with sight glass, service valves, filter/dryer and receiver
- Limited 1 year parts and labor warranty

OPTIONS & ACCESSORIES

- 5-year compressor warranty
- Perforated bottom strainer plate
- Adaptor bars for fractional sized pans
- Remote on/off switch
- 220/230/240V
- 50 cycle
- Special condenser orientation and/or compressor rack position
- Remote models (Includes compressor and condensing units and up to 20' leads)
- Remote models without compressors or condensing units
- 2nd year parts & labor warranty

CERTIFICATIONS





Over 90 Years Of Quality Foodservice
Products And Service

Refrigerated Cold Pans With Slope Top

- ❑ RCP-100ST
- ❑ RCP-200ST
- ❑ RCP-300ST
- ❑ RCP-400ST
- ❑ RCP-500ST
- ❑ RCP-600ST

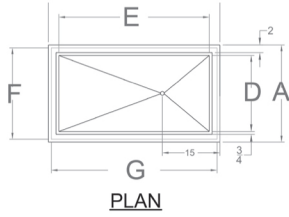

RCP-300ST SHOWN
COUNTER CUTOUT:
84 1/2" X 23 7/8"

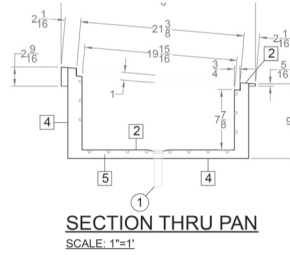

NOTE:
Specifications are subject to change without notice and are not intended for installation purposes. See installation instructions prior to installing the unit.

INCHES
MM

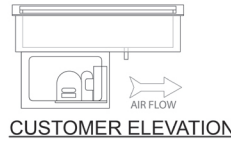
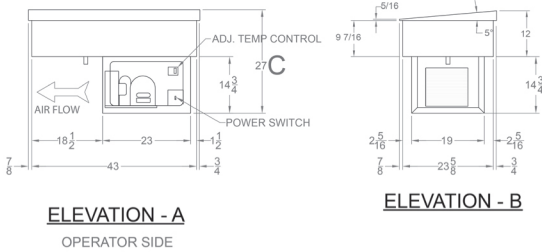

MATERIALS	
DESCRIPTION	QUANTITY
16 GA 304 SS	
18 GA 304 SS	
18 GA GALV	
20 GA GALV	
RIGID STYROFOAM INSULATION	



NOTE: CONTROLS LOCATED ON OPERATOR (HIGH) SIDE

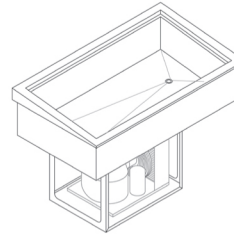

SPECIFICATIONS

SHIPPING INFORMATION

Model Number	OVERALL DIMENSIONS			INTERIOR DIMENSIONS		CUT OUT DIMENSIONS	
	A Front to Back Inches (MM)	B Left to Right Inches (MM)	C Height Inches (MM)	D Front to Back Inches (MM)	E Left to Right Inches (MM)	F Front to Back Inches (MM)	G Left to Right Inches (MM)
RCP-100ST	25-3/8 (645)	17-3/8 (441)	27 (686)	19-7/8 (505)	11-7/8 (302)	23-7/8 (606)	15-7/8 (454)
RCP-200ST	25-3/8 (645)	31 (787)	27 (686)	19-7/8 (505)	25-1/2 (648)	23-7/8 (606)	29-1/2 (749)
RCP-300ST	25-3/8 (645)	44-3/4 (1137)	27 (686)	19-7/8 (505)	39-1/4 (997)	23-7/8 (606)	43-1/4 (1099)
RCP-400ST	25-3/8 (645)	58-1/2 (1486)	27 (686)	19-7/8 (505)	53 (1346)	23-7/8 (606)	57 (1448)
RCP-500ST	25-3/8 (645)	72-1/4 (1835)	27 (686)	19-7/8 (505)	66-3/4 (1695)	23-7/8 (606)	70-3/4 (1796)
RCP-600ST	25-3/8 (645)	86 (2184)	27 (686)	19-7/8 (505)	80.5 (2045)	23-7/8 (606)	84-1/2 (2146)

Model Number	WEIGHTS		CARTON DIMENSIONS			CRATE SIZE	
	SHIPPING WEIGHT POUNDS (KG)	INSTALLED WEIGHT POUNDS (KG)	WIDTH Inches (MM)	DEPTH Inches (MM)	HEIGHT Inches (MM)	CUBIC FEET	CUBIC METERS
RCP-100ST	89 (40)	84 (38)	19 (482)	27 (686)	32 (813)	9.5	0.27
RCP-200ST	182 (83)	176 (80)	27 (686)	32 (813)	32 (813)	16.0	0.46
RCP-300ST	194 (88)	187 (85)	27 (686)	46 (1168)	32 (813)	23.0	0.65
RCP-400ST	258 (117)	250 (113)	27 (686)	60 (1524)	32 (813)	30.0	0.85
RCP-500ST	278 (126)	269 (122)	27 (686)	73 (1854)	32 (813)	36.5	1.04
RCP-600ST	290 (154)	280 (109)	27 (686)	87 (2210)	32 (813)	43.5	1.23

POWER SUPPLY

Model Number	VOLTS	HP	AMPS	PHASE	POWER SUPPLY	Refrigerant
RCP-100ST	115	1/4	5.5	SINGLE	NEMA 5-15P	134A
RCP-200ST	115	1/4	5.5	SINGLE	NEMA 5-15P	134A
RCP-300ST	115	1/4	5.5	SINGLE	NEMA 5-15P	134A
RCP-400ST	115	1/3	5.6	SINGLE	NEMA 5-15P	404A
RCP-500ST	115	1/2	6.4	SINGLE	NEMA 5-15P	404A
RCP-600ST	115	1/2	6.4	SINGLE	NEMA 5-15P	404A



Due to periodic changes in designs, methods, procedures, policies and regulations, the specifications contained in this sheet are subject to change without notice. While Wells exercises good faith efforts to provide information that is accurate, we are not responsible for errors or omissions in information provided or conclusions reached as a result of using the specifications. By using the information provided, the user assumes all risks in connection with such use.



Wells Bloomfield • 10 Sunnen Dr. St. Louis, MO 63143 U.S.A.
Phone : (314) 678-6314 • Fax (314) 781-3636
www.wellsbloomfield.com • Printed in the U.S.A.

NOTE: Specifications are subject to change without notice and are not intended for installation purposes. See installation instructions prior to installing the unit.