



BEVERAGE-AIR

3779 Champion Blvd., Winston-Salem, NC 27105
1-888-845-9800 Fax# 1-336-245-6453
<http://www.Beverage-Air.com>

Commercial Refrigeration Equipment General Specification

WTRD36 MODEL

Versatile, compact (29" depth) model for under the counter refrigerated storage of food products. Working height is 35 5/8".

CABINET CONSTRUCTION

Heavy duty construction includes exterior stainless steel on front, sides, drawers and grille. Stainless steel 2 1/2" thick worktop with 4" high removable backsplash. Cabinet back and bottom are galvanized steel. Interior liner is made of aluminum for longer lasting corrosion protection. Interior thermometer is standard.

Cabinet insulation is CFC and HCFC-free foamed-in-place polyurethane of two-inch minimum thickness. 6" high casters are standard, 2 include brakes. 6" legs and 3" casters are available as options.

DRAWER CONSTRUCTION

Drawer frames are constructed of heavy-duty stainless steel and are supported on heavy-duty telescoping drawer slides for maximum support of stored food products. Slides have locking mechanism to prevent from drawers being pulled off of cabinets. Upper pull-out drawers accommodate 6" deep pans. Lower pull-out drawers accommodate two 4" deep pans. Heavy-duty pan divider supports are supplied. Foodservice pans for drawers are not included. Snap-type vinyl magnetic gasket is attached to each drawer for positive seal. Drawers extend 15 3/4" (when opened).

REFRIGERATION

Refrigeration system utilizes R134a refrigerant governed by a capillary tube system. Automatic (non-electric) condensate evaporator is provided. Interior forced-air system with high humidity evaporator coils, provides the ideal environment for food preservation.

ELECTRICAL

Units wired at factory and ready for connection to a 115/60/1 phase, 15 amp dedicated outlet. 8' long cord and plug set included.

***Note:** Overall heights of casters may vary with different types of casters depending upon caster manufacturer designations.

Item No. _____
Quantity _____

WORK TOP REFRIGERATOR WITH DRAWERS WTRD36

MODELS:
WTRD36A



WTRD36A

SPECIAL FEATURES

- 6" casters, two with brakes standard.
- Optional 6" legs or 3" casters available

ELECTRICAL CONNECTION

Units pre-wired at factory and include 8' long cord and plug set.



115/60/1
NEMA-5-15P

Available From:



***Note:** Not all markings may apply to all model variations.

Model Specified _____	Store# _____
Location _____	Quantity _____



BEVERAGE-AIR

Standard Worktop Refrigerator Cabinet Models: WTRD36A

MODEL	WTRD36A
EXTERNAL DIMENSIONAL DATA	
Length Overall (inches)	36"
Length Overall (mm)	914
Depth Overall (inches) - Less handle	29 1/4"
Depth Overall (mm) - Less handle	743
Height Overall— on 6" casters (inches)*	39 1/2"
Height Overall—on 6" casters (mm)*	1003
Top Drawer Extension (when opened)	17 3/4"
Bottom Drawer Extension (when	15 3/4"
Number of Drawers	2
INTERNAL DIMENSIONAL DATA	
NET Capacity (cubic ft.)	8.5
NET Capacity (Liters)	241
Internal Length Overall (inches)	32"
Internal Length Overall (mm)	813
Internal Depth Overall (inches)	20"
Internal Depth Overall (mm)	508
Internal Height Overall (inches)	23"
Internal Height Overall (mm)	584
ELECTRICAL DATA	
Full Load Amperes 115/60/1	3.3
ENERGY CONSUMPTION (KWH)	
	N/A*
REFRIGERATION DATA	
Horsepower	1/5
WEIGHT DATA	
Gross Weight (Crated lbs)	210
Gross Weight (Crated kg)	95

***Note:** Overall heights of casters may vary with different types of casters depending upon caster manufacturer designations.



DRAWER SUPPORT CAPACITY

MODEL	# OF PAN SUPPORTS (SUPPLIED)	POSSIBLE PAN COMBINATION
WTRD36A	1 WIDE	(4) 1/3 SIZE PANS OR
	and	(1) FULL SIZE PAN + (1) 1/3 SIZE PAN OR
	2 NARROW	(8) 1/6 SIZE PANS

PLAN VIEWS

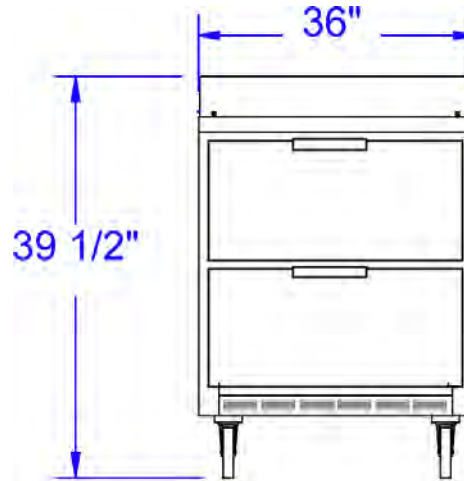

FRONT VIEW

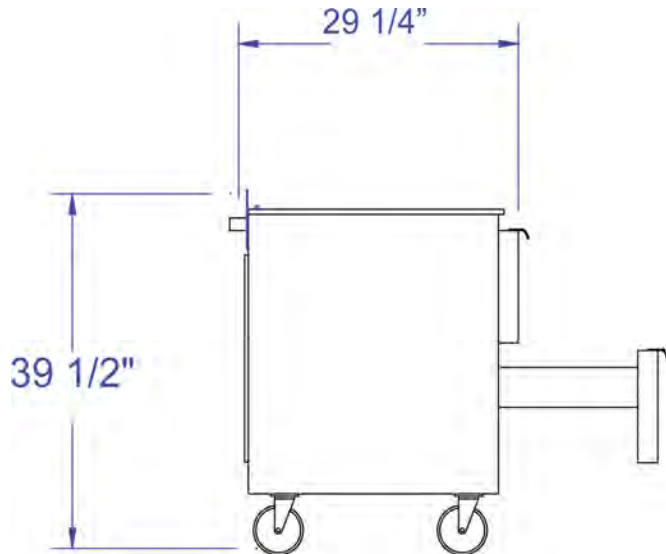

END VIEW

BEVERAGE-AIR® CORPORATION

3779 Champion Blvd. • Winston-Salem, NC 27105 USA • (336) 245-6400 • Fax (336) 245-6453 • (888) 845-9800 • www.beverage-air.com

Specifications are subject to change without prior notice. 09/12