



WELLS BLOOMFIELD, LLC
10 Sunnen Dr., St. Louis, MO 63143
telephone: 314-678-6314
fax: 314-781-2714
www.wellsbloomfield.com



Model WVF886RW

OWNERS MANUAL
WVF886 SERIES

**DUAL FRYPOT
AUTO-LIFT FRYER
with
UNIVERSAL HOOD**

**MODELS:
WVF886
WVF886RW
WVF886RWT**

**Includes
INSTALLATION
USE & CARE
EXPLODED VIEW
PARTS LIST
WIRING DIAGRAM**

IMPORTANT: DO NOT DISCARD THIS MANUAL

This manual is considered to be part of the appliance and is to be given to the OWNER or MANAGER of the restaurant, or to the person responsible for TRAINING OPERATORS of this appliance. Additional manuals are available from your WELLS DEALER.

THIS MANUAL MUST BE READ AND UNDERSTOOD BY ALL PERSONS USING OR INSTALLING THIS APPLIANCE. Contact your WELLS DEALER if you have any questions concerning installation, operation or maintenance of this equipment.

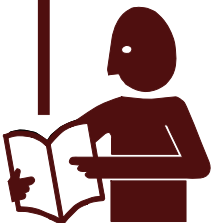

LIMITED WARRANTY STATEMENT

Unless otherwise specified, all commercial cooking equipment manufactured by WELLS BLOOMFIELD, LLC is warranted against defects in materials and workmanship for a period of one year from the date of original installation or 18 months from the date of shipment from our factory, whichever comes first, and is for the benefit of the original purchaser only.

THIS WARRANTY IS THE COMPLETE AND ONLY WARRANTY, EXPRESSED OR IMPLIED IN LAW OR IN FACT, INCLUDING BUT NOT LIMITED TO, WARRANTIES OF MERCHANTABILITY OR FITNESS FOR ANY PARTICULAR PURPOSE, AND/OR FOR DIRECT, INDIRECT OR CONSEQUENTIAL DAMAGES IN CONNECTION WITH WELLS BLOOMFIELD PRODUCTS. This warranty is void if it is determined that, upon inspection by an authorized service agency, the equipment has been modified, misused, misapplied, improperly installed, or damaged in transit or by fire, flood or act of God. It also does not apply if the serial nameplate has been removed, or if service is performed by unauthorized personnel.

The prices charged by Wells Bloomfield for its products are based upon the limitations in this warranty. Seller's obligation under this warranty is limited to the repair of defects without charge by a Wells Bloomfield factory authorized service agency or one of its sub-service agencies. This service will be provided on customer's premises for non-portable models. Portable models (a device with a cord and plug) must be taken or shipped to the closest authorized service agency, transportation charges prepaid, for service. In addition to restrictions contained in this warranty, specific limitations are shown in the Service Policy and Procedure Guide. Wells Bloomfield authorized service agencies are located in principal cities. This warranty is valid in the United States and Canada and void elsewhere. Please consult your classified telephone directory, your foodservice equipment dealer or contact:

Wells Bloomfield, LLC
10 Sunnen Dr., St. Louis MO 63143 USA
phone (314) 678-6314 or fax (314) 781-2714

for information and other details concerning warranty.

SERVICE POLICY AND PROCEDURE GUIDE and ADDITIONAL WARRANTY EXCLUSIONS

1. Resetting of safety thermostats, circuit breakers, over load protectors, and/or fuse replacements are **not** covered by this warranty unless warranted conditions are the cause.
2. All problems due to operation at **voltages or phase other than specified on equipment nameplates** are **not** covered by this warranty. Conversion to correct voltage and/or phase must be the customer's responsibility.
3. All problems due to **electrical connections not made in accordance with electrical code requirements and wiring diagrams** supplied with the equipment are **not** covered by this warranty.
4. Replacement of items **subject to normal wear**, to include such items as knobs, light bulbs; and, normal maintenance functions including adjustments of thermostats, adjustment of micro switches and replacement of fuses and indicating lights are **not** covered by warranty.
5. Damage to electrical cords and/or plug due to exposure to excessive heat are **not** covered by this warranty.
6. Full use, care, and maintenance instructions supplied with each machine. Noted maintenance and preventative maintenance items, such as servicing and cleaning schedules, are customer responsibility. Those miscellaneous adjustments noted are customer responsibility. Proper attention to preventative maintenance and scheduled maintenance procedures will prolong the life of the appliance.
7. Travel mileage is limited to **sixty (60) miles** from an Authorized Service Agency or one of its sub-service agencies.
8. All labor shall be performed during regular working hours. Overtime premium will be charged to the buyer.
9. All genuine Wells replacement parts are warranted for ninety (90) days from date of purchase on non-warranty equipment. This parts warranty is limited only to replacement of the defective part(s). **Any use of non-genuine Wells parts completely voids any warranty.**
10. Installation, labor, and job check-outs are **not** considered warranty and are thus **not** covered by this warranty.
11. Charges incurred by delays, waiting time or operating restrictions that hinder the service technician's ability to perform service are **not** covered by warranty. This includes institutional and correctional facilities.

SHIPPING DAMAGE CLAIM PROCEDURE

NOTE: For your protection, please note that equipment in this shipment was carefully inspected and packaged by skilled personnel before leaving the factory. Upon acceptance of this shipment, the transportation company assumes full responsibility for its safe delivery.

IF SHIPMENT ARRIVES DAMAGED:

1. **VISIBLE LOSS OR DAMAGE:** Be certain that any visible loss or damage is noted on the freight bill or express receipt, and that the note of loss or damage is signed by the delivery person.
2. **FILE CLAIM FOR DAMAGE IMMEDIATELY:** Regardless of the extent of the damage.

3. **CONCEALED LOSS OR DAMAGE:** if damage is unnoticed until the merchandise is unpacked, notify the transportation company or carrier immediately, and file "CONCEALED DAMAGE" claim with them. This should be done within fifteen (15) days from the date the delivery was made to you. Be sure to retain the container for inspection.

Wells Bloomfield cannot assume liability for damage or loss incurred in transit. We will, however, at your request, supply you with the necessary documents to support your claim.

TABLE OF CONTENTS

WARRANTY	xi
SPECIFICATIONS	1
FEATURES □ OPERATING CONTROLS	2
PRECAUTIONS □ GENERAL INFORMATION	6
AGENCY LISTING INFORMATION	7
INSTALLATION	8
OPERATION	13
CLEANING INSTRUCTIONS	17
DISPOSAL OF USED OIL	22
MAINTENANCE (Periodic Cleaning)	23
TROUBLESHOOTING SUGGESTIONS	24
MAINTENANCE SCHEDULES	26
MSDS (Ansulex Low pH)	29
ANSUL □ COMPONENTS	31
EXPLODED □ IEW □ PARTS LIST	32 □ 43
WIRING DIAGRAM	44 □ 46
PARTS □ SERVICE	49
CUSTOMER SERVICE DATA	49

INTRODUCTION

Thank You for purchasing this Wells Manufacturing Co. appliance.

Proper installation, professional operation and consistent maintenance of this appliance will ensure that it gives you the very best performance and a long, economical service life.

This manual contains the information needed to properly install this appliance, and to use and care for the appliance in a manner which will ensure its optimum performance.

SPECIFICATIONS

MODEL	ROLL WARMER	VOLTS 50/60 Hz	3Ø AMPS				1Ø AMPS	WATTS	DIMENSIONS POWER CORD	
			L1	L2	L3	N				
WVF886*	NO	208V	33	32	33	-	58	12,000	30-3/8" WIDE (42-3/8" wide including spacers) 77-3/16" HIGH, 35-3/8" DEEP, Power Cord (when provided):NEMA 15-60P	
		240V	29	28	29	-	50	12,000		
WVF886RW	YES	208V	37	32	37	-	61	12,720		
WVF886RWT		240V	29	28	29	-	54	12,900		
WVF886EU*	NO	380-415	17	16	16	2	-	12,000		Power cord not provided
		3NAC								

*Available with optional frypot drain and 1/4-turn ball valve. RW units not available with optional frypot drain.

Minimum clearances required from unit to nearest combustible surface or object				
	BACK	SIDE	BOTTOM	TOP
inches	n/a	6	6	19
millimeters	n/a	152	152	483

FEATURES & OPERATING CONTROLS

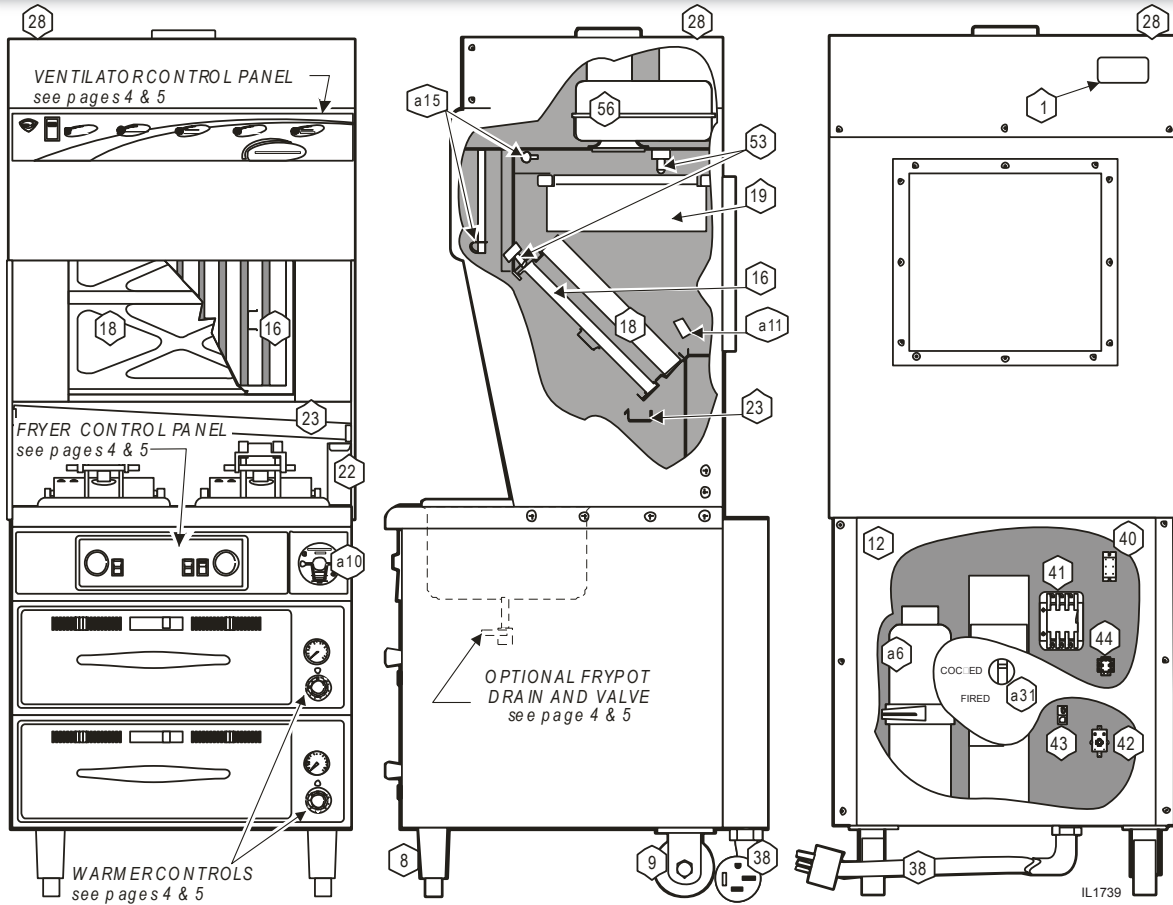

Features & Operating Controls

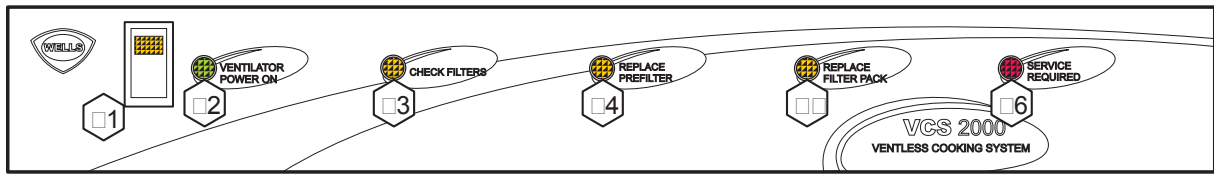

Maintenance Schedule

FEATURES & OPERATING CONTROLS (continued)

ITEM	DESCRIPTION	COMMENT
VENTILATOR SECTION		
1	NAMEPLATE	Lists Manufacturer, Model and Serial Number information. Also lists electrical specifications.
a6.	FIRE SUPPRESSION AGENT TANK (1.5 gal.)	Container for Ansul [™] Low-pH liquid fire suppression liquid.
8	ADJUSTABLE (FRONT) LEG	Allows the unit to be leveled.
9	RIGID (REAR) CASTER	Allows the unit to be easily positioned by lifting the front of the unit slightly.
a10.	MANUAL PULL STATION	Provides a means of manual activation of the fire suppression system. PULL ONLY IN CASE OF FIRE!
a11.	FUSIBLE LINKS	Automatically activates fire suppression system in the event of fire in the fryer.
12	LOWER REAR ACCESS PANEL	Allows access to Ansu [®] fire suppression agent tank (a6) and controls also access to main power contactor (41).
a15.	DISCHARGE NOZZLE	Fire suppression media discharges here (2 places).
16	GREASE BAFFLE	Extracts and drains most grease and moisture from the air flow.
18	PRE-FILTER ASSEMBLY	Comprises the PRE-FILTER FRAME and a replaceable PRE-FILTER. Stops larger particles of grease from reaching the FILTER PACK for reduced maintenance costs.
19	HEPA/CHARCOAL FILTER PACK	Stops most grease and smoke particles. Also assists in some cooking odor removal.
22	GREASE CUP	Collects grease/moisture drained from grease trough (23).
23	GREASE TROUGH	Directs grease/moisture removed by grease baffle to grease cup.
28	VENTILATOR EXHAUST DUCT	Exit point for ventilator airflow - on top left rear of unit. DO NOT BLOCK
a31.	STATUS INDICATOR	Displays status of fire suppression system (<input type="checkbox"/> O <input type="checkbox"/> <input type="checkbox"/> <input type="checkbox"/> <input type="checkbox"/> - F <input type="checkbox"/> <input type="checkbox"/> <input type="checkbox"/>). If F <input type="checkbox"/> <input type="checkbox"/> <input type="checkbox"/> , a buzzer will sound continuously.
38	POWER CORD (WHEN PROVIDED)	6' cord and cap. Plug for NEMA 15-60R (receptacle by user).
40	WARMER RELAY	Provides power to roll warmer section. Energized at all times except during fire safety shut-down.
41	POWER CONTACTOR	Energizes fryer only while ventilator section is sensed as operational.
42	BUILDING FIRE ALARM RELAY	Reports fire alarm condition to building fire management system.
43	GROUND LUG	Ground wire of power cord connects here.
44	INTERLOCK TERMINAL	Provides connection for shut-down control by building fire management system.
53	FILTER INTERLOCK SWITCHES	Proper installation of grease baffle and filter pack close these switches in ventilator sensor circuit.
56	VENTILATOR FAN	Provides air movement for ventilation.
VENTILATOR CONTROL AND INDICATOR PANEL		
V1	POWER SWITCH	Energizes blower motor. If, after 10 seconds, proper conditions are met, appliance is energized.
V2	POWER O <input type="checkbox"/> INDICATOR	GREEN. Glows when POWER switch is O <input type="checkbox"/> <input type="checkbox"/>
V3	<input type="checkbox"/> <input type="checkbox"/> <input type="checkbox"/> <input type="checkbox"/> F <input type="checkbox"/> <input type="checkbox"/> <input type="checkbox"/> <input type="checkbox"/> ALARM INDICATOR	AMBER. Glows if one or more filters are out of position. Check all filters and baffles for proper installation.
V4*	<input type="checkbox"/> <input type="checkbox"/> <input type="checkbox"/> <input type="checkbox"/> <input type="checkbox"/> <input type="checkbox"/> F <input type="checkbox"/> <input type="checkbox"/> <input type="checkbox"/> <input type="checkbox"/> ALARM INDICATOR	AMBER. Glows when PREFILTER is approaching the end of its service life and must soon be replaced.
V5*	REPLACE FILTER PACK ALARM INDICATOR	AMBER. Glows when FILTER PACK is approaching the end of its service life and must soon be replaced.
V6*	SERVICE REQUIRED ALARM INDICATOR	RED. Glows when PREFILTER and/or FILTER PACK has reached the end of its service life and is too loaded to allow sufficient air flow. Filter MUST be replaced. Appliance is <input type="checkbox"/> <input type="checkbox"/> <input type="checkbox"/> <input type="checkbox"/> <input type="checkbox"/> O W <input type="checkbox"/> until expended filters are replaced.

See O F O M , pages 6 & 7 for special procedures regarding prefilters and filter packs.

FEATURES & OPERATING CONTROLS (continued)

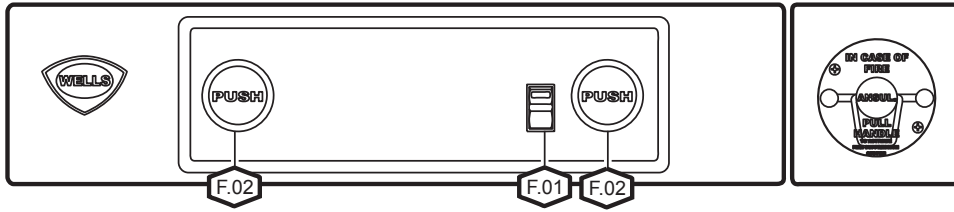

F.03 Fryer Control Panel - Front Panel Controls

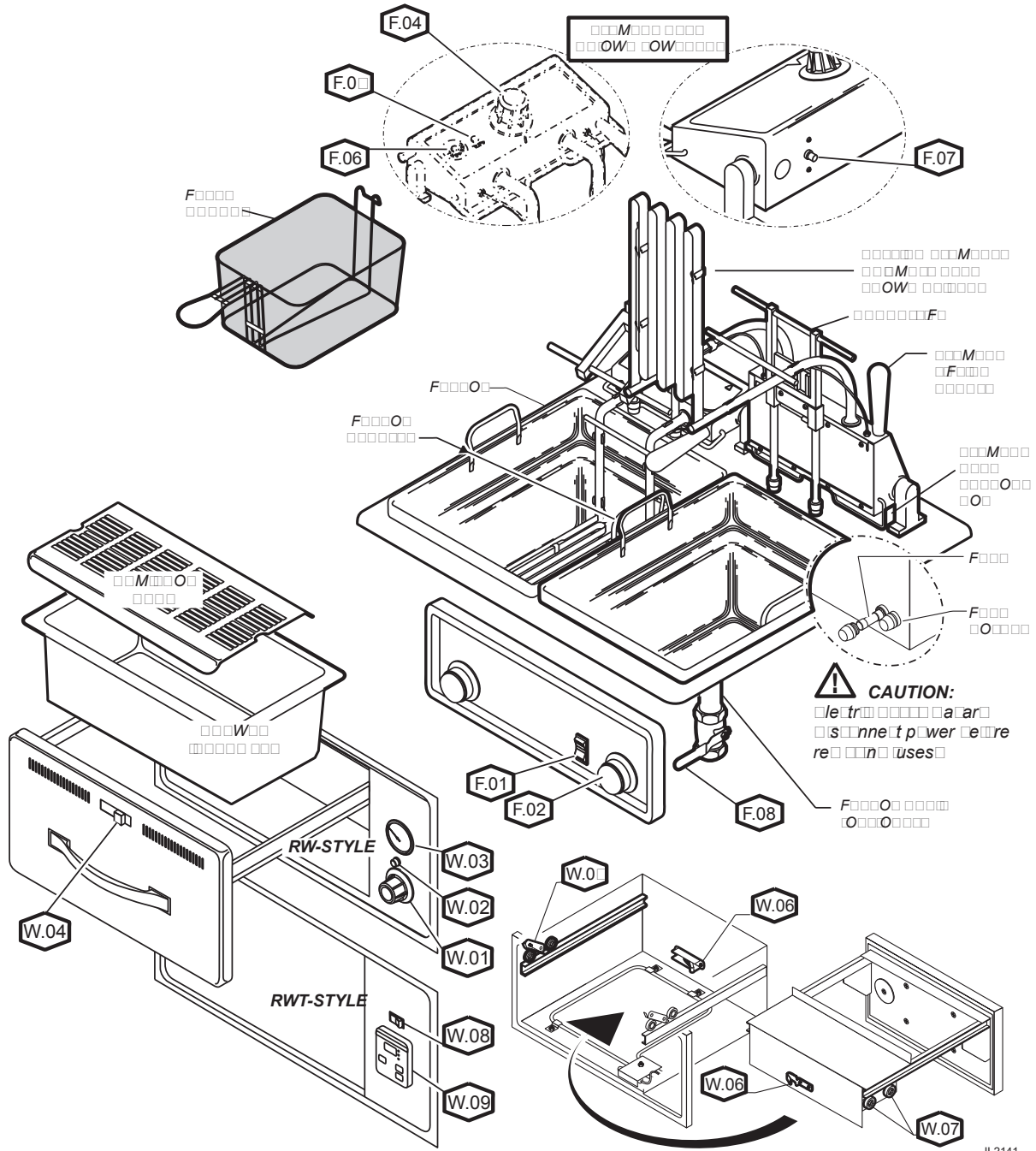

F.04 Fryer Drawer Warmer - Operating Features and Controls

FEATURES & OPERATING CONTROLS (continued)

ITEM	DESCRIPTION	COMMENT
FRYER SECTION CONTROLS		
F.01	POWER SWITCH	Turns fryer section on or off .
F.02	TIMER	Set to desired time, press to lower basket and begin timed cook cycle.
F.04	TEMPERATURE CONTROL THERMOSTAT	Set to desired cooking temperature.
F.05	HEAT INDICATOR	AMBER. Glows when heating element is energized.
F.06	TROUBLE INDICATOR	RED. Glows if safety thermostat is tripped.
F.07	HI-LIMIT RESET	Allows hi-limit safety thermostat to be reset after oil has cooled below 400°F.
F.08	DRAIN VALVE	Optional frypot drain. Valve is 1/4-turn ball valve. NOTE: Drain not available on RW (roll warmer) units
OPTIONAL WARMER SECTION CONTROLS		
W.01	WARMER TEMPERATURE CONTROL	Infinite switch control of temperature of one warmer drawer.
W.02	POWER ON INDICATOR	AMBER. Glows when associated temperature control is turned <input type="checkbox"/> <input type="checkbox"/>
W.03	THERMOMETER (optional)	Reads temperature inside drawer cavity. Must be ordered at time of initial build.
W.04	HUMIDITY CONTROL	Slide control of shutters to control air circulation within the warmer drawer.
W.05	DRAWER CATCH	Holds drawer closed.
W.06	DRAWER STOP	Prevents drawer from opening too far. Spring loaded to permit easy removal of drawer.
W.07	DRAWER ROLLERS	Support drawer and allow it to open and close smoothly.
W.08	POWER SWITCH (RWT)	Energizes unit (RWT-style only)
W.09	CONTROLLER (RWT)	Controls cavity temperature. Readout displays setpoint and actual temperature information. UP ARROW / DOWN ARROW keys allow modification of setpoint temperature. (RWT-style units only)

PRECAUTIONS AND GENERAL INFORMATION



DANGER: BURN HAZARD

Contact with hot oil will cause severe burns. Always wear protective clothing and heat resistant gloves when operating the fryer or filtering the oil.



WARNING: ELECTRIC SHOCK HAZARD

All servicing requiring access to non-insulated components must be performed by qualified service personnel. DO NOT open any access panel that requires the use of tools. Failure to heed this warning may result in severe electric shock.



CAUTION: BURN HAZARD

Contact with hot oil may cause burns. DO NOT fill fryer beyond MAX OIL line on frypot. For disposal of oil use only a container specifically designed for the disposal of hot oil. DO NOT fill hot oil disposal container beyond MAX OIL line.



CAUTION: RISK OF DAMAGE

DO NOT connect or energize this appliance until all installation instructions are read and followed. Damage to the appliance will result if these instructions are not followed.

NOTE: This entless Cooking System™ is designed to help reduce odor emissions, but will not completely eliminate cooking odors. Air exchange at the installation site must comply with the requirements of the local jurisdictional authority. To ensure that odors do not build-up, recommended minimum air exchange is 300 - 400 cfm of outside air into and out of the area where the unit is used.

IMPORTANT:

DO NOT submerge pre-filter or filter pack in water.

NOTE: Fire suppression system and all associated components must only be serviced by an authorized Ansul Distributor. All setup, charging, repair and/or adjustment of the fire suppression system must be performed by an Authorized Ansul Distributor ONLY.

IMPORTANT: If a remote pull station is installed, both rear casters (9) must be replaced with legs to deter moving the unit. **MOVING AN APPLIANCE WITH A REMOTE PULL STATION WILL DISCHARGE THE FIRE SUPPRESSION SYSTEM.**

This appliance is for use in commercial establishments only.

This appliance is intended to prepare food for human consumption. No other use is authorized by the manufacturer or its agents.

Operators of this appliance must be familiar with the appliance use, limitations and associated restrictions. Operating instructions must be read and understood by all persons using or installing this appliance.

Cleanliness of this appliance is essential to good sanitation. Read and follow all included cleaning instructions and schedules to ensure the safety of the food product.

Disconnect this appliance from electrical power before performing any maintenance or servicing.

Do not splash or pour water on, in or over any exposed element, control, control panel or wiring.

The technical content of this manual, including any wiring diagrams, schematics, parts breakdown illustrations and/or adjustment procedures, is intended for use by qualified technical personnel.

Any procedure which requires the use of tools must be performed by a qualified technician.

This manual is considered to be a permanent part of the appliance. This manual and all supplied instructions, diagrams, schematics, parts breakdown illustrations, notices and labels must remain with the appliance if it is sold or moved to another location.

This appliance is made in the USA. Unless otherwise noted, this appliance has American sizes on all hardware.

PRECAUTIONS AND GENERAL INFORMATION (continued)

OPERATIONAL NOTES:

REPLACE PREFILTER and REPLACE FILTER PACK indicator lights provide a timely warning that a system shut-down is imminent.

The actual time between the indicator light coming on and the loss of cooking appliance power will depend upon the cooking conditions.

Anytime a dirty pre-filter is replaced, the system airflow will increase. If the condition of the FILTER PACK is marginal, the REPLACE filter pack light could then come on. If this happens, a fresh filter pack must be installed within a reasonably short time.

Loss of airflow through the old filter pack will soon cause a system shut-down when the airflow falls below minimum vapor capture levels.

□□□□□□□□ F□□□□ □□□□□ O□ □□□□□

IMPORTANT: If you decide to “get the most” out of the old filter pack, and continue to use it until a system shut-down happens, it is advisable to have a fresh filter pack readily at hand, and have someone available who is capable of replacing it. Otherwise, you may experience an extended down time, with consequent associated loss of business.

The manufacturer assumes no liability for loss of business due to a system shutdown caused by a dirty pre-filter and/or filter pack (i.e. red SERVICE REQUIRED light is on), when the user fails to have the proper replacement pre-filter and/or filter pack on hand. Use only genuine Wells replacement parts and filters, call (314) 678-6314 or your authorized Wells service agent. Parts supplied by others will void your warranty and may not provide safe operation.

The Ventless Cooking System™ hood is designed as part of a WELLS fryer appliance only. No other use of this product is recommended or authorized by the manufacturer or its agents. Wells Mfg. assumes no liability for the use of this equipment with products by any other manufacturer's, or for use of this equipment with any Wells Manufacturing product other than in factory certified applications.

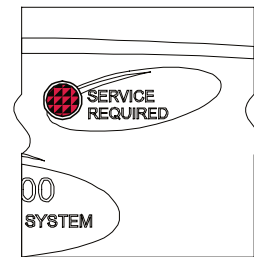
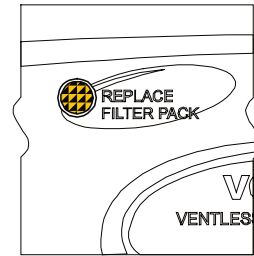
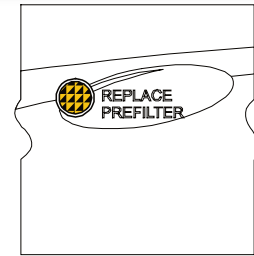

F□□□5 Ventilator
Warning
Indicators

AGENCY LISTING INFORMATION

This appliance conforms to NSF Standard 4 for sanitation only if installed in accordance with the supplied *Installation Instructions* And operated and maintained in accordance with the instructions in this manual.

This appliance is  and  listed under UL File E146882.

This appliance is evaluated to BOCA, ICBO and SBCCI Building Code Requirements by National Evaluation Service, Inc. (NES) under Report No. NER-620.



E146882



E146882



STD 4



Report No.
NER-620



UL710B CATEGORY KNKG
RECIRCULATING SYSTEM
E146887

INSTALLATION

NOTE: DO NOT discard the carton or other packing materials until you have inspected the appliance for hidden damage and tested it for proper operation.

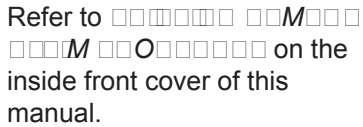
Refer to  on the inside front cover of this manual.



WARNING: RISK OF INJURY

Installation procedures must be performed by a qualified technician with full knowledge of all applicable electrical codes. Failure can result in personal injury and property damage.

UNPACKING & INSPECTION

Carefully remove the appliance from the carton. Remove all protective plastic film, packing materials and accessories from the Appliance before connecting electrical power or otherwise performing any installation procedure.

Carefully read all instructions in this manual and the Installation Instruction Sheet packed with the appliance before starting any installation.

Read and understand all labels and diagrams attached to the appliance.

Carefully account for all components and accessories before discarding packing materials. Store these components in or near the appliance for later use. To prevent loss, these items should be installed as soon as possible.

1 ea. FIRE SUPPRESSION AGENT (ANSULEX® Low pH, 1.5 GAL.)
See Material Safety Data Sheet, page 27.

1 ea. FIRE SUPPRESSION MEDIA TAN

1 ea. FIRE SUPPRESSION TAN CHARGING CARTRIDGE

1 ea. GREASE BAFFLE

1 ea. FILTER PAC ASSEMBLY

1 ea. PRE-FILTER HOLDER with PRE-FILTER

1 ea. GREASE CUP

1 ea. GREASE TROUGH

2 ea. 6" SIDE SPACERS

1 ea. LITERATURE PACKAGE

2 ea. FRYPOTS (with or without optional drain)

2 ea. FRYER BASKETS

Additionally:

2 ea. DRAWER INSERTS (if ordered with warmer drawers)

2 ea. HUMITROL RACS (if ordered with warmer drawers)

2 ea. DRAIN VALVE ASSEMBLIES (for units with optional drain only)

SETUP

Setup the appliance only on a firm level surface. Non-combustible material is recommended.

Refer to the Installation Instruction Sheet for required clearances. Maintain required clearances between the appliance and adjacent combustible surfaces. Verify 6" left and right side clearances to combustible construction. This appliance requires a minimum of 8 ft (96") (floor to overhead) to allow for adequate exhaust.

Verify that the VENTILATOR HOOD ASSEMBLY is properly and securely assembled to the cooking appliance before beginning the installation procedure.

If a remote manual pull station is to be installed, replace the rear casters with legs.

Level the unit after it is in its final position. Using a spirit level, verify that the unit is level front-to-back and side-to-side.

Avoid storing flammable or combustible materials near the appliance.

INSTALLATION (continued)

SERVICE TECHNICIAN INSTALLATION NOTES

An Ansul® technician must charge and arm the fire suppression system before the ventilator blower will operate. See page 10.

Installation and start up must be performed by an Authorized Installation Company.

Installer must complete the WARRANTY REGISTRATION form, and record appliance installation particulars on the CUSTOMER SERVICE DATA form in this manual.

Certain codes require cooking equipment to be restrained with a RESTRAINT DEVICE. It is the RESPONSIBILITY OF THE INSTALLER to check with the authority having jurisdiction, in order to ascertain the applicability of this requirement to this specific EQUIPMENT installation. Any restraint device must allow access to the back and sides of the unit to provide for servicing and maintenance, and must not interfere with the operation of the FIRE SUPPRESSION SYSTEM.

ELECTRICAL INSTALLATION

Refer to the nameplate on the cooking appliance to verify the ELECTRICAL SERVICE POWER. Voltage and phase must match the nameplate specifications, and available electrical service amperage must meet or exceed the specifications listed on page 1. Incoming wiring must comply with National Electrical Code specifications.

All 3Ø fryer / universal hood appliances (except EU units) ship from the factory with a 3Ø cordset.

All 1Ø fryer / universal hood appliances; and, all EU fryer / universal hood appliances must be wired directly to the electrical circuit. Most jurisdictions require an approved electrical disconnect to be installed in the branch circuit, in near proximity to the appliance.

Field conversion of 3Ø appliances to 1Ø is neither recommended nor authorized by Wells Manufacturing Co.

IMPORTANT!

Verify that this VENTILATOR and food cooking equipment installation is in compliance with the specifications listed in this manual, with local code requirements, and in accordance with N.F.P.A 96 (THE STANDARD FOR VENTILATION CONTROL AND FIRE PROTECTION OF COMMERCIAL COOKING OPERATIONS - current edition).

THIS IS THE
RESPONSIBILITY
OF THE INSTALLER



DANGER
ELECTRIC
SHOCK
HAZARD

ELECTRIC CONNECTIONS MUST BE MADE BY A LICENSED ELECTRICIAN. Electrical shock will cause death or serious injury.

NOTE: This appliance requires a dedicated electrical branch circuit with 50 Amp protection for 3Ø; or, 80 Amp protection for 1Ø.

IMPORTANT:

Contact a licensed electrician to install and connect electrical power to the appliance.

IMPORTANT:

Damage due to being connected to the wrong voltage or phase is NOT covered by warranty.

INSTALLATION (continued)



**DANGER
FIRE
HAZARD**



THE FIRE SUPPRESSION SYSTEM MUST BE CHARGED AND CERTIFIED BY AN AUTHORIZED ANSUL DISTRIBUTOR. NEVER ATTEMPT TO MODIFY OR BYPASS THE FIRE SUPPRESSION SYSTEM.

AN UNCONTROLLED FIRE CAN CAUSE SERIOUS INJURY, DEATH AND/OR PROPERTY LOSS.

IMPORTANT: The FIRE SUPPRESSION SYSTEM must be SET-UP and CHARGED by an authorized Ansul distributor before the ventilator blower will operate.

NOTE:

If the fire suppression system is discharged, a buzzer will sound continuously and the cooking appliance will remain inoperable until the fire suppression system is serviced.

Recharging and resetting must be performed by an authorized Ansul distributor ONLY.

Charging of the Ansul Fire Suppression system must be in accordance with Ansul Design, Installation, Recharge and Maintenance Manual. (Ansul® #418087-05)

FIRE SUPPRESSION SYSTEM INSTALLATION

1. Any REMOTE MANUAL PULL STATION must be installed by an authorized ANSUL distributor in accordance with the AUTHORITY HAVING JURISDICTION.

NOTE: If a REMOTE MANUAL PULL STATION is installed, moving the unit for servicing will cause the Ansul system to discharge. In this case, the unit must only be installed with four fixed legs (i.e. remove rear casters and replace with legs). Additional legs may be ordered through an Authorized Wells Service Agency. See page 29.

2. The FIRE SUPPRESSION SYSTEM is comprised of a pressurized cartridge & container of liquid fire suppressant, with associated plumbing and controls. It utilizes factory installed FUSIBLE LINKS for automatic actuation, and a factory installed MANUAL PULL STATION for manual actuation. Two NOZZLES are used to disperse the liquid fire suppression media.

3. When the fire suppression system activates, the fire suppression media is discharged, both the cooking appliance and the ventilator are de-energized, and a buzzer will sound continuously. The fire suppression media will form an emulsion designed to both smother and cool the fire.

Call your Authorized Ansul Distributor immediately for service.

NOTE: See page 27 for the Material Safety Data Sheet for the fire suppression agent.

4. The MANUAL PULL STATION and any similar REMOTE MANUAL PULL STATION will activate the fire suppression system when the ring on the pull station is pulled horizontally.

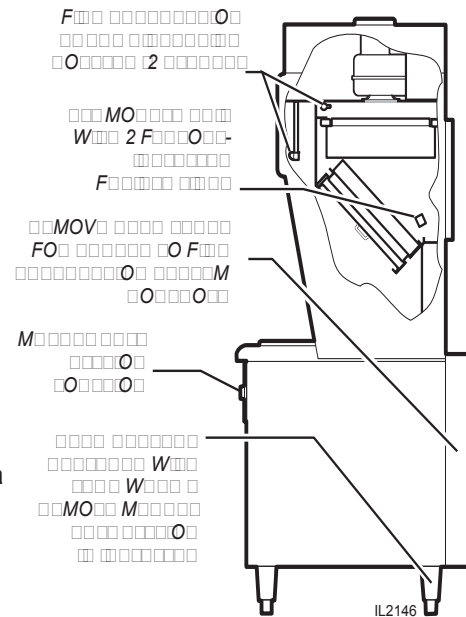

Figure 6 Fire Suppression System

INSTALLATION (continued)

FILTERS INSTALLATION

1. **FILTER PAC**: Ships installed in the hood. If the **FILTER PAC** is not in position, the **CHECK FILTERS** indicator will light. If the **FILTER PAC** becomes clogged, the **REPLACE FILTER PAC** indicator will glow.

To install the **FILTER PACK**: Position the filter pack with the charcoal portion UP. Slide the filter pack toward the rear of the unit until it contacts the guides on the back panel. Push the filter pack UP into the upper opening until it rests firmly against the filter pack seal. When up in position, holder clips can be snapped over wall ledge on each side. To remove **FILTER PAC**: Grasp both holder clips and pull INWARD until the clips clear the sidewall ledge. Then, pull the filter pack down and out.

2. **PRE-FILTER**: The **PRE-FILTER** ships in the **FILTER FRAME**. If the **PRE-FILTER** is not in position, or if the **PRE-FILTER** is not in the **FILTER FRAME**, the **CHECK FILTERS** indicator will light. If the **PRE-FILTER** becomes clogged, the **REPLACE PRE-FILTER** indicator will glow.

To install the **PRE-FILTER**: Pay attention to the air flow markings. The **AIR FLOW** arrow will point away from the installer. Slide the assembly up into the front opening, behind the upper filter rail. While pressing slightly against the bottom of the assembly, pull the **FILTER HANDLE** toward you so as to engage the **FILTER HOOK** over the lip of the top filter rail. Then lower and seat the assembly into the top indentation of the lower filter rail.

3. **GREASE BAFFLE**: If the **GREASE BAFFLE** is not in place, the **CHECK FILTERS** indicator will glow. To install the **GREASE BAFFLE**: Slide the grease baffle up into the indentation of the upper filter rail, then lower and seat it into the bottom indentation of the lower filter rail. Pull toward you and downward to verify the **GREASE BAFFLE** is properly seated in the lower frame rail.

NOTE:

The **GREASE BAFFLE** and **FILTER PAC** activate mechanical switches, and the **PRE-FILTER** activates a vacuum switch, to verify that the filter elements are in their proper positions. All filter elements must be properly installed or the cooktop will not be energized. Also, the **REPLACE PRE-FILTER** indicator will light.

IMPORTANT:

The filter hook prevents the **PRE-FILTER** from being drawn in during operation. After installation, press against the top of the filter frame to verify proper engagement of the filter hook over the lip of the top filter rail.

Use only genuine Wells replacement parts and filters, call (314) 678-6314 or your authorized Wells service agent. Parts supplied by others will void your warranty and may not provide safe operation.

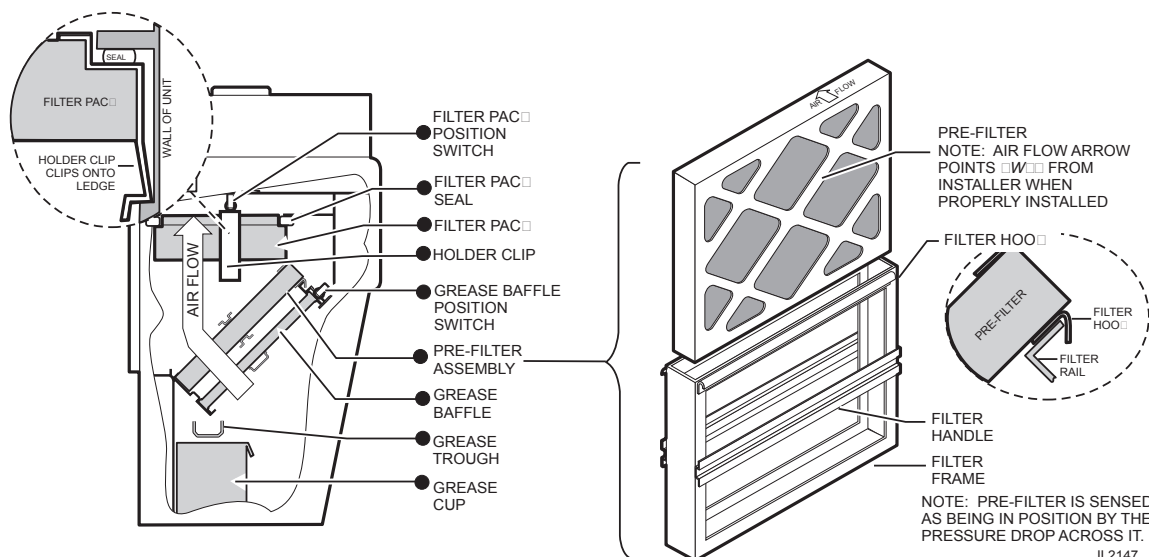

Filter Installation

INSTALLATION (continued)



WARNING
SLIP / FALL
HAZARD
SPILLED OIL



DO NOT OPERATE UNLESS
THE GREASE CUP
AND TROUGH
ARE INSTALLED.

Oil and moisture will drip onto
the floor and falls may result.
Death or serious injury may
result from slipping and falling

On units with optional frypot
drains, be sure drain valves
are left in the closed position.

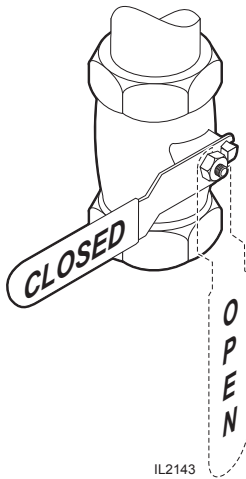

F8a Frypot Drain Valve
Operation

GREASE TROUGH AND GREASE CUP INSTALLATION

1. Install the GREASE TROUGH into the brackets below the grease baffle.
2. Install the GREASE CUP on the right side of the unit, directly below the grease trough.

FRYPOT INSTALLATION

1. Using the lifting handle, raise the element head. The support rod is spring loaded and will move into place to support the head.
2. Install the frypot in the cutout beneath the element head.
3. Lift the element head slightly, then move the element support rod forward to allow the head to lower.
4. Gently lower the element head into the frypot.

ROLL WARMER DRAWER INSTALLATION

1. Be sure roller catches (inside warmer cavity) are in the open position. Install drawer assemblies in drawer slides.
2. Place appropriate one drawer insert pan into each warmer drawer. If used, place one Humitrol rack into each drawer pan.

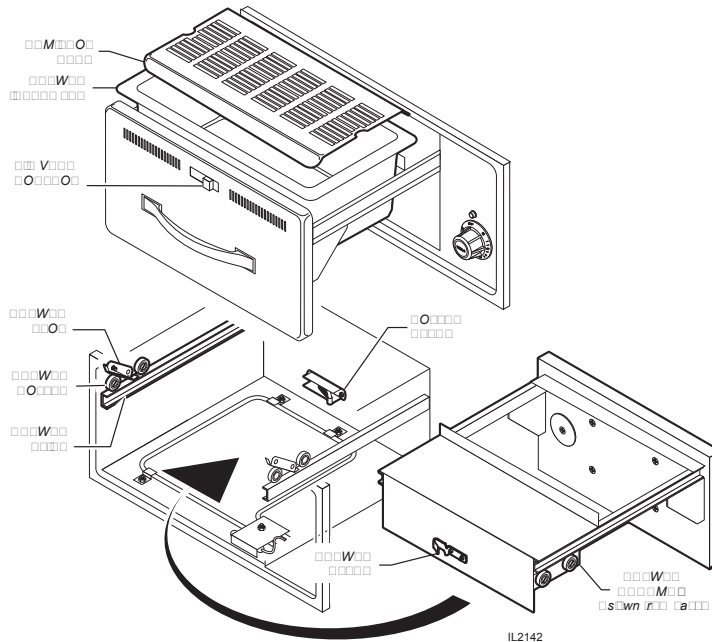

F8 Roll Warmer Drawer Installation

OPERATION

VENTILATOR OPERATION

BE SURE BOTH FRYER SWITCHES ARE OFF.

1. Press the **VENTILATOR POWER** switch to ON. The green **VENTILATOR POWER ON** light will glow and the blower fan will start. After a short time, if all filters are sensed as being in position and not clogged, the cooktop will be energized. The roll warmer is energized at all times.

During normal operation, the **VENTILATOR POWER ON** light will be the only light glowing on the upper control panel.

2. If the amber **FILTER** light glows, one or more filter elements is out of position. Check the GREASE BAFFLE, PRE-FILTER and FILTER PACK for proper installation in their respective positions. Grease baffle and filter pack position are sensed by mechanical switches. Pre-filter position is sensed by a vacuum switch.
3. When the amber **PRE-FILTER ELEMENT** light glows, the pre-filter is nearing the end of its service life. Replace the disposable PRE-FILTER ELEMENT.
4. When the amber **FILTER PACK** light illuminates, the HEPA / Charcoal filter pack is nearing the end of its service life. Replace the FILTER PACK.

Note: The **PRE-FILTER ELEMENT** and **FILTER PACK** lights are a warning that the indicated filter is near the end of its service life. The appliance will continue to operate for a period of time after the light glows to allow continued operation through a peak period. However, the indicated filters must be replaced within a reasonably short time period or they will clog and shut down electrical power to the cooktop. The ventilator blower will continue to run.

5. When the red **VENTILATOR SYSTEM** light glows, either the pre-filter or filter pack (or both) is clogged and can no longer pass sufficient air to allow further operation. The ventilator fan continues to run, but the cooktop is shut down until the underlying clogged filter situation has been corrected. This can occur when neither **PRE-FILTER ELEMENT** indicator light is lit, if both pre-filter and filter pack are marginal. Replacing both the pre-filter and the filter pack will remedy the situation.

Note: replacing the pre-filter, even though not very dirty, will often extend the service life of the more expensive filter pack. Reset the unit by turning the **VENTILATOR POWER** switch to OFF, then back ON.

6. A failure of incoming electrical power will cause a shut down of the unit. After power is restored, reset the unit by turning the **VENTILATOR POWER** switch to OFF, then back ON.



**CAUTION:
HOT SURFACE**

Exposed surfaces can be hot to the touch and may cause burns.

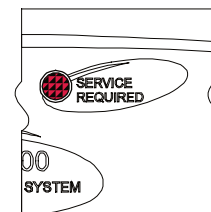
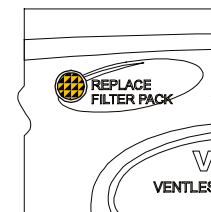
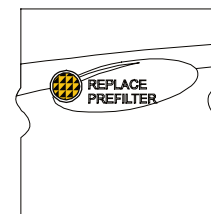
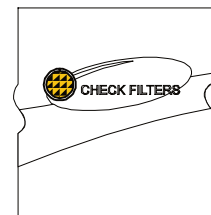
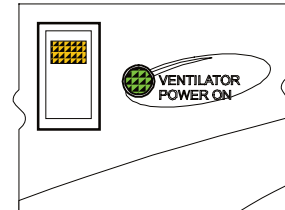

**F9 Ventilator Indicator
and Warning Lights**

OPERATION (continued)



DANGER: BURN HAZARD

Contact with hot oil will cause severe burns.
Always wear protective clothing and heat resistant gloves when operating the fryer.



CAUTION: HOT SURFACE

Exposed surfaces can be hot to the touch and may cause burns.

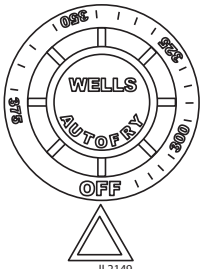

Fryer Temperature Control Knob

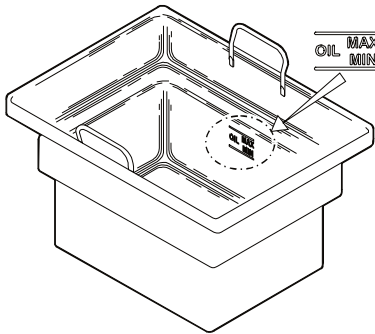

Fryer Frypot Oil Level Markings



Fryer Timer

NOTE: If the oil temperature exceeds 440°F, hi-limit safety will shut down the unit, and red THERMOPROTECT light will glow. To reset: Allow the oil to cool, then press the red button on the back of the element head until it “clicks” and stays in. If tripping persists, see Troubleshooting Suggestions, page 23.

FRYER OPERATION

NOTE: The two sections of the fryer are completely separate, and can be used and controlled individually.

1. a. Be sure the TEMPERATURE CONTROL knob is turned to OFF.
b. Lower the element head into the frypot by pulling back on the ELEMENT LIFTING HANDLE, raising the ELEMENT HEAD SUPPORT ROD, then carefully lowering the elements into the frypot.

IMPORTANT:

On units equipped with frypot drains, be sure both drain valves are closed.

IMPORTANT:

DO NOT overfill the frypot. Cold oil will expand as it heats. Adding too much oil will allow the frypot to overflow during operation.

Fill the FRYPOT with commercial-grade liquid shortening to the MIN OIL line.

Capacity: 30 pounds (15 pounds each frypot).

For best results, always use top grade commercial shortening made specifically for frying.

Maintain proper oil level in frypot during operation.

3. Turn the TEMPERATURE CONTROL knob to the desired temperature. The HEAT INDICATOR will glow. When the oil reaches the desired temperature, the heat indicator will go out. The heat indicator will go off and on during operation as the thermostat cycles to maintain temperature.

For best results: DO NOT set temperature control to a temperature setting higher than is required for the food product.

4. Load either or both baskets no more than 1/2 full with food product. DO NOT overload fry baskets. For best results, load baskets uniformly to half full. Hang the basket on the BASKET LIFT.
5. Set the TIMER DIAL to the desired cooking time. Press the red button on the timer to lower the basket into the hot oil. When food is cooked, the basket will be lifted out of the oil. Handle the hot basket only by the basket handle.
6. When the heat indicator light cycles off, the fryer is ready to cook the next load.
7. Reduce temperature control to 225°F during idle periods to save power and extend the life of the oil. The fryer will return to operating temperature in just a few minutes when needed.
8. Keep the fryer clean at all times. Rinse baskets frequently, and dry thoroughly, in order to prevent oil contamination.
9. Drain the frypot completely after use. Filter the oil daily, or more often during heavy use.

OPERATION (continued)

DRAWER WARMER OPERATION (WHEN PROVIDED) HEATING OPTIONS

1. Moist heat with Humitrol Rack:
 - a. MOIST operation prevents food from drying out as moisture, as well as heat, is applied to the warming chamber.
 - b. To set for MOIST operation, remove Humitrol Rack from bottom of drawer insert pan and carefully pour approximately 2 quarts of water (½" depth) into the pan. Reinstall rack.
 - c. The Humitrol Rack decreases the sloshing effect of the water in the pan when the drawer is opened. When the drawer is closed, the Humitrol Rack allows steam to rise through the stored product in the drawer.
 - d. Place the food directly on the rack. The rack is designed to support the food off of the steam vents, where water droplets may form.
 - e. Check the water level in the pan periodically, and add water when necessary.
 - f. Set the front air vent between fully closed and half-open. Actual setting will depend upon the type and amount of product stored in the drawer, the temperature setting, and the frequency with which the drawer is opened.
2. Moist heat with pans:
 - a. This Wells warmer is designed to accommodate any combination of standard-size, steam table pans.
 - b. Place a small amount of water in drawer pan. Place pans in drawer pan.
 - c. Check the water level in the pan periodically, and add water when necessary.
3. Dry heat:
 - a. For some applications, you may want to store previously prepared foods in a dry-heat environment. To do so, place the food directly into the empty (i.e. no water) drawer pan.



**CAUTION:
HOT SURFACE**

Exposed surfaces can be hot to the touch and may cause burns.

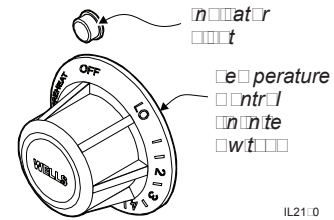

Figure 4 Wells Warmer
Temperature Control

NOTE:

The chart below is intended as a guide ONLY. Your own experience with this appliance, type of foods and method of operation will enable you to determine the temperature control and air vent settings best suited to your operation.

OPERATING CHART FOR DRAWER WARMERS

PRODUCT TYPE	RECOMMENDED STORAGE TEMP.	TYPE OF HEAT	CONTROL SETTING	AIR VENT SETTING
Hard Rolls	160-185°F	Dry	7-8	Closed
Soft Rolls	150-175°F	Moist	6-7	Open - ½
Vegetables	175-185°F	Moist	7-8	Open - ½
Meats	165-185°F	Dry	6-8	Closed
Fish	165-185°F	Moist	6-8	Open
Casseroles	150-175°F	Dry	6-7	Closed
Pies, Desserts	160-185°F	Dry	6-7	Closed

OPERATION (continued)

DRAWER WARMER OPERATION (when provided)

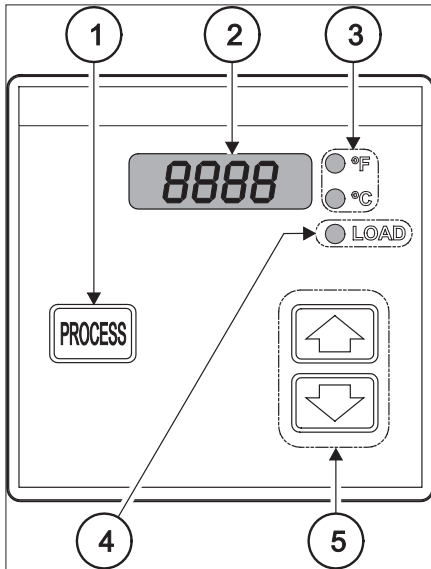

ITEM	DESCRIPTION
1	PROCESS key: Press to view actual temperature of cavity.
2	4 Character LED Display: Normally shows SETPOINT temperature.
3	°F or °C Indicator: Glow to indicate if unit is configured for degrees Fahrenheit or degrees Celsius.
4	LOAD Indicator: Glow when heating element is energized.
5	Increment and Decrement keys: Press UP arrow to increase Press DOWN arrow to decrease

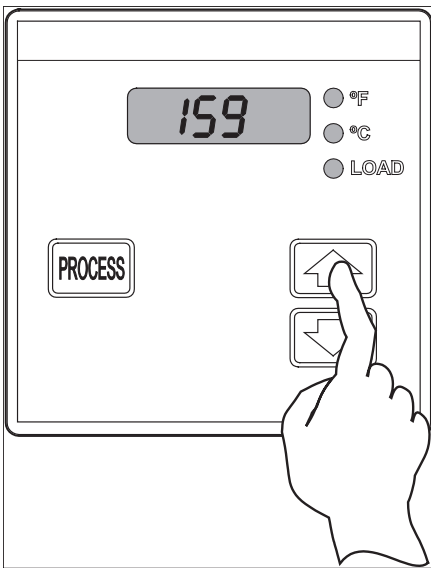

RWT - CONTROL MODULE

SET SETPOINT TEMPERATURE

Press an arrow key:

UP arrow to increase

DOWN arrow to decrease

Release key when desired setpoint temperature is displayed.

Reading is locked into memory 3 seconds after last key stroke.

Minimum setpoint is 140°F (60°C)

Maximum setpoint is 250°F (121°C)

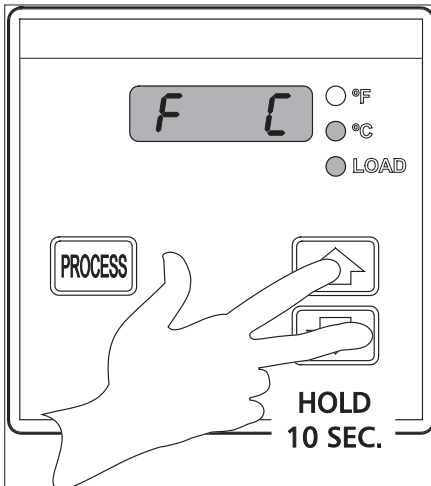

CHANGE DISPLAY MODE (°F or °C)

Press and hold UP arrow and DOWN arrow keys for 10 seconds.

Release keys when display reads F C.

Within 3 seconds, press UP arrow or DOWN arrow key until desired indicator (°F or °C) glows.

The new value will lock into memory 3 seconds after last keystroke.

CLEANING INSTRUCTIONS

PREPARATION Disconnect appliance from electric power
Allow to cool before cleaning

FREQUENCY Weekly

TOOLS Warm water and a mild detergent
Soft clean cloth or sponge
Bristle brush



**CAUTION:
ELECTRIC
SHOCK HAZARD**

Disconnect appliance from electric power before cleaning.

ROLL WARMER SECTION

1. Disconnect appliance from electric power
Allow to cool before cleaning
2. Remove roll warmer drawers, drawer inserts and Humitrol racks.
3. Brush crumbs from drawer slides and interior of warmer cavity with a bristle brush.
4. Wash and rinse the drawer inserts and Humitrol racks in a sink or dishwasher using mild detergent and warm water. Allow to air dry.
5. Reassemble and reinstall warmer drawers.

Procedure is complete



**CAUTION:
HOT SURFACE**

Exposed surfaces can be hot to the touch and may cause burns. Allow appliance to cool before cleaning.

IMPORTANT:

DO NOT spill or pour water into controls, control panel, wiring. Damage to internal components will occur. Damage to internal components from water damage is **not** covered by warranty.

IMPORTANT:

DO NOT use steel wool or metal implements to clean drawers or cabinet surfaces.

CLEANING INSTRUCTIONS (continued)



CAUTION: ELECTRIC SHOCK HAZARD

Disconnect appliance from electric power before cleaning.



CAUTION: HOT SURFACE

Exposed surfaces can be hot to the touch and may cause burns. Allow appliance to cool before cleaning.

IMPORTANT:

Never allow PRE-FILTER or FILTER PAC□ to get wet. DO NOT wash either of these two filters. Washing these filters will ruin them and cause the appliance to shut-down.

IMPORTANT:

DO NOT spill or pour water into controls, control panel, wiring or coil-type hotplate elements. Damage to internal components will occur. Damage to internal components from water damage is **not** covered by warranty.

IMPORTANT:

DO NOT use steel wool or metal implements to clean cabinet surfaces.

VENTILATOR WEEKLY CLEANING

PREPARATION: Disconnect appliance from electric power
Allow to cool before cleaning

FREQUENCY: Weekly

TOOLS: Warm water and a mild detergent
Soft clean cloth or sponge
Bristle brush
Container for disposal of grease

1. Disconnect appliance from electric power
Allow to cool before cleaning
2. Remove the grease baffle, pre-filter assembly, grease trough and grease cup. Empty the grease trough and grease cup.
3. **IMPORTANT:**
Never allow PRE-FILTER or FILTER PAC□ to get wet.
DO NOT wash either of these two filters. Washing these filters will ruin them and cause the appliance to shut-down.
Remove the pre-filter from the filter frame.
Wash and rinse the *filter frame* ONLY.
4. Wash and rinse the grease baffle, grease trough and grease cup in a sink or dishwasher using mild detergent and warm water.
Allow to air dry.
5. Reinsert the pre-filter into the filter frame. Reinstall the pre-filter, grease baffle, grease trough and grease cup.

Procedure is complete

CLEANING INSTRUCTIONS (continued)

VENTILATOR MONTHLY CLEANING

PREPARATION:	Disconnect appliance from electric power Allow to cool before cleaning
FREQUENCY:	Monthly
TOOLS:	Warm water and a mild detergent Soft clean cloth or sponge Plastic scouring pad, plastic scraper Container for disposal of grease



**CAUTION:
ELECTRIC
SHOCK HAZARD**

Disconnect appliance from electric power before cleaning.



**CAUTION:
HOT SURFACE**

EXTERIOR

Wash exterior surfaces with a soft clean cloth or sponge dampened with warm water, mild soap or detergent. Rinse with a soft clean cloth or sponge dampened with warm water. Allow to air dry.

Exposed surfaces can be hot to the touch and may cause burns. Allow appliance to cool before cleaning.

INTERIOR:

In addition to the weekly cleaning procedure, remove the filter pack.

Cover the griddle section. Wash the interior surfaces of the ventilator with warm water, mild soap or detergent and a clean, soft cloth or sponge. Stubborn or burned-on food debris may be removed with a plastic scouring pad or plastic scraper.

Dry thoroughly with a clean soft cloth.

Uncover the griddle and reassemble the ventilator.

Procedure is complete.

IMPORTANT:

Never allow PRE-FILTER or FILTER PAC to get wet. DO NOT wash either of these two filters. Washing these filters will ruin them and cause the appliance to shut-down.

IMPORTANT:

DO NOT spill or pour water into controls, control panel, wiring or coil-type hotplate elements. Damage to internal components will occur. Damage to internal components from water damage is not covered by warranty.

IMPORTANT:

DO NOT use steel wool or metal implements to clean cabinet surfaces.

CLEANING INSTRUCTIONS



DANGER: BURN HAZARD

Contact with hot oil will cause severe burns. Allow the fryer to cool before cleaning. Always wear protective clothing and heat resistant gloves when cleaning the fryer.



CAUTION: ELECTRIC SHOCK HAZARD

Disconnect fryer from electric power before cleaning.

PREPARATION

Turn temperature control to OFF
Allow fryer to cool completely before cleaning
Disconnect fryer from electric power before cleaning

FREQUENCY

Daily, or as needed

TOOLS

Mild Detergent, Non-abrasive cleanser
Soft Cloth or Sponge, Plastic Scouring Pad
Container for disposal of used oil.



CAUTION: BURN HAZARD

Allow fryer to cool completely before cleaning.

IMPORTANT:

Nickel plated frypot must be dried completely in order to prevent rusting, and to eliminate water contamination of the cooking oil.

To remove carbonization from elements and frypot, see □□□□O□□□ □□□□□□□□□□ page 23.

FRYER SECTION - UNITS WITHOUT DRAIN

1. Turn temperature control to OFF. Disconnect from electric power.
2. Remove fry baskets, then swing the element heads up and out of the frypots.
NOTE: The element support rod is spring-loaded. When the element head is raised, the support rod will automatically swing into position to keep the element head raised.
3. Allow the oil to cool to a safe temperature (120°F or less). Carefully remove the frypots: wearing heat-resistant gloves, lift the frypots by the handles. Drain the oil into a suitable container.
4. Frypots and baskets may be washed in a dishwasher, or with warm water and mild detergent. Rinse thoroughly and dry completely.
5. Wipe/brush all crumbs, breading and cooking debris from the elements. Pay particular attention to the area between the element and the thermobulbs. Be careful that the capillary tubes of the thermobulbs are not moved or damaged during cleaning.
6. □ Keep all exterior surfaces free from splashed grease by wiping with a clean cloth dampened with warm water and mild detergent. A non-abrasive detergent and plastic scouring pad may be used for stubborn deposits.

IMPORTANT: DO NOT use steel wool or abrasive cleansers as these will damage the surface finish.

IMPORTANT: DO NOT spill or pour water into controls, control panel or wiring. Damage to internal components will occur.

7. Be certain frypots are completely dry, then reinstall in fryer.
 - a. Be sure the TEMPERATURE CONTROL □NOB is turned to OFF, then plug unit into receptacle.
 - b. Lower the element headS into the frypot by pushing back on the ELEMENT LIFTING HANDLE, raising the SUPPORT ROD, then carefully lowering the elements.
 - c. Add new or filtered oil to the MIN OIL line in frypots.

Procedure is complete.

CLEANING INSTRUCTIONS (continued)



DANGER: BURN HAZARD

Contact with hot oil will cause severe burns. Allow the fryer to cool before cleaning. Always wear protective clothing and heat resistant gloves when cleaning the fryer.

PREPARATION	Turn temperature control to <i>OFF</i> Allow fryer to cool completely before cleaning Disconnect fryer from electric power before cleaning
FREQUENCY	Daily, or as needed
TOOLS	Mild Detergent, Non-abrasive cleanser Soft Cloth or Sponge, Plastic Scouring Pad Container for disposal of used oil.



CAUTION: ELECTRIC SHOCK HAZARD

Disconnect fryer from electric power before cleaning.



CAUTION: BURN HAZARD

Allow fryer to cool completely before cleaning.

FRYER SECTION - UNITS WITH OPTIONAL DRAIN

1. Turn temperature control to OFF. Disconnect from electric power.
2. Remove fry baskets, then swing the element heads up and out of the frypots.

NOTE: The element support rod is spring-loaded. When the element head is raised, the support rod will automatically swing into position to keep the element head raised.

3. Allow the oil to cool to a safe temperature (120°F or less). Place suitable container under the drain and open valve. Drain the oil into the container.
4. Frypots must be cleaned in place with warm water and mild detergent. Rinse thoroughly and dry completely.
5. Baskets may be washed in a dishwasher, or with warm water and mild detergent. Rinse thoroughly and dry completely.
6. Wipe/brush all crumbs, breading and cooking debris from then elements. Pay particular attention to the area between the element and the thermobulbs. Be careful that the capillary tubes of the thermobulbs are not moved or damaged during cleaning.
7. Keep all exterior surfaces free from splashed grease by wiping with a clean cloth dampened with warm water and mild detergent. A non-abrasive detergent and plastic scouring pad may be used for stubborn deposits.

IMPORTANT: DO NOT use steel wool or abrasive cleansers as these will damage the surface finish.

IMPORTANT: DO NOT spill or pour water into controls, control panel or wiring. Damage to internal components will occur.

8. Be certain frypot drain valves are closed.
 - a. Be sure the TEMPERATURE CONTROL NOB is turned to *OFF* then plug unit into receptacle.
 - b. Lower the ELEMENT HEADS into the frypot by pushing back on the ELEMENT LIFTING HANDLE, raising the SUPPORT ROD, then carefully lowering the elements.
 - c. Add new or filtered oil to the MIN OIL line in frypots.

Procedure is complete.

IMPORTANT:
Nickel plated frypot must be dried completely in order to prevent rusting, and to eliminate water contamination of the cooking oil.

To remove carbonization from elements and frypot, see , page 23.

DISPOSAL OF USED OIL



DANGER: BURN HAZARD

Contact with hot oil will cause severe burns. Allow the fryer to cool before cleaning. Always wear protective clothing and heat resistant gloves when handling hot oil.



CAUTION: BURN HAZARD

Allow fryer to cool completely before draining.

PREPARATION

Turn temperature control to *OFF*
Allow fryer to cool completely before draining

FREQUENCY

Daily, or as needed

TOOLS

Container for disposal of used oil.



CAUTION: SLIP / FALL HAZARD

Clean up oil spills immediately. Slipping in oil can cause injury.

OIL DISPOSAL

1. Turn temperature control to OFF.
2. Allow the oil to cool to a safe temperature (120°F or 50°C).
3. UNITS WITHOUT DRAIN:

Carefully remove the frypots: wearing heat-resistant gloves, raise the element head and lift the frypot out of the fryer by the frypot handles. Drain the oil into a suitable container. Wipe the frypot and reinstall in the fryer

UNITS WITH OPTIONAL DRAIN:

Place a suitable container under the drain valve. Wearing heat-resistant gloves, open the drain valve and drain the oil into the container. Close the drain valve after all oil is drained.

4. Dispose of the used oil in an approved oil disposal receptacle, or filter the oil for reuse.

Procedure is complete.



CAUTION: HEALTH HAZARD

Clean up spills immediately. Oil provides an environment for the growth of bacteria, which presents a health hazard.

MAINTENANCE



DANGER: BURN HAZARD

Contact with hot oil will cause severe burns. Allow the fryer to cool draining oil. Always wear protective clothing and heat resistant gloves when handling hot oil.

PERIODIC CLEANING

1. Add 1/2 cup of granulated dishwasher detergent to frypot. Fill with water to the MAX OIL line.
2. Lower the element into the frypot and set the control knob to 225°F
3. Boil the mixture for five minutes. Turn the control knob to OFF.

Allow the mixture to set in the frypot overnight.

4. After the soak period, raise the elements and remove any remaining carbonization with a stiff bristle brush.

IMPORTANT:

Be careful that the capillary tubes of the thermobulbs are not moved or damaged during cleaning.

5. Drain the frypot and wash with warm water and mild detergent. Rinse with clean water.
6. Reinstall the frypot in the fryer (frypots without drain), or close drain valve (frypots with optional drain).

Add 1 quart of vinegar, then fill to the MAX OIL line with cold water.

Lower the elements into the vinegar solution.

Allow to set for 15 minutes.

7. Drain the frypot and rinse with clean water. Dry the frypot and elements thoroughly before returning the fryer to operation.

IMPORTANT:

Nickel plated frypot must be dried completely in order to prevent rusting, and to eliminate water contamination of the cooking oil.

Procedure is complete.



CAUTION BURN HAZARD

This procedure involves very hot liquids.

Wear protective clothing and heat-resistant gloves.

Periodic cleaning is necessary to remove carbonization from the elements and frypot.

Frypot may be cleaned by the method described at right, or with a commercial frypot cleaner. Be sure to follow the manufacturer's directions.

Before cleaning, ALWAYS:

- Disconnect the fryer from electric power and allow to cool.
- Drain the oil and wipe out the frypot.

TROUBLESHOOTING SUGGESTIONS

DESCRIPTION	POSSIBLE CAUSE	SUGGESTED ACTION
Ventilator blower won't run	Circuit breaker tripped	Check / reset circuit breaker
Ventilator blower won't run — buzzer sounding	Ansul® fire suppression system tripped	Contact Authorized Ansul® Distributor for repairs
Ventilator blower runs momentarily, shuts down	Clogged filter , or filter out of position	Observe indicator lights, service filter(s) as required
	Damaged internal components	Contact your Authorized Wells Service Agent for repairs
□□□□□ F□□□□□ light on	Filter or grease baffle out of position	Reinstall filters / baffle
□□□□□□ □□□F□□□□ /□□□□ □□	Pre-filter clogged, but still operational	Replace pre-filter at first opportunity
□□□□□□□ F□□□□□ □□□□ /□□□□ □□	Filter pack clogged, but still operational	Replace filter pack at first opportunity
SERVICE REQUIRED light on	Pre-filter or filter pack clogged	Replace pre-filter first. If indicator stays lit, replace filter pack
Roll warmers won't heat (ventilator operational)	Damaged internal components	Contact your Authorized Wells Service Agent for repairs
Warmer drawer not hot enough	Temperature control not set	Set control to desired temp
Product in warmer drawer too dry or wet	Humidity control not set	Set for desired humidity

NOTE: There are no user serviceable components in the appliance.

- A. In all cases of damage or component malfunction, contact your Authorized Wells Service Agency for repairs.
- B. For service of the fire suppression system, contact an Authorized Ansul® Distributor.

TROUBLESHOOTING SUGGESTIONS (continued)

DESCRIPTION	POSSIBLE PROBLEM	SUGGESTED REMEDY
Fryer will not heat	Not plugged in or circuit breaker tripped	Plug into proper receptacle Reset circuit breaker
	Fuse blown	Contact Wells Authorized Service Agency for repairs
	Temperature control knob not set to desired temperature	Set to desired temperature
	Hi-limit safety tripped	Clean element ¹ , reset hi-limit
	Damaged internal component	Contact Wells Authorized Service Agency for repairs
Fryer will not maintain temperature	Temperature control thermostat thermobulb contaminated with cooking debris	Clean element ²
	Damaged internal component	Contact Wells Authorized Service Agency for repairs
Fryer leaks oil	Damaged frypot	Contact Wells Authorized Service Agency for repairs
Element head will not raise	Frypot out of position, or has excess cooking debris in bottom	Check frypot for position Clean frypot
Element head will not stay in the up position		
Element head will not lower	Damaged hinge bracket or support rod	Contact Wells Authorized Service Agency for repairs
Basket lift will not lower	Timer not set	Set to desired cook time
	Timer red button not pushed	Push to start
	Damaged internal component	Contact Wells Authorized Service Agency for repairs
Basket lift will not raise	Damaged internal component	Contact Wells Authorized Service Agency for repairs

¹ The hi-limit safety is designed to shut down the fryer if the oil temperature exceeds 440°F. A build-up of cooking debris between the heating element and the thermobulb of the hi-limit safety will cause the hi-limit to trip prematurely. Clean the element so that oil may circulate freely between the element and the thermobulb. Reset the safety by pressing the red button on the back of the element head.

² A build-up of cooking debris between the heating element and the thermobulb temperature control thermostat will cause inconsistent temperatures. Clean the element so that oil may circulate freely between the element and the thermobulb.

MAINTENANCE SCHEDULES

USE AND MAINTENANCE SHALL BE IN ACCORDANCE WITH THE STANDARD FOR

VENTILATION CONTROL AND FIRE PROTECTION OF COMMERCIAL COOKING OPERATIONS, N.F.P.A. 17A N.F.P.A. 96 (current editions).



FAILURE TO PROPERLY CLEAN AND MAINTAIN THIS EQUIPMENT CAN CAUSE A FIRE. AN UNCONTROLLED FIRE CAN CAUSE SERIOUS INJURY, DEATH AND/OR PROPERTY LOSS.

NOTE: A signed and dated VENTILATOR HOOD MAINTENANCE LOG must be maintained on the premises, and shall be available for inspection by the authority having jurisdiction. See pages 27 and 28.

IMPORTANT: Parts used for the Ansul® fire suppression system are not serviceable by the owner / operator. Procedures for servicing fire suppression equipment are described in: ANSUL R-102 SYSTEM DESIGN, INSTALLATION, RECHARGE AND MAINTENANCE MANUAL (Ansul® #418087-05).

1. 6-MONTH MAINTENANCE (MUST BE PERFORMED BY AN AUTHORIZED ANSUL DISTRIBUTOR ONLY):
 - a. Inspect and test total operation including FIRE DAMPER and all SAFETY INTERLOCKS.
 - b. All FIRE SUPPRESSION SYSTEM actuation components including MANUAL PULL STATION and any REMOTE MANUAL PULL STATION must be inspected for proper operation in accordance with the maintenance schedule published in ANSUL R-102 SYSTEM DESIGN, INSTALLATION, RECHARGE AND MAINTENANCE MANUAL (Ansul® #418087-05).
 - c. The FIRE SUPPRESSION SYSTEM FUSIBLE LINES must be inspected. NOZZLES and MANUAL PULL STATION must be cleaned in accordance with ANSUL R-102 SYSTEM DESIGN, INSTALLATION, RECHARGE AND MAINTENANCE MANUAL (Ansul® #418087-05).
 - d. The FIRE SUPPRESSION AGENT TANK, PIPING and FLEXIBLE TUBING must be INSPECTED.
2. 12-YEAR MAINTENANCE: (MUST BE PERFORMED BY AN AUTHORIZED ANSUL DISTRIBUTOR ONLY):
 - a. The FIRE SUPPRESSION AGENT TANK and 1/2" FLEX HOSE must be HYDROSTATICALLY TESTED, and the FIRE EXTINGUISHING AGENT must be REPLACED in accordance with the maintenance schedule published in ANSUL R-102 SYSTEM (STANDARD UL 300 LISTED).
 - b. The FUSIBLE LINES in plenum and damper must be REPLACED. This maintenance to be performed by qualified Ansul service personnel only.

Inspection shall be conducted on a monthly basis in accordance with the manufacturer's Operation Manual. At a minimum, this inspection shall include verification of the following:

WELLS BLOOMFIELD, LLC
VENTILATOR HOOD OWNERS MONTHLY INSPECTION LOG

OPERATION	AGENT / DATE												
Extinguishing system components: In proper place and (visually) in good order													
Manual pull station actuators for fire suppression system are unobstructed													
The maintenance log is in place and up to date													
No obvious physical damage or condition exists that might prevent operation of the fire suppression system													
The nozzle blow-off caps are in place and in good condition													
The hood, duct and protected cooking appliance have not been replaced, modified or relocated													
Clean plenum GREASE BAFFLE and BLOWER (max. interval: 3 months)													
Change PRE-FILTER and FILTER PACK (as required)													

This MAINTENANCE LOG is to be performed and completed by a trained technician who has completed the instruction necessary to perform the maintenance and recharge service.

WELLS BLOOMFIELD, LLC
VENTILATOR HOOD MAINTENANCE LOG

OPERATION		AGENT / DATE									
Clean and inspect discharge nozzle in plenum BEFORE filters Max. interval: 6 months		/	/	/	/	/	/	/	/	/	/
Clean and inspect discharge nozzle in plenum AFTER filters Max. interval: 6 months		/	/	/	/	/	/	/	/	/	/
Inspect fire suppression fuse links, all releasing devices for actuation, fire suppressant tank liquid level Max interval: 6 months (discharge of fire suppressant not a part of this test)		/	/	/	/	/	/	/	/	/	/
Inspect fire suppression hoses, plumbing and tank for obstructions and any conditions such as, but not limited to, corrosion and pitting. Max. interval: 6 months		/	/	/	/	/	/	/	/	/	/
Inspect and test all filter interlocks Max. interval: 6 months		/	/	/	/	/	/	/	/	/	/
Replace two (2) fire suppression lines at cooling appliance: each line is rated @ 160°F Max interval: 12 months	Log TEMP	/	/	/	/	/	/	/	/	/	/
	Log Mfg DATE Stamp	/	/	/	/	/	/	/	/	/	/
Replace fire damper fusible line rated @ 280°F Max interval: 12 months	Log TEMP	/	/	/	/	/	/	/	/	/	/
	Log Mfg DATE Stamp	/	/	/	/	/	/	/	/	/	/

28

THIS MAINTENANCE LOG MUST BE KEPT IN A PROTECTIVE COVER PERMANENTLY ATTACHED TO THE APPLIANCE
 Log all repairs and recommendations on reverse side. Any repairs, other than replacement of factory authorized parts, to the fire suppression plumbing system must be subject to hydrostatic pressure testing.

IL214

ANSULEX Low pH

QUICK IDENTIFIER (In Plant Common Name)

Manufacturer's Name:	ANSUL INCORPORATED	Emergency Telephone No.:	CHEMTREC (800) 424-9300 or (703) 527-3887
Address:	One Stanton Street, Marinette, WI 54143-2542	Other Information Calls:	(715) 735-7411
Prepared By:	Safety and Health Department	Date Prepared:	February 1, 1999

SECTION 1 - IDENTITY

Common Name (Used on Label): (Trade Name and Synonyms)	ANSULEX Low pH Liquid Fire Suppressant	CAS No.:	N/A
Chemical Name:	N/A This is a Mixture	Chemical Family:	Mixture
Formula:	N/A		

SECTION 2 - INGREDIENTS

PART A - HAZARDOUS INGREDIENTS				
Principal Hazardous Component(s) (chemical and common name(s)):	Wt. %	CAS No.	ACGIH TLV	Acute Toxicity Data
None	N/A	N/A	N/A	N/A
PART B - OTHER INGREDIENTS				
Other Component(s) (chemical and common name(s)):	Wt. %	CAS No.	ACGIH TLV	Acute Toxicity Data
Proprietary Mixture of Organic and Inorganic Salts	48.0 - 50.0	N/A	N/E	NDA
Phosphoric Acid	0.2	7664-38-2	N/E	NDA
EDTA	0.65	64--02-8	N/E	NDA
Yellow-Green Fluorescent Dye	0.011	518-47-8	N/E	Oral LD ₅₀ (rat) 6800 mg/kg
Water	Approx. 50.0	7732-18-5	N/E	NDA

SECTION 3 - PHYSICAL AND CHEMICAL CHARACTERISTICS (Fire and Explosion Data)

Boiling Point:	113°C	Specific Gravity (H ₂ O=1):	1.33	Vapor Pressure (mm Hg):	Not Determined
Percent Volatile by Volume (%):	Approx. 50.0	Vapor Density: (Air = 1):	1.03	Evaporation Rate: (Butyl Acetate=1):	Approx. 0.005
Solubility in Water:	100%	Reactivity in Water:	Mild exothermic reaction		
Appearance and Odor:	Fluorescent Yellow Colored Liquid, Mild Odor				
Flash Point:	None to boiling	Flammable Limits in Air % by Volume:	N/A	Extinguisher Media:	N/A
Auto-Ignition Temperature:	N/A				
Special Fire Fighting Procedures:	NONE - THIS IS AN EXTINGUISHING AGENT				
Unusual Fire and Explosion Hazards:	None				

SECTION 4 - PHYSICAL HAZARDS

Stability:	Unstable <input type="checkbox"/> Stable <input checked="" type="checkbox"/>	Conditions to Avoid:	N/A
Incompatibility (Materials to Avoid):	Reactive Metals, ClF ₃ , electrically energized equipment, any material reactive with water.		
Hazardous Decomposition Products:	Not established, acrid fumes.		
Hazardous Polymerization:	May Occur <input type="checkbox"/> Will Not Occur <input checked="" type="checkbox"/>	Conditions to Avoid:	N/A

SECTION 5 - HEALTH HAZARDS

ANSULEX Low pH (continued)

Threshold Limit Value:	None Established		
Routes of Entry: Eye Contact:	Irritant		
Skin Contact:	Irritant		
Inhalation:	Not an expected route of entry. Can be irritating to mucous membranes.		
Ingestion:	Irritating to mucous membranes. Acute Oral LD ₅₀ (Sprague-Dawley rats) 825.5mg/kg.		
Signs and Symptoms:	Acute Exposure: Material irritates skin, eyes, and mucous membranes. Chronic Exposure: None known.		
Medical Conditions Generally Aggravated by Exposure:	None known.		
Chemical Listed as Carcinogen or Potential:	National Toxicology Program: Yes <input type="checkbox"/> No <input checked="" type="checkbox"/>	I.A.R.C. Monographs: Yes <input type="checkbox"/> No <input checked="" type="checkbox"/>	OSHA: Yes <input type="checkbox"/> No <input checked="" type="checkbox"/>

SECTION 6 - EMERGENCY AND FIRST AID PROCEDURES

Eye Contact:	Flush and irrigate with water for 15 minutes while holding eyelids open. If irritation persists, seek medical attention.
Skin Contact:	Wash thoroughly with soap and water. If irritation persists, seek medical attention.
Inhalation:	Fresh air if symptoms occur. If irritation persists, seek medical attention.
Ingestion:	Dilute by drinking large quantities of water.

SECTION 7 - SPECIAL PROTECTION INFORMATION

Respiratory Protection (Specify Type):	N/A		
Ventilation:	Local Exhaust: N/A	Mechanical (General):	N/A
Protective Gloves:	Rubber gloves for spill/leak	Eye Protection:	Chemical goggles recommended during spill/leak procedures.
Other Protective Clothing or Equipment:	Eye wash and safety showers are good safety practice.		

SECTION 8 - SPECIAL PRECAUTIONS AND SPILL/LEAK PROCEDURES

Precautions to be taken in Handling and Storage:	Store in original container. Keep tightly closed. Keep separate from acid.
Other Precautions:	See incompatibility information in Section 4.
Steps to be taken in Case Material is Released or Spilled:	Stop leaks. Contain spills. Remove as much as possible. Place in closed container for proper disposal Wash spill area with large amounts of water to remove traces and neutralize.
Waste Disposal Methods:	Dispose of in compliance with local, state and federal regulations.

HAZARDOUS MATERIAL IDENTIFICATION SYSTEM

HAZARD INDEX	
4 SEVERE HAZARD	0 HEALTH
3 SERIOUS HAZARD	
2 MODERATE HAZARD	0 FLAMMABILITY
1 SLIGHT HAZARD	
0 MINIMAL HAZARD	0 REACTIVITY

N/A = Not Applicable NDA = No Data Available N/E = Not Established
ANSUL and ANSULEX are registered trademarks.

Internet Address: <http://www.ansul.com>

PARTS BREAKDOWN for ANSUL® COMPONENTS

FOR USE ONLY BY AUTHORIZED ANSUL® SERVICE PERSONNEL

Order this Ansul part number 4808-05
 02 Restaurant Fire Suppression
 System Design Installation
 Clearing and Maintenance

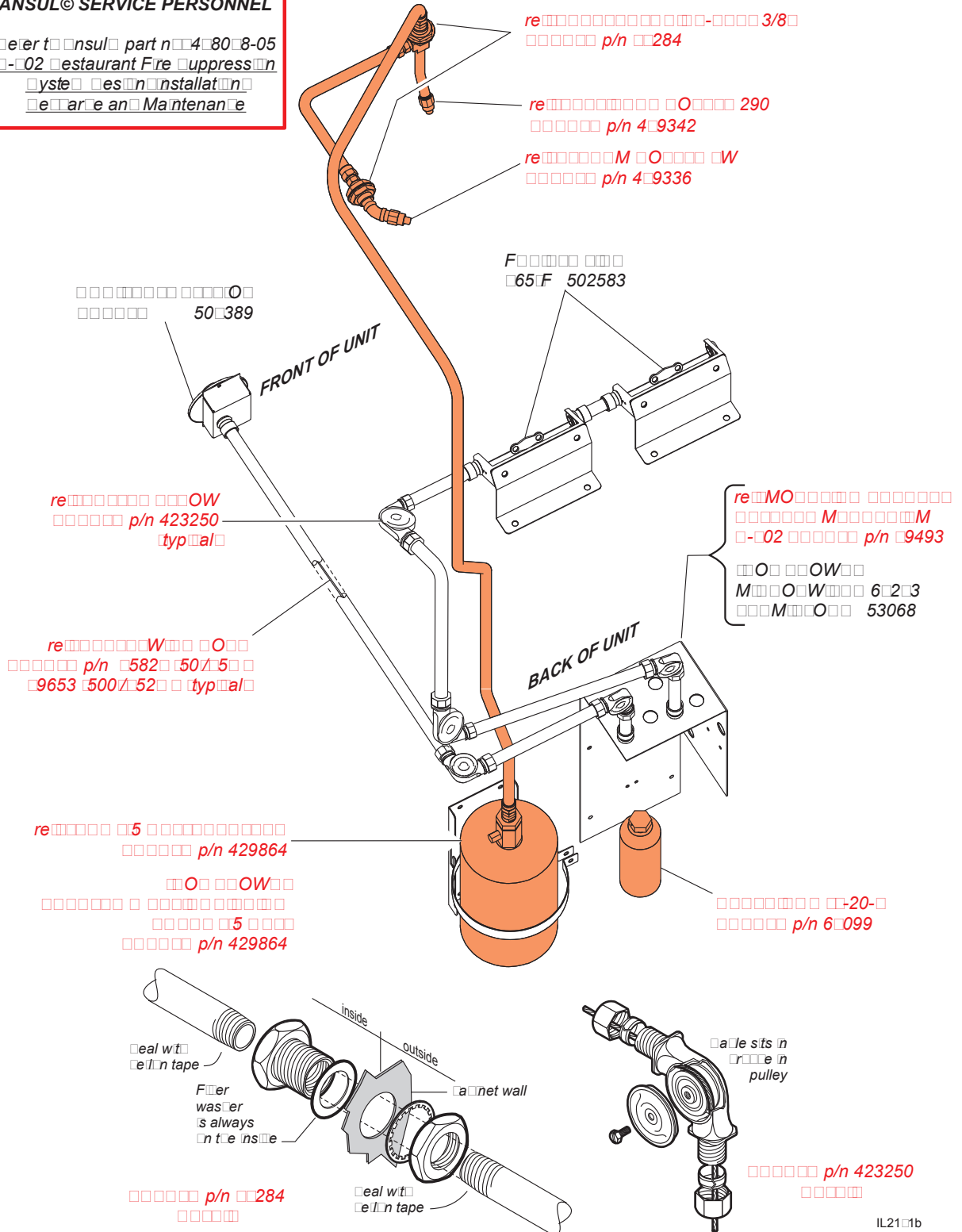

503 p/n 2M-304989 Owners Manual WVF-886 Ventless Fryer

EXPLODED VIEW & PARTS LIST

WVF886 Hood Cabinet Components			
Fig No	Part No	Qty	Description
1	2V-301187	1	Damper
2	WS-22648	Set of 2	KIT LEG REAR OPT WVF/WVG
3	5E-20804	1 Set	CASTER ASSY 2FIX 2SWVL
4	M3-302646	1	DOOR ASSY RIGHT
5	M3-302642	1	DOOR ASSY LEFT
6	2R-46502	2	MAGNET DOOR
7	M3-304405	1	TRAY GREASE DRIP HOOD
8	2Q-305099	1	GLASS GLOBE VCS HOOD
9	2S-305100	1	LIGHT BULB 100W VCS HOOD
10	2E-305098	1	LIGHT HOUSING VCS HOOD
11	2I-302580	1	FILTER BAFFEL
12	M3-302688	1	PREFILTER CAGE
13	2I-302579	1	FILTER PRE HOOD UNIVERSAL
14	WS-22619	1	FILTERPACK ASSY UNIV HOOD
15	WS-502773	2	GASKET SILICONE .25X5X18
16	WS-502772	2	GASKET SILICONE .25X5X15
17	2M-302782	1	FACEPLATE FRNT PNL UNIV

EXPLODED VIEW & PARTS LIST

WVF886 Hood Electrical & Vacuum Components			
Fig No	Part No	Qty	Description
1	2U-302584	1	BLOWER ASSY UNIVERSAL HD
2	WS-502588	1	TUBING ASSY VACUUM UNIV
3	2E-300407	2	SWITCH MANUAL ADVANCE ROT
4	2J-44834	1	BUZZER 220V ROHS
5	2J-31157	1	LIGHT SIGNAL RED
6	2J-30516	3	LIGHT SIGNAL AMBER
7	2J-35697	1	LIGHT PILOT GREEN 250V
8	2E-70395	1	SWITCH ROCKER 240V 20A
9	2E-302592	1	SWITCH VACUUM #3
10	2E-302590	1	SWITCH VACUUM #1
11	2E-302591	1	SWITCH VACUUM #2
12	2E-302593	1	SWITCH VACUUM #4
13	2K-37748X	1	FTG CONDUIT STRAIGHT 3/8
14	2E-34005	1	JUMPER FLAME SENSOR TERM
15	2E-44514	1	RELAY 208-240 COIL
16	2E-43880	1	RELAY 208/240 DPDT (RW & RWT ONLY)
17	2E-Z15704	1	CONTACTOR 75A 3 POLE
18	2K-304420	1	STRAIN RELIEF 1 1/4NPT
19	M3-303130	1	CORD SET 60AMP 3 PHASE W/PLUG
20	2Q-305099	1	GLASS GLOBE WCS HOOD
21	2S-305100	1	LIGHT BULB 100W VCS HOOD
22	2E-305098	1	LIGHT HOUSING VCS HOOD

EXPLODED VIEW & PARTS LIST

WVF886 Drawer Warmer Components			
Fig No	Part No	Qty	Description
1	WS-20624	OPTIONAL	RACK HUMITROL RWS
2	C8-46840	2	PAN INSERT DRAWER RWHD
3	WS-55487	(pk 50)	SCREW 8-32X5/16 PH (PACK OF 50)
4	2C-30471	2	CATCH IVEES MACH AS RECD
5	WS-50483	(pk 6)	BEARING ROLL WARMER SET OF 6
6	2C-35455	AR	NUT 8-32 HEX MS SS
7	2C-35565	AR	WASHER 2 1/16 DRWR BACK RWS
8	2C-35530	AR	SCREW 8-32X3/8PH RD
9	C8-49251	2	SLIDE VENT ASSY RWN
10	WS-51796	2	KNOB SQUARE ROLL WARMER VENT
11	WS-52112	2	HANDLE R W DRAWER
12	WS-67096	2	DRAWER ASY KIT RWHD
13	2T-44475	OPTIONAL	THERMOMETER RW 2 IN DIAL
14	2N-30482UL	2	ELEM 240V 450W
14	2N-30519UL	2	ELEM 120V 450W
15	C8-35677	2	BRKT ELEM MTG RW
17	WS-65923	AR	KIT REPAIR DWR STOP 6-COIL SPR
18	WS-63271	(PK 10)	CLIP RETAINER PILOT LIGHT
19	C8-307569	2	BOX OUTLET
20	2J-35687	2	LIGHT SIGNAL RED RWS
21	2T-38936	2	THERM CONT RW W/O AUX SW
22	C8-31801	1	PANEL CONTROL RW TW324
22	C8-33565	1	PANEL CONTROL LOWER RWS
23	2R-30372	2	KNOB CONTROL ASSY WARM

EXPLODED VIEW & PARTS LIST

WVF886 Auto-Lift Components			
Fig No	Part No	Qty	Description
1	WS-505656	2	BRKT LIFT ASSY F-585F
2	WS-55487	(50 PK)	SCREW 8-32X5/16 PH (PACK OF 50)
3	2V-305658	2	BLOCK PIVOT SS F-58SF
4	2A-31146	2	ROD LIFT BSKT
5	WS-50231	2	BASKER LIFT ROD SEAL-TEFLON
6	2I-30231	2	SEAL OIL TEFLON LARGE
7	WS-51145	(6 PK)	RETAINER OIL SEAL 6 PCS
8	WS-50850	2	MOTOT LIFT ASSY
9	E7-30543	2	ARM CROSS ASSY
10	E7-50879	2	ARM CRANK LEVER ASSY
11	WS-50222	(10 PK)	RETAINER RING 10 PCS
12	2D-30215	2	ARM ROCKER
13	2A-30876	4	PIN, LEVER MOTOR ASSY
14	2A-30207	4	CRANK CASTING SHORT
15	2E-30198	2	SWITCH UNIMAX
16	2K-31040	2	BUSHING HEYCO 7/8 OD
17	E7-31259	2	BRKT AUTOLIFT ROHS
18	2U-30233	2	MOTOR LIFT ELECT FRYERS
19	2A-30205	2	PIN PIVOT
20	WS-51048	(10 PK)	SCREWS (SERV) 8-32X3/8 RD PCK

EXPLODED VIEW & PARTS LIST

WVF886 Fryer Head Components

Fig No	Part No	Qty	Description
1	WS-62926	2	HEAD ASSEMBLY F88-6 208V STS
	WS-62927		HEAD ASSEMBLY F88-6 240V STS
2	2R-37882	2	KNOB CONTRL ASSY AUTOFRY
3	WS-55510	2	THERMO CTRL FRYER KP-715
4	2C-30157	AR	CLIP CAPILLARY
5	WS-62504	(4 PK)	CLAMP BULB SAFTEY PK OF 4
6	2N-42842UL	2	ELEM 208V 5750W
7	2N-42866UL	2	ELEM 240V 5750W
7	2R-30211	2	HANDLE LIFT GRAY
8	2K-33358	2	ADAPTER HANDLE F58, 68, 88
9	2P-34452	2	CAP PUSH ON TYPE BASKET
10	2A-32427	2	ROD SUPPORT SHORT HEAD
11	2P-32428	2	SPRING SUPPORT ROD
12	WS-55566	(100 PK)	SCREWS(SERV)6X1/4 TH SS
13	E7-35028	2	COVER CONTROL BOX WO/SAF
14	2I-55747	4	GASKET DRWR RWS CLOSED CE
15	E7-30464	2	BOX CONTROL ASSY F5585
16	WS-58656	2	THERMO HI-LIMIT MAIN RESET
17	2J-31157	2	LIGHT SIGNAL RED
18	2J-30516	2	LIGHT SIGNAL AMBER 240V
19	2C-30172	4	NUT 7/8-14 HEX
20	WS-50176	(10 PK)	WASHER LOCK 7/8 FRYER ELEM PK10
21	2I-Z12311	4	GASKET -FIBER WASHER

EXPLODED VIEW & PARTS LIST

FRYER CABINET COMPONENTS

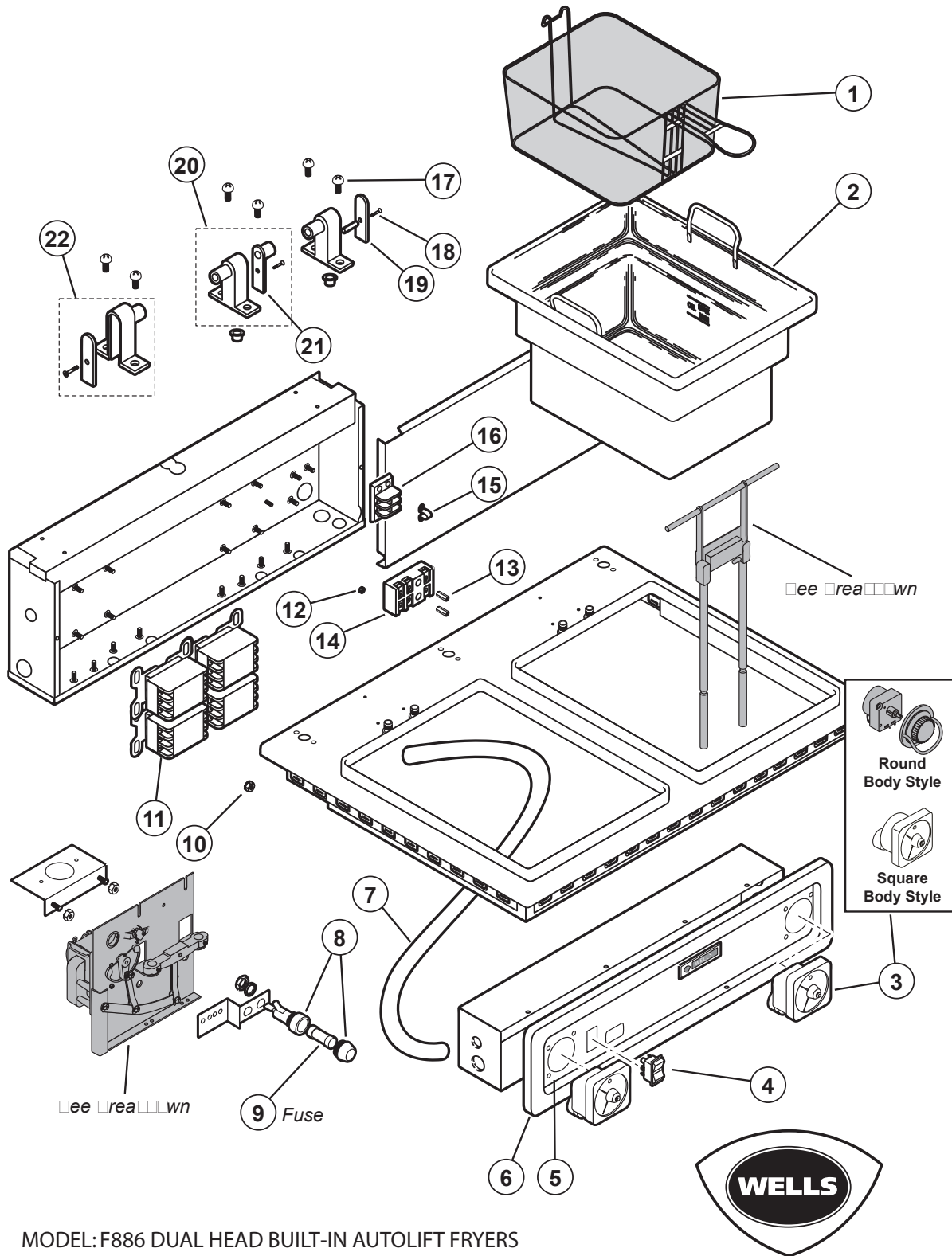

MODEL: F886 DUAL HEAD BUILT-IN AUTOLIFT FRYERS



EXPLODED VIEW & PARTS LIST

WVF886 Fryer Cabinet Components				
Fig No	Part No	Qty	Description	Application
1	2B-43688	AR	BASKET 1/2 SIZE	
	2B-43689		BASKET FULL SIZE	
2	E7-301344	2	POT ASSY F SERIES FRYER	
3	PS-WL0153	1	KIT, TIMER 40MIN 240V DPST	Round Body Style
	PS-WL0148	2		Square Body Style
	PS-WL0152	1		
	PS-WL0151	2		
4	2E-35127	1	SWITCH ROCK PLAS BEZEL	
5	2M-308072	1	FACEPLATE VCS F886 STS	
6	E7-308069	1	CONTROL PANEL VCS F886	
7	WS-51881	3 FT	SLEEVING VARGLAS 3' LONG	
8	2E-34769	1	FUSEHLDR HPG-EE 10A 240V	
9	2E-34768	1	FUSE SC-10, 10A 300V	
10	2C-31053	AR	NUT 8-32 KEPS MS NICKEL	
11	WS-57779	4	CONTACTOR 3POLE 208V 40A	
11	WS-57780	4	CONTACTOR 3POLE 240V 40A	
12	2C-35736	AR	NUT 8-32 HEX KEPS MS	
13	2C-41974	AR	NUT 8-32 HEX 7/8 LONG ALU	
14	WS-50131	1	TERM BLOCK KIT	
15	2E-34005	1	JUMPER FLAME SENSOR TERM	
16	WS-53068	1	TERM BLOCK 2 POLE	
17	2C-33890	AR	SCREW 12-24X3/4PH PAN	
18	2C-31717	AR	SCREW 8X32X7/8 PH FL ROLO	
19	2A-32806	2	COVER PIVOT BRKT TUMBLED	
20	WS-53895	1	CENTER PIVOT BRKT ASSY	
21	H6-33245	1	COVER PIVOT DBL TUMBLE	
22	WS-50183	2	HINGE BRACKET END	

WIRING DIAGRAM

WVF-886 HOOD SECTION WIRING DIAGRAM

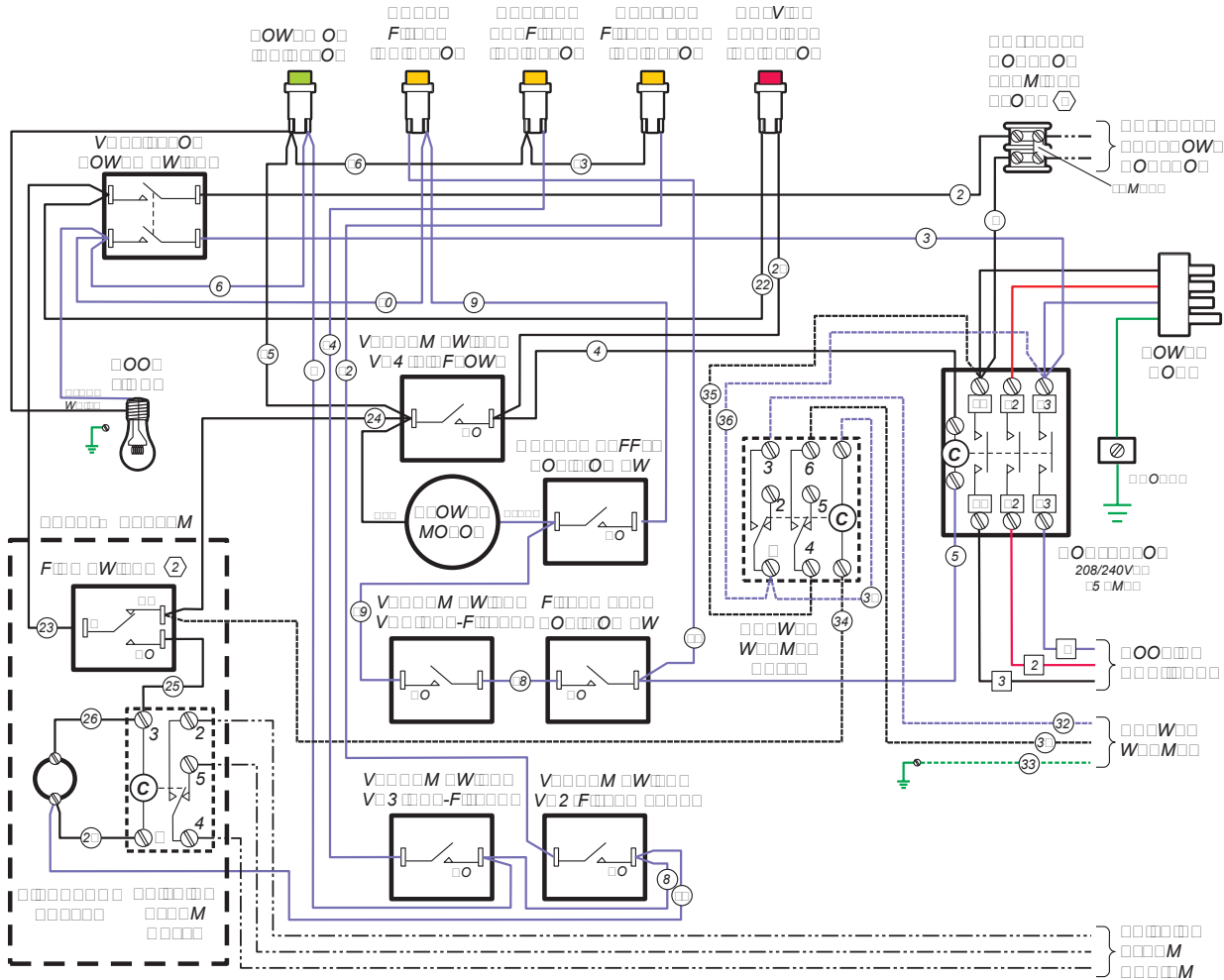

NOTES

- 1 MOV M W
 - 2 F W W
 - 3 M
 - 4 M
- IMPORTANT:**
- 5 O O O O W O
 - 6 O O O O M O

MODEL	VOLTS 60Hz	3ø AMPS			1ø AMPS	WATTS
		L1	L2	L3		
WVF-886	208/240	33	33	33	15	1500
WVF-886	208/240	33	33	33	15	1500

part n 2M-302802 issue

WIRING DIAGRAM

WVF-886 FRYER SECTION WIRING DIAGRAM

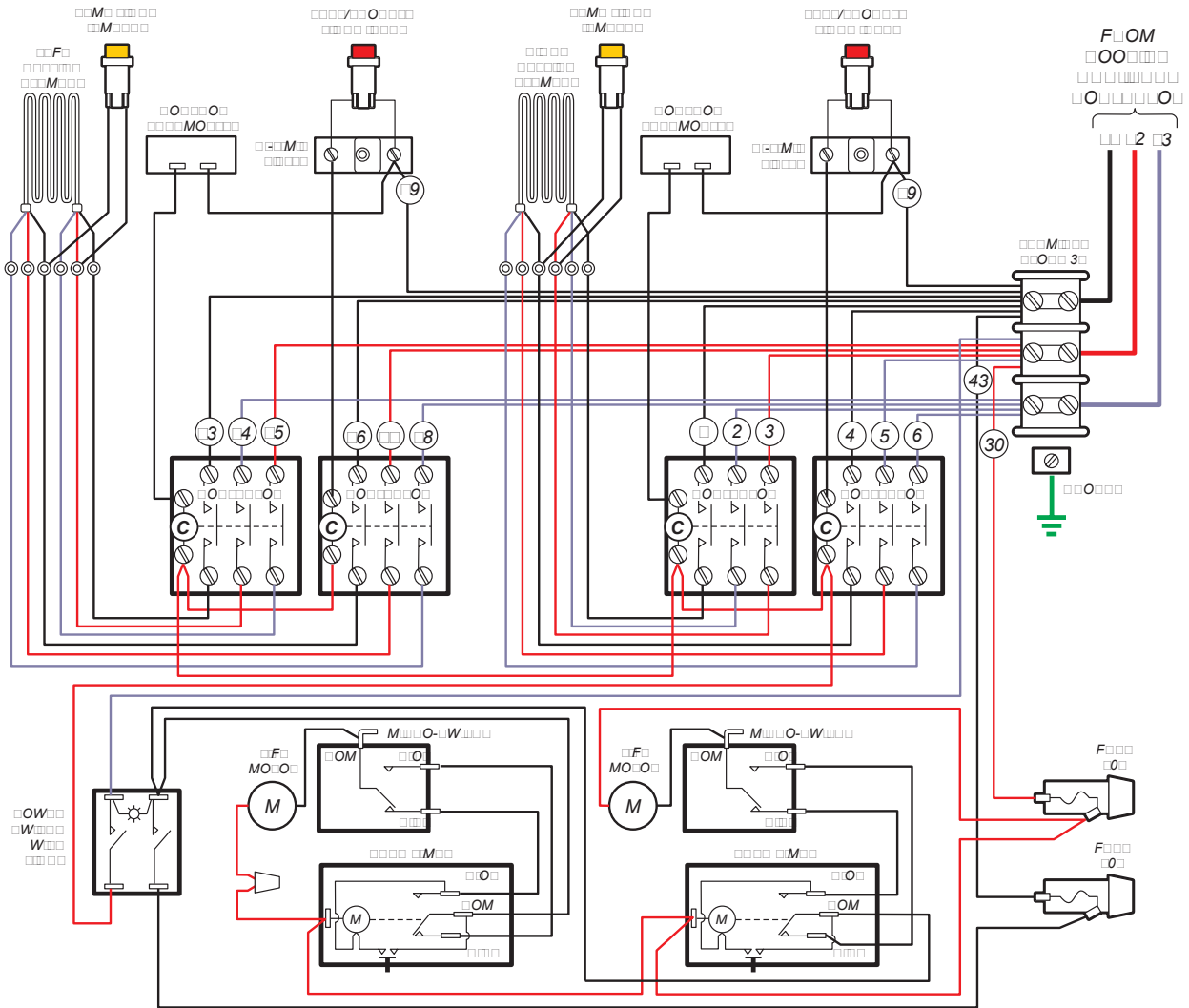

WVF-886 Fryer Section
 part number 2M-3050

WIRING DIAGRAM

WVF-886RW DRAWER WARMER SECTION WIRING DIAGRAM

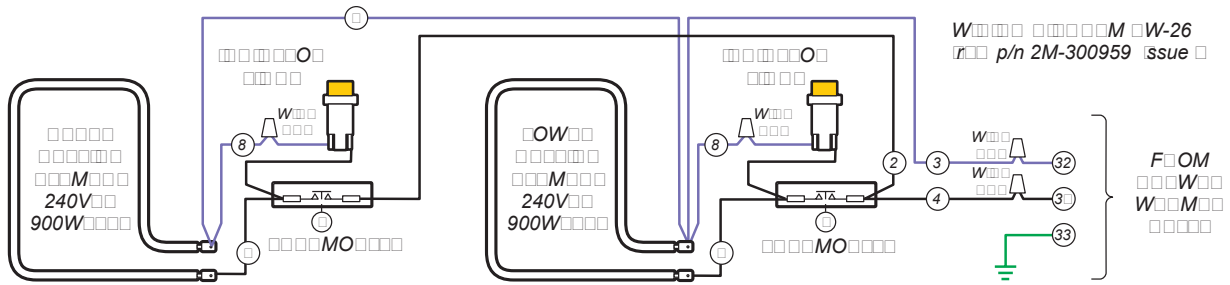

WVF-886RWT DRAWER WARMER SECTION WIRING DIAGRAM

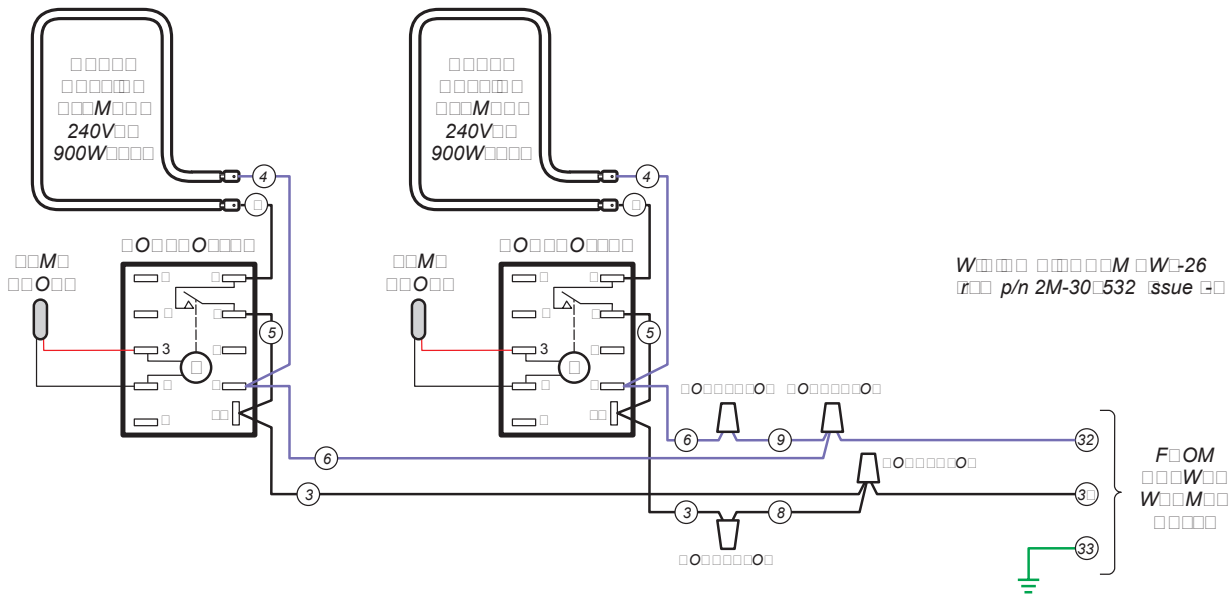







Wells Bloomfield proudly supports CFESA
Commercial Food Equipment Service Association

SERVICE TRAINING - QUALITY SERVICE



CUSTOMER SATISFACTION



WELLS BLOOMFIELD, LLC

11000 Wells Blvd. Bloomfield, NJ 07003

908-841-3333

908-841-3333

www.wells.com | info@wells.com