



Project \_\_\_\_\_

Item # \_\_\_\_\_

Quantity \_\_\_\_\_

# SPECTRUM Electric Countertop Conveyor Toaster

Model: ECT-300 (300 slices per hour)  
ECT-700 (700 slices per hour)

The SPECTRUM CONVEYOR TOASTER is the ideal choice for serving perfectly toasted breads, bagels, small pizzas and similar dough-based products. This easy-to-operate unit can keep pace with even the busiest kitchens and buffets. The belt-speed dial allows control over doneness, and the top & bottom heating elements can be on simultaneously or independently.

The specially designed return ramp is rounded, extra-wide and ideal for over-sized bagels. Features an easy-load rack, front return chute, as well as optional rear product return.

### Standard Features

- ◆ Heavy duty all stainless steel "Cool-Touch" exterior
- ◆ Large 2-1/2" (64 mm) high feeder opening with a 10-3/8" (264mm) (2 slice) wide conveyor accepts over-sized bagels and Texas Toast
- ◆ Rounded, extra-wide curved return chute prevents larger foods items from getting caught
- ◆ Variable conveyor-speed dial control for optimal doneness
- ◆ Choose between independent or dual-heating elements for added flexibility
- ◆ Energy Saver-Hold mode saves up to 75 percent energy during slow periods when unit is not in use and allows quick recovery to temperature.
- ◆ Removable crumb tray
- ◆ Adjustable legs with non-skid foot add stability
- ◆ One year parts and labor warranty

### Accessories and Options

ECT300-P8	120V NEMA 5-20P Cord & Plug (Required for Canada)
ECT-SK	Stacking Kit
BGS-1	Bagel Slicer
SPBR-604	Butter Roller
TWP-31	Sandwich Spreader
TWP-31P	Sandwich Spreader, Purple, Allergen-Free
SCPH-33	Condiment Packet Holder



ECT-500  
ECT-700



ECT-SK

**For California Customers**  
 **WARNING:** Cancer and Reproductive Harm - [www.P65Warnings.ca.gov](http://www.P65Warnings.ca.gov)

Winco®, DWL International Trading, LLC

[www.wincous.com](http://www.wincous.com) | [equipsales@wincous.com](mailto:equipsales@wincous.com)

**New Jersey Headquarters:**  
65 Industrial Road, Lodi, NJ 07644  
Tel. 1.888.946.2682 | Fax: 1.888.946.2632

**California Distribution Center**  
14950-14952 Valley View Avenue, La Mirada, CA 90638  
Tel. 1.888.946.2652 | Fax: 1.562.926.5678

**Florida Distribution Center**  
10800 NW 103rd St. Bldg 22, Ste 11, Miami, FL 33178  
Tel. 1.786.536.4656



## Electric Countertop Conveyor Toaster

Models: ECT-300 | ECT-700

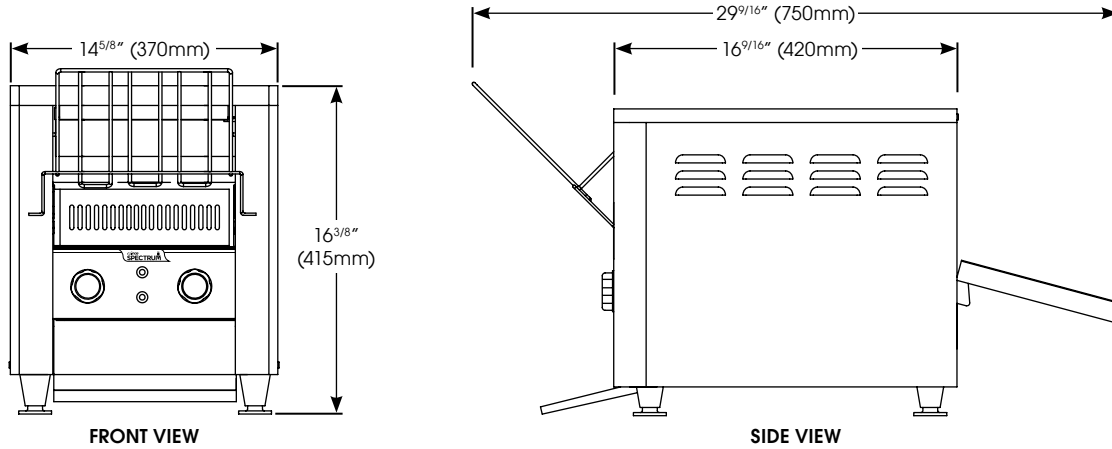

MODEL	DESCRIPTION	OVERALL DIMENSIONS			VOLTS	HZ	WATTS	AMPS	PLUG	SHIP WEIGHT
		LENGTH	DEPTH	HEIGHT						
ECT-300	Slices per Hour 300	14-5/8" (370mm)	16-9/16" (420mm)	16-3/8" (415mm)	120	50/60	1800W	15	NEMA 5-15P NEMA 5-20P* (Canada)	44.53 lbs (20.2 kgs)
ECT-700	Slices per Hour 700				208/240	50/60	1800/2400	8.6/10	NEMA 6-15P	

\* NEMA 5-20P Cord/Plug set is required for Canada (sold separately)

**CAUTION:** Risk of fire and electric shock. Replace only with manufacturer's cord set, part no.: SJTO (14AWG x 3C)

**ATTENTION:** Risque d'incendie et de cho électrique. Remplacez uniquement avec le cordon série du fabricant, une partie nombre: SJTO (14AWG x 3C)

### Cord Location

Bottom of unit on left side

### Plug Configurations

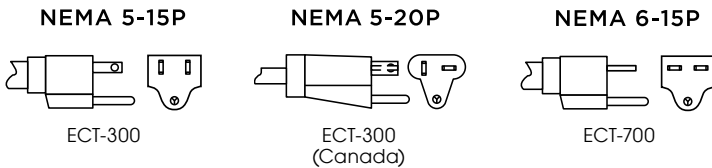

### Product Specs

#### Electric Countertop Conveyor Toaster

The Electric Countertop Conveyor Toaster models ECT-300 and ECT-700 as manufactured by Winco®, Lodi, NJ 07644

The Electric Countertop Conveyor Toaster model ECT-300 model shall have the capacity to toast up to 300 slices per hour and shall be rated at 1800 Watts, 120V~50/60Hz/1 and supplied with a NEMA 5-15P (NEMA 5-20P Canada) plug and model ECT-700 shall have the capacity to toast up to 700 slices per hour and shall be rated at 1800/2400 Watts, 208/240V~50/60Hz/1 and supplied with a NEMA 6-15P plug. Units shall be constructed of stainless steel with a cool-touch exterior and be equipped with a large 2-1/2" (64mm) high feeder opening with a 10-3/8" (264) (2 slice) wide conveyor, rounded extra-wide curved return chute, variable conveyor-speed dial control for optimal doneness, independent or dual-heating elements control, energy saver-hold mode, removable crumb tray, and adjustable legs with non-skid foot.

ETL listed for safety (Canada & US) and sanitation.

Warranty consists of one year parts and labor.

Winco®, DWL International Trading, LLC

www.wincous.com | equipsales@wincous.com

**New Jersey Headquarters:**  
65 Industrial Road, Lodi, NJ 07644  
Tel. 1.888.946.2682 | Fax: 1.888.946.2632

**California Distribution Center**  
14950-14952 Valley View Avenue, La Mirada, CA 90638  
Tel. 1.888.946.2652 | Fax: 1.562.926.5678

**Florida Distribution Center**  
10800 NW 103rd St. Bldg 22, Ste 11, Miami, FL 33178  
Tel. 1.786.536.4656