



# Intek Steamer model XSG-5

## Model Numbers

XSG-5

## Description

The Intek XSG connectionless countertop steamer unit has a pan capacity of 5 pans (2.5" deep 12" x 20"). Unit must be capable of producing steam at 212°F with no water or drain connection required. Unit is to have inverted convection fan technology and includes a 1 year parts and labor warranty. NSF listed as both steamer and holding cabinet. UL listed.

## Standard Features

- 14 gauge reinforced stainless steel cavity - fully insulated
- Two panel door with rugged 14 gauge stainless steel outer door
- Heavy refrigeration style door handle with magnetic latch
- Removable stainless steel wire racks positioned to support 1", 2.5", 4", or 6" deep pans
- Inverted flow forced convection technology
- Magnetic door switch turns off convection fan when door is open
- Front mounted water reservoir drain valve
- 60,000 BTU/hr high-efficiency powered infrared gas burner with boilerless heating system
- 60-minute electro-mechanical timer, 2-position ON/OFF selector switch, indicator lights for COOK, STANDBY, HEAT and LOW WATER
- Low water warning system with automatic shut-down control
- 4" adjustable stainless steel legs with flanged feet
- UL-Gas, NSF Listed

## Gas

- 1/2" NPT
- 60,000 BTU/hr
- Supply Pressure:  
Natural- 5.00" WC minimum, 14.00" WC maximum  
Propane- 10.00" WC minimum, 14.00" WC maximum
- Manufacturer must be notified if installed above 2,000 ft. altitude

## Electrical

- 115 VAC, 1 Phase, 5 amp

Model XSG-5



## Options/Accessories

- Stand w/Bullet Feet for Single or Double Stack
- Casters for Stand
- Flanged Feet for Stand
- Door Hinged Left
- Correction Package
- Auto Water Fill
- Drain Line
- Double-Stacked Chimney Kit
- Gas Quick-Disconnect Kit for Stand with Casters

## Origin of Manufacture

Steamer shall be designed and manufactured in the United States.

**5 Pan Capacity  
Stainless Steel  
Pressureless,  
Connectionless Steamer**

**Table Top  
Self-Contained  
Gas Heated**

## Short Form

Groen Intek XSG 5-pan connectionless countertop steamer unit has 60,000 BTU/hr high-efficiency powered infrared gas boilerless heating system. Heavy-duty 14 gauge stainless steel cooking compartment and door. Easy-open heavy duty magnetic door latch. Convection fan with inverted flow technology. Standard control features include: 60-minute electro-mechanical Timer, ON/OFF selector switch and indicating lights. 4" stainless steel adjustable legs with flanged feet. Unit includes a 1 year parts and labor warranty. Unit to be NSF and UL listed and manufactured in the U.S.A.



## Applications

Pasta  
Rice  
Vegetables (Fresh & Frozen)  
Seafood (Fresh & Frozen)  
Poultry  
Potatoes  
Eggs  
Meats  
Reheat Cook-Chill & Prepared Foods

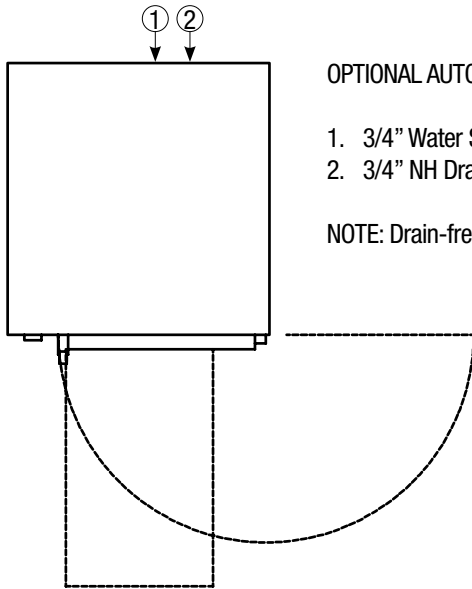

OPTIONAL AUTO WATER FILL CONNECTIONS:

1. 3/4" Water Supply Hose Connection
2. 3/4" NH Drain Connection

NOTE: Drain-free venting, do not connect directly to drain. Allow 2" air gap.

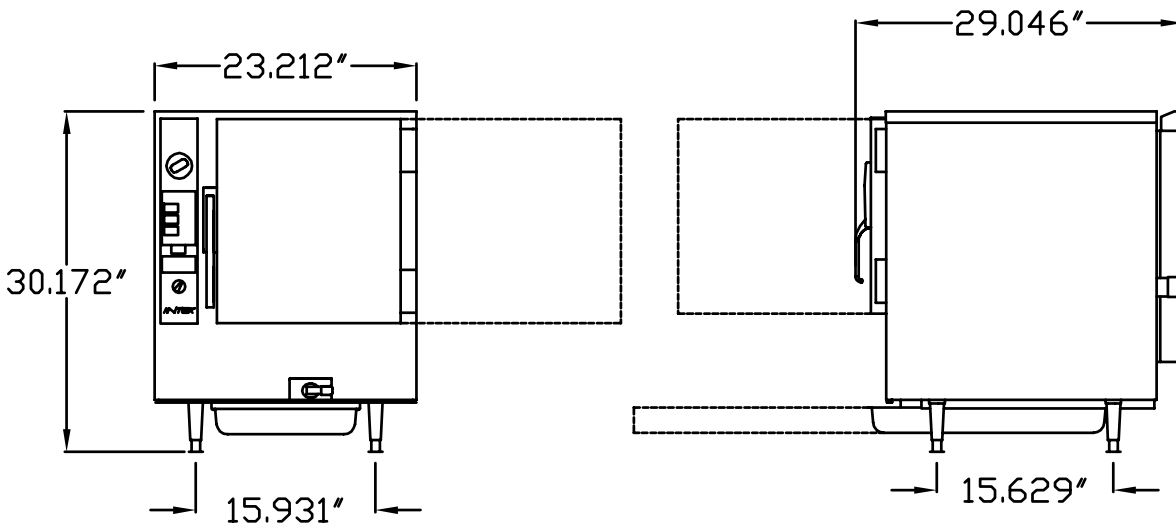

Model No.	No. of Pans	Voltage	KW/hr	NEMA	Width IN	Depth IN	Height* IN	Weight LBS
XSG-1	5	120/60/1	.6	5-15P	23-1/4"	29"	30-1/4"	270
170944	STAND W/BULLET FEET, FOR SINGLE OR DOUBLE				27"	32.5"	47"	62

\*Optional stands are 27" w x 32.5" d x 47" h, 62 lbs. Overall height of unit installed on a single stand is 60.25". Overall height of units installed on a double stand is 71.5".

**XSG SINGLE AND  
DOUBLE STACKED  
UNITS**

Stands shown with optional casters.  
Stands standard with bullet feet.

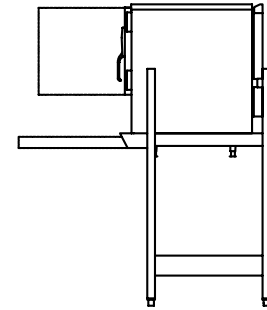
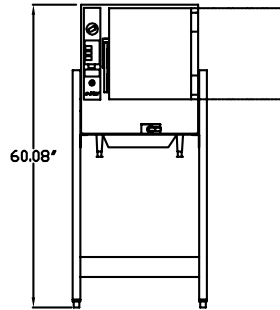
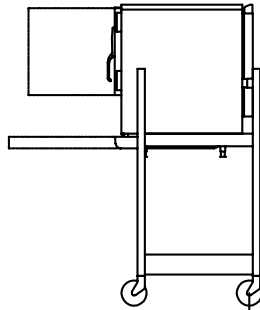
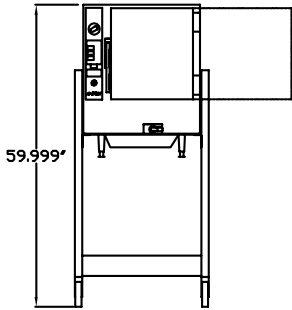
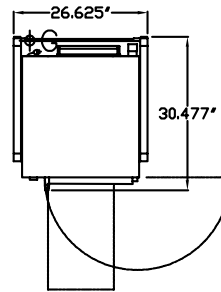
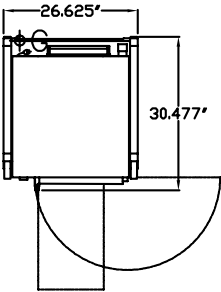

**XSG ON 10CA**

**XSG ON 10NC**

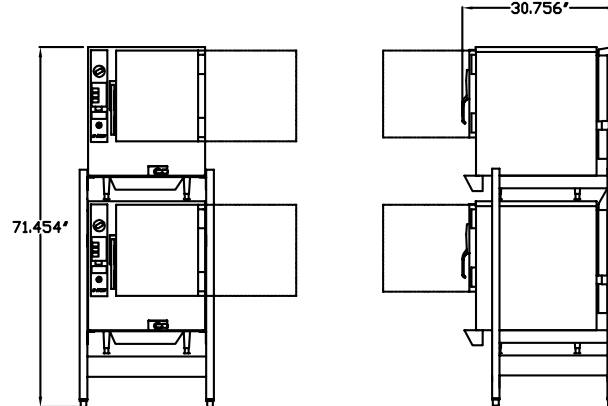
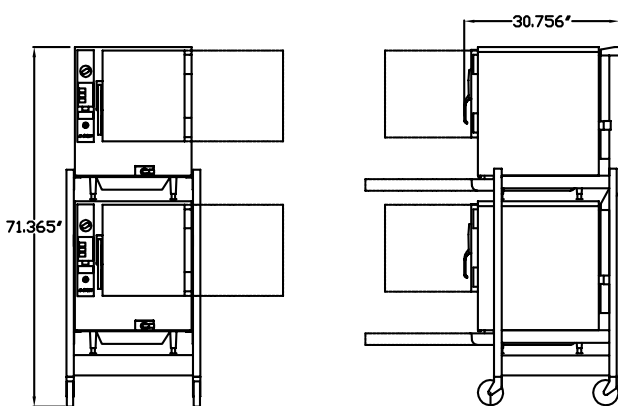

**XSG ON 20CA**

**XSG ON 20NC**

