

PRODUCT:

QUANTITY:

Models  W-9iSP  W-9iSP2  W-9iSP3  
ITEM:

## Designed Smart

Merchandise a variety of soups and/or sauces in the new 1/3 multi-well warmer. Separate well controls allow you the flexibility to heat and hold as needed. Wrapped with a "Hot Delicious Soup" decal, this merchandiser will catch attention from a distance.

## Standard Features

- Supplied with Hi-Temp pan inserts for dry-well operation
- Designed to be ran dry (without water) but can be ran wet (with water).
- 3 Sizes available – 1-1/3 pan, 2-1/3 pan or 3-1/3 pan
- Manual thermostat with pilot light
- Constructed of 430 Stainless Wrapper, 304 Stainless Well Pan.
- Hi-temp wiring
- Bulb and Capillary thermostat or Digitally controlled with thermocouple
- Insulated well, sides & bottom

## Optional Features:

- Cup & Lid Holder
- Pans
- Ladles



## Reliability Backed by APW Wyott's Warranty

All APW Wyott Warmers are backed by a 1 year parts and labor warranty.

Certified by the following agencies:



PRODUCT:

QUANTITY:

Models  W-9iSP  W-9iSP2  W-9iSP3  
ITEM:

## Product Specifications

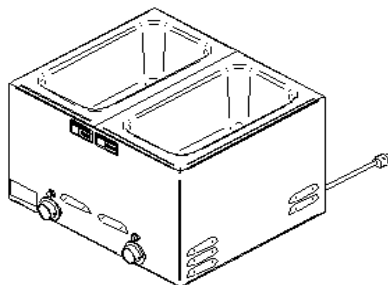
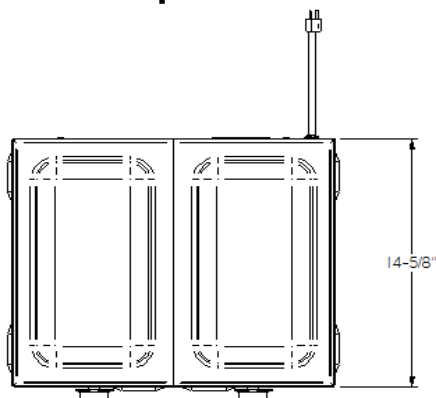

Models  W-9iSP  W-9iSP2  W-9iSP3

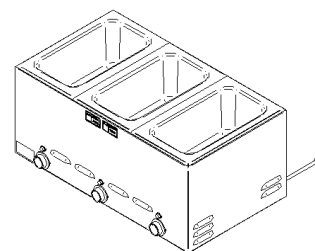
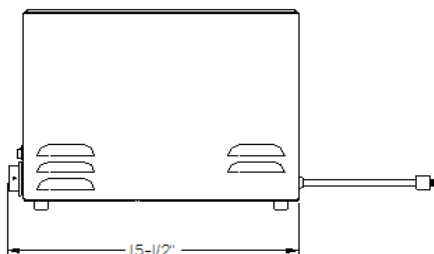
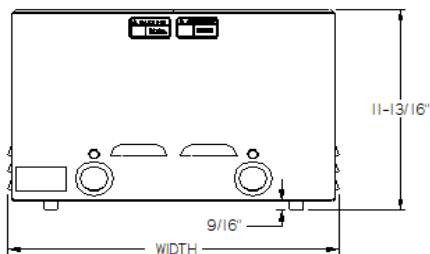
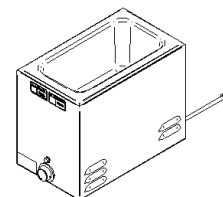

Model	Width	Height	Depth	Lbs
W-9iSP	9"	11-13/16"	14-5/8"	25
W-9iSP2	17-5/8"	11-13/16"	14-5/8"	40
W-9iSP3	30.25"	11-13-16"	14-5/8"	55

### Dimension Notes:

Depth & Height the same for all models, only width varies. Only 2-well version shown for clarity.

### Construction / Operation:

Stainless steel well pans and housing thermostatically controlled. When operating in Dry condition (no water in well) Hi-Temp (325F ) pan inserts must be used.

### Electrical Information:

Each unit is equipped with at least a 66", three wire grounded power cord, which terminates with a standard three-pronged male plug. The U.S. 120V units utilize a NEMA 5-15P plug.

### Electrical Specifications:

Model	Amps	Volts	Watts
W-9iSP	3	120	350
W-9iSP2	6	120	700
W-9iSP3	9	120	1050

\*APW Wyott reserves the right to modify specifications or discontinue models without incurring obligation.