

B-446 BUILT-IN CHAR BROILER

B-446 BUILT-IN CHAR BROILER

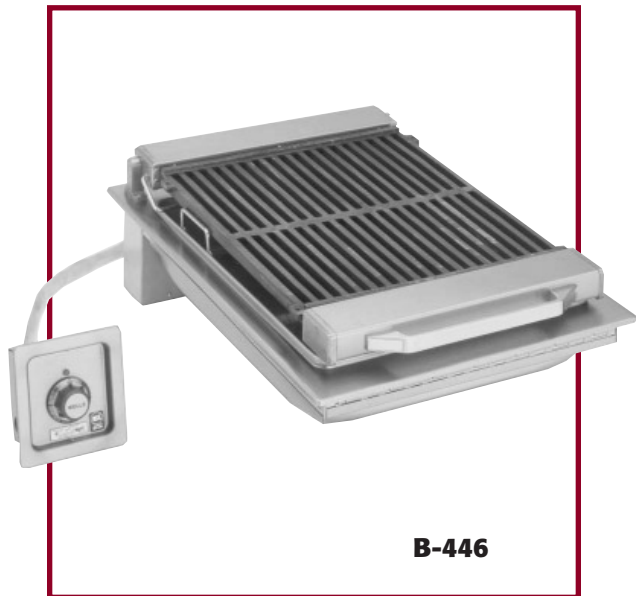

Wells B-446 Built-In Char Broiler has a stainless steel top that makes it one of the most durable in the industry. Self-cleaning elements are protected by the heavy-duty cast-iron grate and provide dual heating action, using both conductive and radiant heat.

Features

- **The self-cleaning elements** are positioned between the broiler grate ribs to guard against direct food contact and spatula abrasion. The elements also provide dual heating action (conductive and radiant).
- **Temperature** is regulated by an infinite control with a positive-off position and a signal light to indicate a power-on condition.
- **Element frame assembly** has a spring-loaded support rod to secure element when in a raised position.
- **Lift-out, drawn drip pan with handles** and removable **cast iron grate** allows fast and easy cleaning.
- **Control knob** is recessed in a one-piece, drawn, stainless steel panel to help prevent accidental temperature changes.
- **A terminal block** is provided for field connection to the main power supply.
- Each unit is provided with a **grate scraper/brush**.
- **The B-446 Broiler** is Underwriters Laboratories, Inc. Recognized and meets NSF International standards.
- **A one-year warranty** against defects covers parts and labor.

Specifications

Overall Dimensions:	Inches	MM
Width	19 7/16	494
Depth	29 9/16	751
Grid Surface Dimensions:		
Width	16	406
Depth	20	508
Area	320 in ²	.21 m ²
Temperature Settings:	OFF/LO to HI	
Number of Controls:	1	
Pre-Heat Time to 600° F:	10 minutes	
Typical Production:	Per Load	Per Hour
Hamburgers	25	350
Steaks	9	80
Weights:	Lbs.	KG
Installed	69	31
Shipping	80	36





**MODEL
B-446
BUILT-IN CHAR BROILER**

DIMENSIONS: INCH
 (MM)

MINIMUM CLEARANCE REQUIRED FROM UNIT TO THE NEAREST SURFACE			
BACK	SIDE	BOTTOM	FRONT
$\frac{7}{8}$ (178)	$\frac{6}{8}$ (152)	$\frac{3}{8}$ (76)	$\frac{5}{8}$ (16)

NOTE: Depending on the installation, clearances can be reduced upon further evaluations to UL standards.

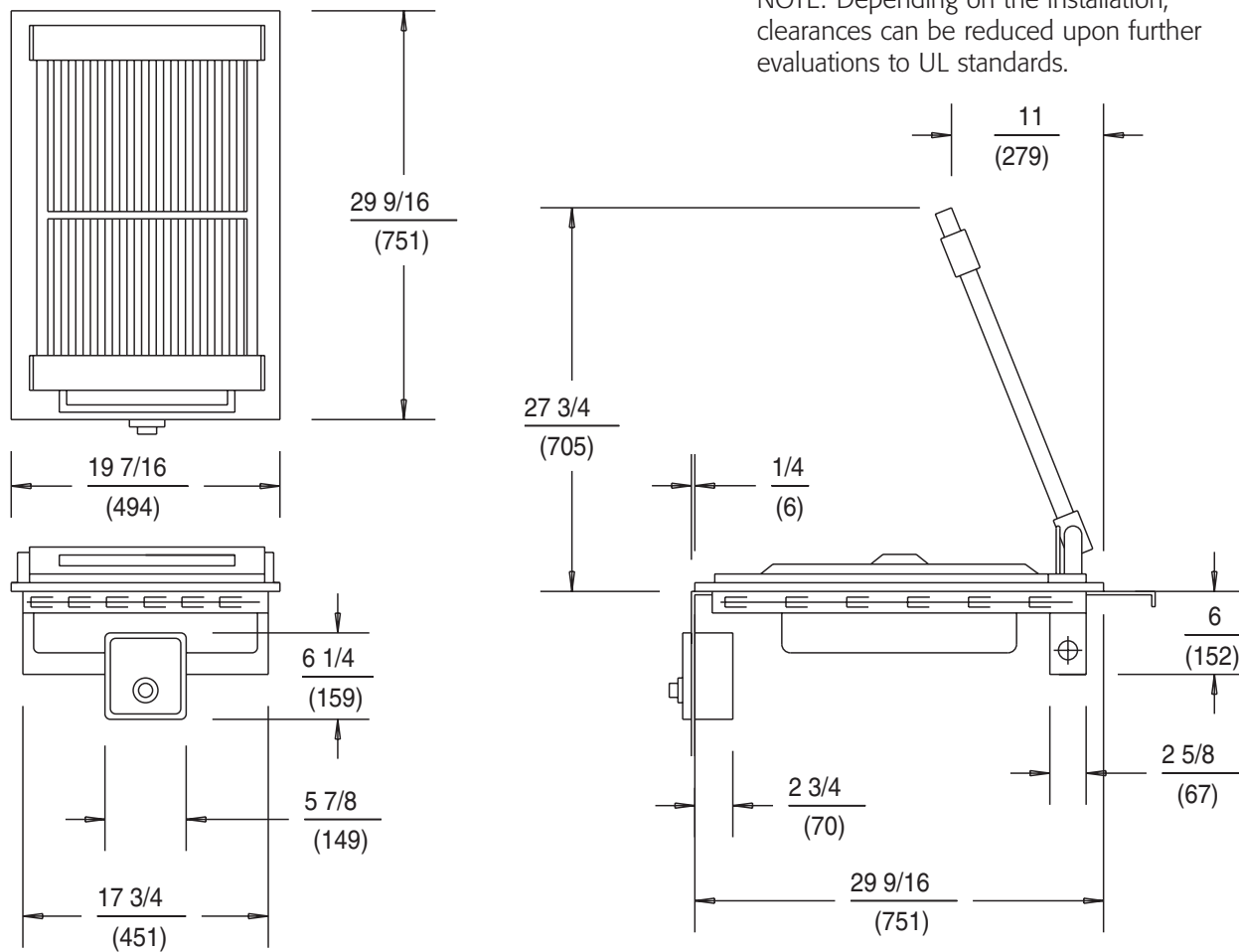

B-446 ELECTRICAL SPECIFICATIONS:

MODELS	VOLTS	WATTS	AMPS PER LINE PHASE 3			AMPS SINGLE PHASE	POWER SUPPLY CORD
			L1	L2	L3		
B-446	208	5400	11.5	22.4	14.4	26.0	NONE
B-446	240	5400	10.0	19.5	12.2	22.5	NONE

NOTE: Specifications are subject to change without notice. See installation instructions prior to installing the unit. This document is not for installation purposes. The installation of recognized component units requires additional evaluations to Underwriters Laboratories, Inc. standards.

THIS UNIT IS DESIGNED TO BE INSTALLED IN METAL COUNTERS ONLY.

WELLS MANUFACTURING COMPANY
2 ERIK CIRCLE, PO BOX 280, VERDI, NV 89439 U.S.A. • USA PHONE: (775) 689-5700 • FAX: (775) 689-5972
FOR ORDERS ONLY: (888) 356-5362 • FAX: (800) 356-5142 • www.wellsbloomfield.com
© 2001 WELLS MANUFACTURING • PRINTED IN THE U.S.A. • 04/01 • REV(F) • PART NO. 38885

