



BEVERAGE-AIR

Project: _____
 Item: _____
 Location: _____
 Approved: _____

AIA#

SIS#

FOOD PREPARATION TABLES

DPD60HC Deli/Pizza Prep Table with Two Drawers
 Hydrocarbon Series

MODEL:
 DPD60HC-2



3 Year Parts/Labor Warranty
Additional 4 Year Compressor Warranty

CABINET CONSTRUCTION

- Stainless steel front, sides, top, drawers and grille (galvanized back & bottom)
- Interior liner is made of corrosion resistant aluminum
- Aluminum top interior liner prevents spill from falling into cabinet
- Stainless steel top
- Removable hoods and insulated lid assemblies are made of matching stainless steel
- Magnetic gaskets provide positive seal on drawers
- 3" Casters, 2 with brakes standard
- 19" Wide reversible cutting board is removable for easy cleaning
- Units will accept pans up to 6" deep (pans are not included)
- Drawer frames are heavy-duty stainless steel
- 12-Gauge stainless steel drawer slides with Delrin® rollers rated at 275 lbs
- Telescoping slides, with locking mechanism to prevent drawers from being pulled off of cabinet
- Heavy-duty pan locking divider supports are standard in drawers
- Compressor available on left or right, specify at time of unit order

OPTIONS & ACCESSORIES

- Stainless steel back
- Stainless steel interior
- Clear lid
- Overshelf kits
- Pan support
- Composite cutting board
- Thermometer
- Night cover
- 6" Legs black or seismic/flanged
- Remote option* (see note on back page)

REFRIGERATION SYSTEM

- Uses environmentally friendly, energy efficient R290 refrigerant, and meets all regulatory requirements for CARB, SNAP, DOE & more
- Adaptive defrost
- Epoxy coated evaporator coil
- Enhanced airflow maintains temperatures between 36° - 38°F

DPD60HC FOOD PREPARATION : DELI/PIZZA PREP SERIES



Please verify qualifying units by visiting:
www.energystar.gov/cfs

3779 Champion Blvd., Winston-Salem, NC 27105
 1-888-845-9800 Fax: 1-336-245-6453
 Beverage-Air.com Sales@bevair.com



BEVERAGE-AIR

MODEL	DPD60HC-2
EXTERNAL DIMENSIONAL DATA	
Width Overall	60"
Depth Overall with Cutting Board	37"
Height Overall with 3" Casters with Lid Open	53 1/4"
No. of Drawers	2
Depth with Drawer Open 90°	55"
Drawer Openings	40 1/2" x 10 7/8"
Depth, Cutting Board	19"
INTERNAL DIMENSIONAL DATA	
NET Capacity (cubic ft.)	17.0
Internal Width Overall (in)	56"
Internal Width Usable (in)	41"
Internal Depth Overall (in)	26"
Internal Height Overall (in)	23 3/4"
ELECTRICAL DATA	
Full Load Amperes	4.5
REFRIGERATION DATA	
Horsepower	1/2
Capacity (BTU/Hr)	2940
Heat Rejection (BTU/Hr)	4410
Charge (lbs/grams)	0.231/105
SHIPPING DATA	
Gross Weight - Crated	514 lbs
Height - Crated	48"
Width - Crated	69"
Depth - Crated	37"

*NOTE: Remote units are field wired and come with 6" legs. Refrigerant must be specified at time of order.

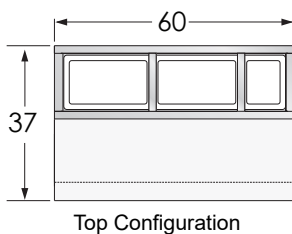

Deli/Pizza Preparation Table with Drawers Model: DPD60HC-2

Model Views

Required Clearance: Rear 2"

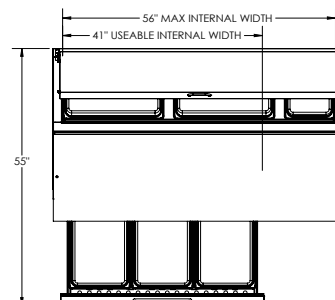

PLAN VIEW

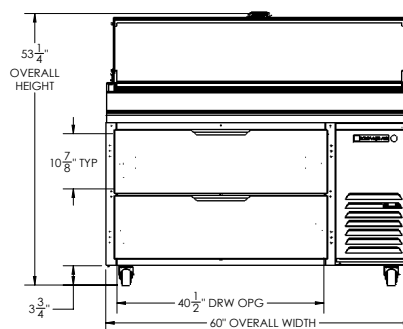

ELEVATION VIEW

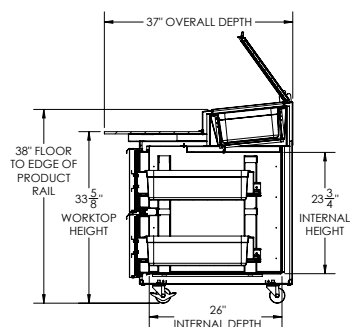

SIDE VIEW

ELECTRICAL CONNECTION



115/60/1
NEMA 5-15P

Unit pre-wired at factory and include 8' long cord and plug set.



3779 Champion Blvd., Winston-Salem, NC 27105 1-888-845-9800 Fax: 1-336-245-6453 Beverage-Air.com Sales@beva.com

an Ali Group Company



The Spirit of Excellence