



# Cyclone SERIES

Job \_\_\_\_\_ Item # \_\_\_\_\_

## GAS CONVECTION OVENS



- Model BCO-G1 Single
- Model BCO-G2 Double



**Model BCO-G1  
with optional casters**

### STANDARD FEATURES

- Energy efficient 60,000 BTUH oven combination direct/indirect forced air heat system in natural or LP gas
- 120v, 60hz controls
- Electronic temperature control
- Double-pane thermal glass door windows
- Oven lights
- 60-Minute continuous ring timer with manual shut-off
- 150°F (65°C) to 550°F (288°C) temperature range
- 1/4 HP air-cooled two-speed fan motor
- Cool down fan mode
- Burners-on and temperature-ready indicator lights
- Porcelain enamel oven interior
- 11-Position removable rack guide with 1 5/8" spacing
- 5 Heavy-duty, positive-stop, chrome-plated wire racks
- Stainless steel front, top & sides
- Black Powder Coated legs with adjustable bullet feet
- Stainless steel, 60/40 split independent operation doors, with dual mounted handles
- Stainless steel door seals
- Stacking kit for double ovens
- Front mounted, hinged control panel for easy service access
- Heavy-duty industrial grade insulation in top, sides, back & doors
- Limited 1-year parts, labor & door warranty

### SPECIFICATIONS

Full-size gas, forced air, single and double deck convection type oven. Standard specifications include 60,000 BTUH per deck, a two-speed fan with cool down and our patented wheel-within-a-wheel enhanced air flow system powered by an energy saving 1/4 HP air cooled fan motor.

Door interlock switch automatically turns the fan and burners off when the oven door is open. A manual rotary switch will turn the fan on when the door is open for quick cool-down. The 60 minute timer has a continuous ring alarm with manual shut-off. The indicator light glows when the burners are on.

The oven interior measures 29" wide (737mm) by 20" high (508mm) by 22 1/4" deep (567mm). The cooking chamber is porcelain enamel over heavy gauge steel with removable 11-position rack guides with 1 5/8" spacing (41mm) and 5 heavy-duty adjustable chrome-plated racks.

The oven exterior measures 39" wide (991mm) by 39" deep without handles (991mm) and 41 3/8" deep with handles (1051mm) by 32" (813mm) high. Front, top, sides and trim are constructed with stainless steel. Single oven legs are 31 3/8" tall (797mm) casters and 27 5/8" (702mm) with adjustable bullet feet finished with Durable Black Powder Coating.

Dual doors are 60/40 split-type with double-pane thermal glass, independent operation, stainless steel seals and double mounted "Cool Touch" handles. Doors are fabricated with stainless steel inside-and-out, and fully insulated with 2" of industrial grade insulation.

### OPTIONS & ACCESSORIES

- Open rack stand with rack supports
- Black Powder coated legs with stainless steel undershelf
- Additional oven racks
- Heavy-duty caster set, two with caster locks
- Perforated rear panel - field installation only
- Oven flue
- Stainless steel legs with or without casters
- LP gas
- International voltages, 50hz

### CERTIFICATIONS



BAKERS PRIDE OVEN COMPANY, INC.  
30 Pine Street, New Rochelle, NY 10801  
914/576-0200 • 1-800-431-2745 • fax 914/576-0605  
www.bakerspride.com

*Continuous product improvement is a policy of Bakers Pride Oven Company. Therefore, specifications and design are subject to change without notification*

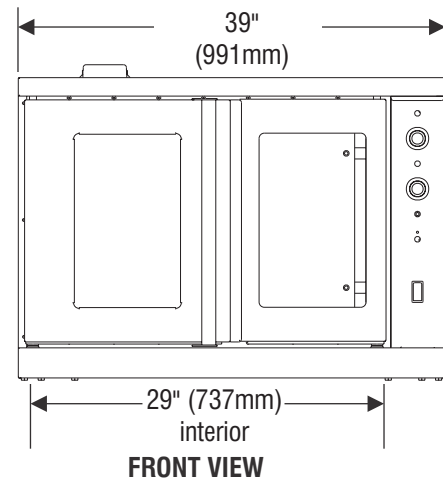
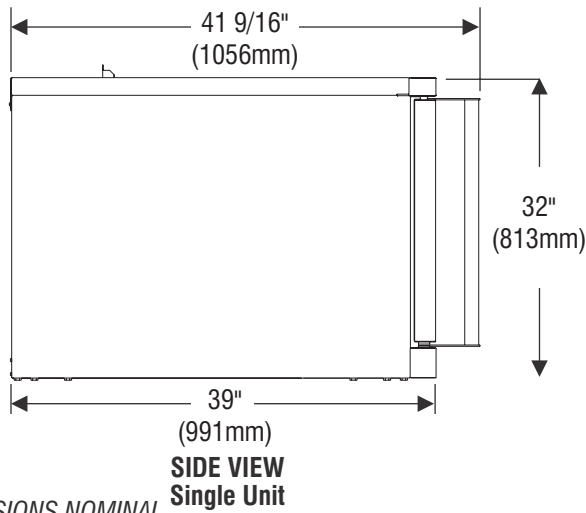
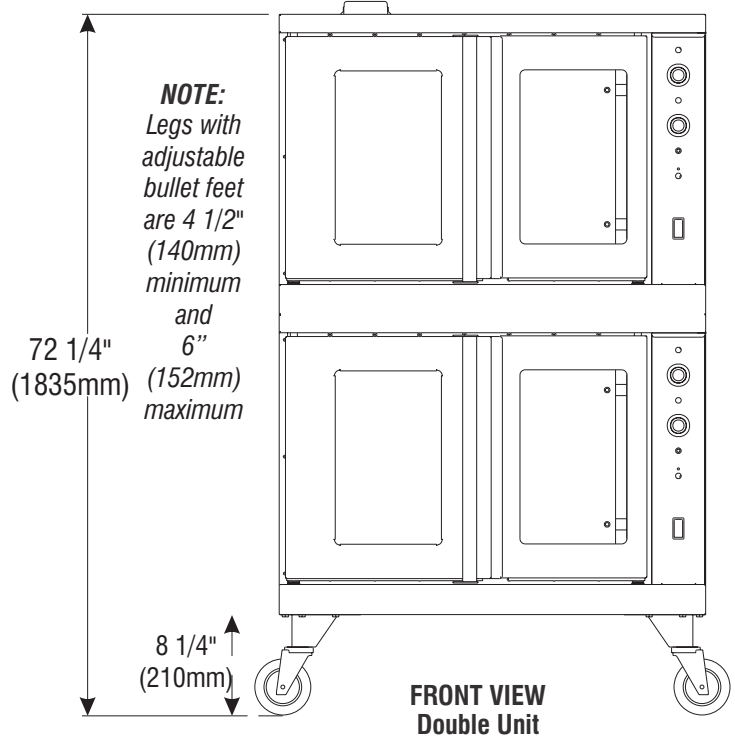
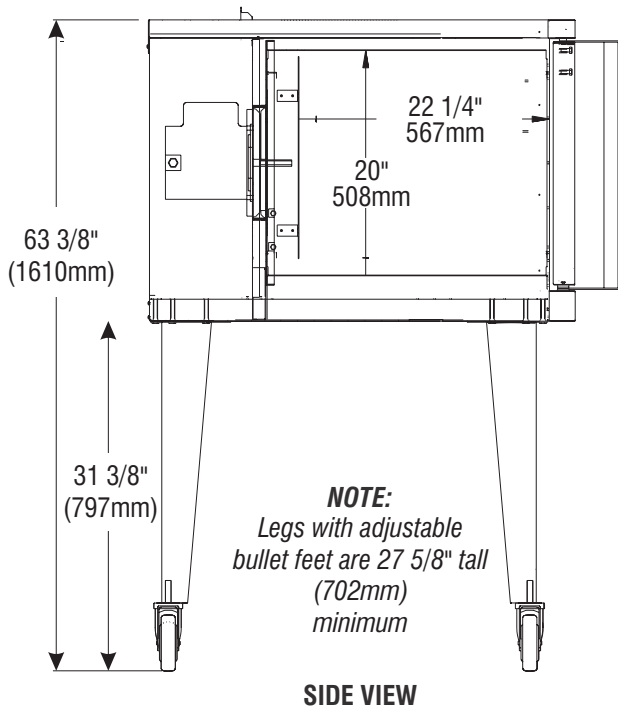

ALL DIMENSIONS NOMINAL

Model	Shipping Weight		Carton Size		Carton Dimensions					
	Lbs.	Kilos	Cubic Feet	Cubic Meters	Width		Depth		Height	
					Inches	mm	Inches	mm	Inches	mm
BCO-G1	565	256	39.25	1.11	43	1092	48 1/4	1226	38 1/4	972
BCO-G2	DOUBLE Shipped in two cartons as per above specifications									

Gas Type	Manifold Pressure		Inlet Pressure	
	WC	Mbar	WC	Mbar
Natural	3.5"	9 min	7"	17.5 min
Propane	10"	25 max	11"	27.0 min

Separate gas connections or external manifold required for stacked ovens

Model	POWER SUPPLY								
	BTUH	KW	HZ	Voltage 1Ø	Amps	Wire	Phase	RPM-low	RPM-high
BCO-G1	60,000	17.58	60	120	3.5	2	1	900	1,725

Separate gas and electric connections required for stacked ovens

	Vent Hood		Direct Venting	
	Inches	mm	Inches	mm
Right	1	25	1	25
Left	1	25	3	76
Rear	3	76	3	76

Suitable for installation on combustible floors when installed on factory supplied legs or casters



BAKERS PRIDE OVEN COMPANY, INC.  
30 Pine Street, New Rochelle, NY 10801  
914/576-0200 • 1-800-431-2745 • fax 914/576-0605  
www.bakerspride.com

Continuous product improvement is a policy of Bakers Pride Oven Company. Therefore, specifications and design are subject to change without notification TSW:08/06