



The New Symbol of Innovation

# Three Solid Full Door Freezer



**CFD-3F**  
72 cu.ft., 3 section

Stainless steel interior & exterior standard!  
Fully-recessed handles  
Tray slide shelving system  
Exterior digital temperature controls

**STANDARD FEATURES:**

- Capillary tube
- CFC-free R-404a Refrigerant
- 4 Epoxy-Coated Wire Shelves per Section
- Snap-In Magnetic Door Gaskets
- Tray Slide Shelving System
- 5" Casters
- Foamed-in-place Polyurethane Insulation
- Fully Covered Interior Corners
- Interior Light
- Door Locks
- Bottom-Mount Compressor & Evaporator Coil
- Hot Gas Condensate Evaporator
- Exterior Digital Temperature Control
- Self-closing Doors with Hold Open Feature
- Assembled in the USA

**MATERIALS:**

INTERIOR: 304 series stainless steel interior for durability and appearance.  
Epoxy-coated wire shelves.

EXTERIOR: Stainless steel cabinet and doors.



**DIMENSIONAL DATA:**

Model No.	L	D	H	Cu.Ft.	Shelves	H/P	Volt	Amp.	NEMA	Ship Wt.
CFD-1F	29.0	32.3	82.5	23	4	1/2	115/60/1	9.6	5-20P	380
CFD-2F	54.0	32.3	82.5	48	8	3/4	115/60/1	12.4	5-20P	560
<b>CFD-3F</b>	<b>81.0</b>	<b>32.3</b>	<b>82.5</b>	<b>72</b>	<b>12</b>	<b>1</b>	<b>220/60/1</b>	<b>9.9</b>	<b>6-15P</b>	<b>760</b>
CFD-1R	29.0	32.3	82.5	23	4	1/3	115/60/1	6.3	5-20P	360
CFD-2R	54.0	32.3	82.5	48	8	1/2	115/60/1	8.7	5-20P	540
CFD-3R	81.0	32.3	82.5	72	12	1/2	115/60/1	9.4	5-20P	730



Refrigeration Equipment Manufacturer

## Solid Door Freezer

# CFD-3F

Description: Three solid full door freezer, 72 cu. ft

### Features & Benefits

**Stainless steel interior and exterior for greater durability, construction and appearance.**

Self-contained bottom mounted refrigeration system and high humidity coated **fin coil** evaporator.

- Holds -10° F to 10° F as freezer

Automatic interior light.

Exterior LED temperature display with digital controls. **Temperature setting is easy, fast and accurate.**

Micro-controller with adjustable temperature variance, automatic defrost intervals, setpoint limits, and parameter locking functions.

2.5" thick, foamed-in-place polyurethane high density insulation.

12 adjustable epoxy-coated steel wire shelves. Built-in tray slides to accommodate shelves (standard) or 18"x26" sheet pans (optional).

5" casters standard. **Easy mobility and installation.**

Heavy-duty overall construction for high-volume, constant duty operation.

Self-closing doors with 90° hold open feature. **Door locks** standard.

Hot gas condensate evaporator - **no floor drain required!**

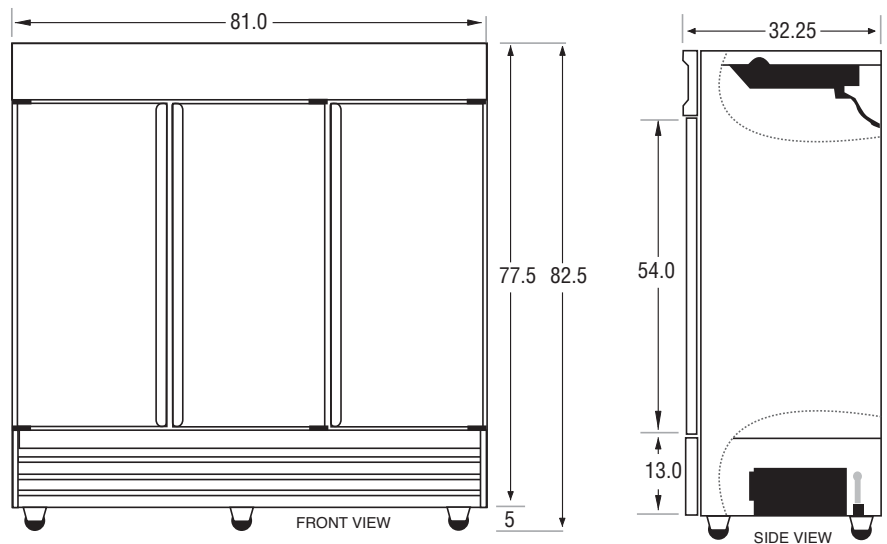
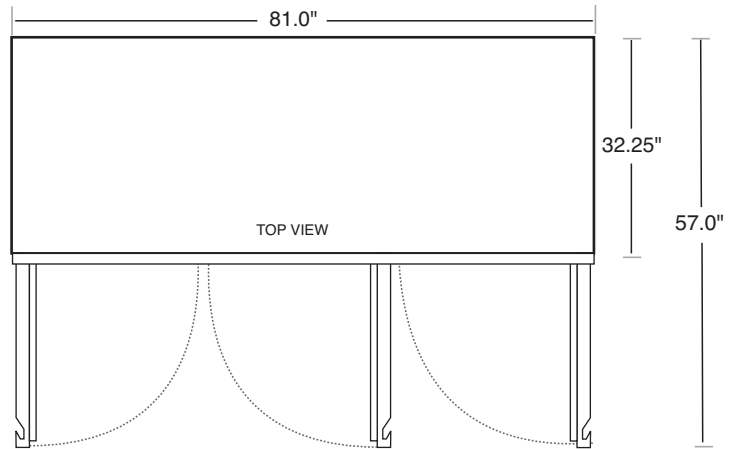

### OPTIONS

- |                          |                            |            |
|--------------------------|----------------------------|------------|
| <input type="checkbox"/> | Extra Interior Shelves     | Qty. _____ |
| <input type="checkbox"/> | Extra Shelf Slide Brackets | Qty. _____ |
| <input type="checkbox"/> | Tray Slide Brackets        | Qty. _____ |

### General Information

**Cubic Ft.:** 72

**Doors:** 3

**Exterior:** Stainless

**Interior:** Stainless

**Shelf Size:** 25.5" x 21"(x8) 25.5 x 23"(x4)

**Unit Weight:** 690 lbs.

**Ship Weight:** 760 lbs.

### Technical Data

**Refrigerant:** R-404a

**Start Amps:** 14.9

**Run Amps:** 9.9

**Horsepower:** 1

**Volts:** 220

**#Compressors:** 1

**Cord Length:** 75 in.

SPECIFICATIONS SUBJECT TO CHANGE WITHOUT NOTICE