



Conserver[®] XL HH

Project _____
 Item _____
 Quantity _____
 CSI Section 11400
 Approval _____
 Date _____

Conserver[®] XL HH

Models

Conserver[®] XL HH



Standard Features

- Electromechanical timer
- Internal sump design
- Built-in waste accumulator
- 3" (76 mm) stainless steel adjustable bullet feet
- Delimer switch for easy removal of hard water deposits
- Removable scrap screen
- Air gap instead of vacuum breaker
- Door switch
- Convenient top mounted controls
- Auto start
- Interchangeable upper and lower stainless steel wash/rinse arms
- Wash thermometer
- Low product indicator light

Mandatory Specs

Specify voltage _____

Options

- Water Hammer Arrestor
- Scaltrol
- False Panel
- Flanged Feet
- Audible Low Product Alarm

Accessories

- 36-Compartment Rack
 - 4-1/8" tall (105 mm)
 - 5-5/8" tall (143 mm)
 - 7" tall (178 mm)
- Combination Rack
- Peg Rack

Specifications

Uses 1.61 gallons (6.09 liters) water per rack

39 racks per hour (Normal cycle)

Single point electrical connection

Self-draining stainless steel pump eliminates soil/detergent carryover between wash and rinse cycles

Dump and fill feature disposes of dirty water, replacing it with a fresh water rinse every cycle

Field convertible from straight to corner and corner to straight for flexible installations and applications

27" (685.8 mm) vertical inside clearance

Built-in chemical pumps and priming switches

Large removable scrap screen

Heavy duty stainless steel construction





Conserver® XL HH

Legend:

- E1: Main Electrical Connection (1-1/8" DIA Hole)
- W: Main Inlet Water Connection (1/2" NPT - Female)
- D: Drain Connection (2" NPT - Male)
- DET: Detergent Bulkhead Access (7/8" DIA Hole)
- SAN: Sanitizer Inlet
- RA: Rinse Aid Inlet

ALL DIMENSIONS ARE ±1/2"

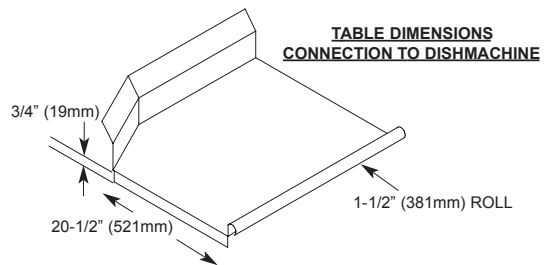
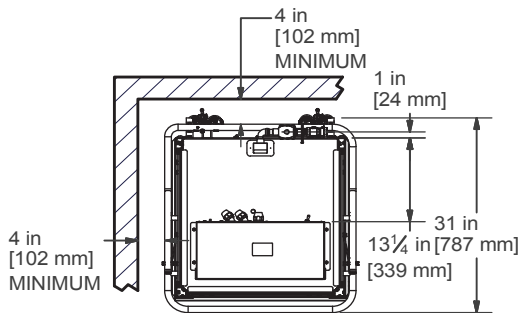
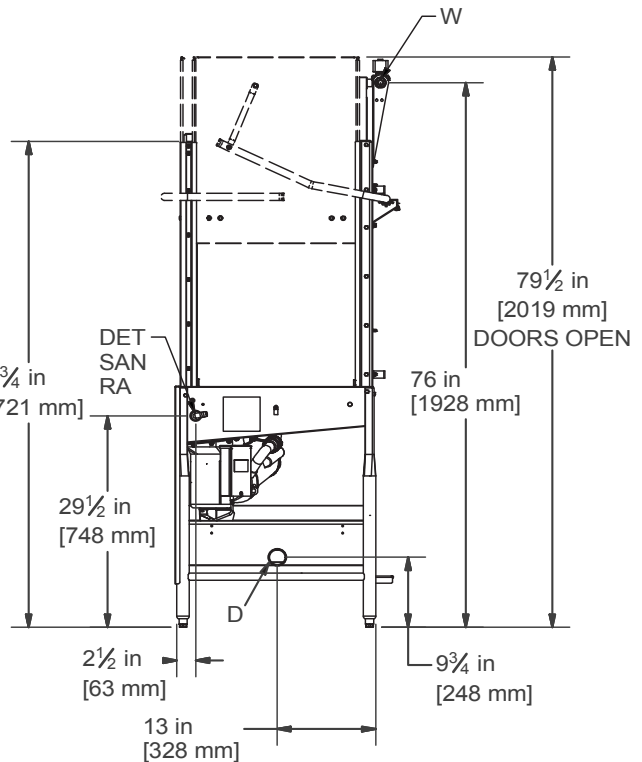
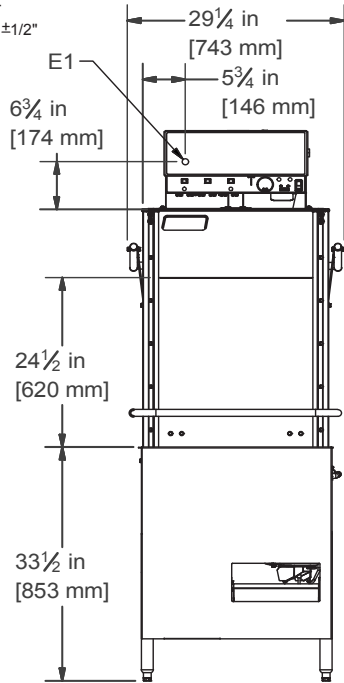

MODEL NO.	MACHINE DIMENSIONS				DRAIN HEIGHT	SHIPPING INFORMATION					
	HEIGHT	WIDTH	WIDTH BETWEEN DISHTABLES	DEPTH		WEIGHT	CLASS	CUBE	HEIGHT	WIDTH	DEPTH
Conserver® XL HH	79" (2007 mm)	30-3/8" (772 mm)	25-1/4" (641 mm)	29-1/2" (749 mm)	9-3/4" (248 mm)	300 lbs (136 kg)	92.5	64.9 cu. ft.	83" (2108 mm)	33" (838 mm)	43" (1092 mm)

POWER REQUIREMENTS	
Electrical Requirement	115V/60HZ/1PH - 11.4A
Service Breaker Size	15A

PERFORMANCE CAPABILITIES	
Flow Pressure (PSI)	20
Wash Pump Motor Horsepower	3/4
Pump Capacity (GPM)	55
Minimum Chlorine Required (PPM)	50

WATER REQUIREMENTS		
	MINIMUM	RECOMMENDED
Inlet Temperature	120°F (49 °C)	140°F (60 °C)
Wash Operating Temperature	120°F (49 °C)	140°F (60 °C)
Rinse Operating Temperature	120°F (49 °C)	140°F (60 °C)

HOW TO SPECIFY: Conserver® XL HH

Jackson WWS, Inc.

Shipping Address: 6209 North U.S. Highway 25E, Gray, KY 40734
 Mailing Address: P.O.Box 1060, Barbourville, KY 40906
 Telephone: 888-800-5672 • Fax: 606-523-1799
 Email: info@jacksonwws.com
 07610-004-27-61 [10/07/15]

www.jacksonwws.com

We reserve the right to change specifications in this bulletin without incurring any obligation for equipment previously or subsequently sold.