



STAINLESS STEEL
Glass Rack Storage Units
21" Wide Units

Item #: _____ Qty #: _____
Model #: _____
Project #: _____



CRCR-24-CT Shown
Holds Up To 3 Glass Racks

FEATURES:

- Enclosed base case with glass rack slides.
- Holds up to three glass racks.
- Flat or corrugated tops available.
- Drain located in back right of top (corrugated top model only).
- 3" diameter drain hole in back panel for plumbing.
- Stainless steel legs with adjustable stainless steel bullet feet.
- 4" backsplash.

MATERIAL:

- 20 gauge, 300 stainless steel
- Backsplash:** 22 gauge, 300 stainless steel
- Glass Rack Slides:** 18 gauge, 300 stainless steel
- Drainboard:** 22 gauge, 300 stainless steel (CRCR-24-CT only)
- Legs:** 1 5/8" O.D. 16 gauge, stainless steel with adjustable plastic bullet feet

MECHANICAL:

- 1" IPS drain

Model #	Description	Size W x L x H	Btm. Drain Location	Glass Rack Capacity*	Approx. Weight	Approx. Cu. Ft.
CRCR-24	Flat Top	21" x 24" x 33"	N/A	3	52 lbs.	13
CRCR-24-CT	Corrugated Top	21" x 24" x 33"	11 1/2"	3	52 lbs.	13

**Sizes Of Glass Racks Vary*



Customer Service Available To Assist You 1-800-645-3166 8:30 am - 8:00 pm E.S.T.

For Orders & Customer Service:
 Email: customer@advancetabco.com or Fax: 631-242-6900

For Smart Fabrication™ Quotes:
 Email: smartfab@advancetabco.com or Fax: 631-586-2933

DIMENSIONS and SPECIFICATIONS

TOL Overall: $\pm .500''$ Interior: $\pm .250''$

ALL DIMENSIONS ARE TYPICAL

CRCR-24/ CRCR-24-CT

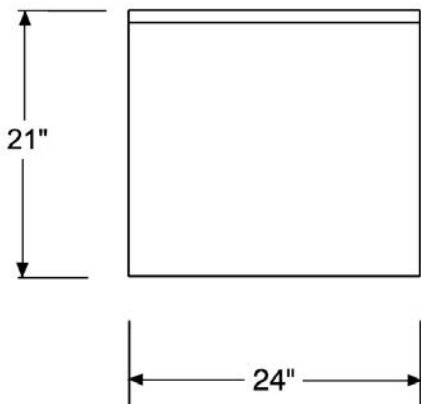
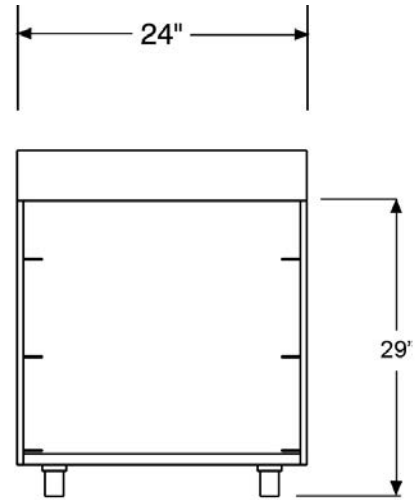
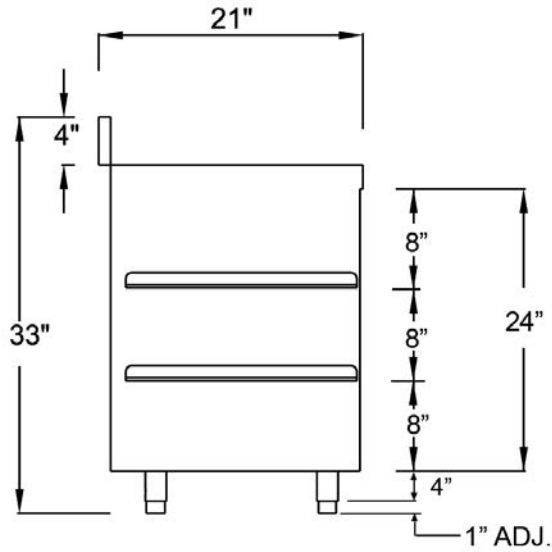

CRCR-24 TOP

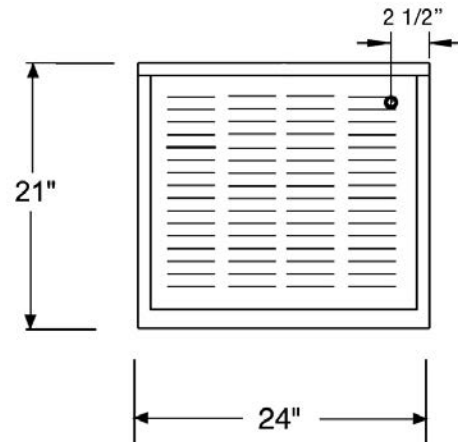

CRCR-24-CT TOP

