

DCM-751B_H-OS

OPTI-SERVE SERIES

SANITARY CUBELET ICE MACHINE/DISPENSER

Item # _____

Project: _____

Qty: _____

*AutoCad available on KCL

DCM-751B_H-OS

5/12

Item # 13291

DIMENSIONS

W x D x H

DCM-751B_H-OS

34^{1/16} x 28^{1/2} x 48^{1/16}

SD-700

34^{1/4} x 28^{1/4} x 32^{1/2}

SD-750

34 x 28 x 32^{3/4}

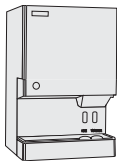

DCM-751
Countertop

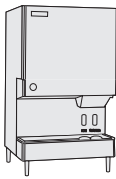

DCM-751
Countertop
with optional
6" legs

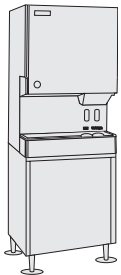

DCM-751
Floor Model
with optional
stand

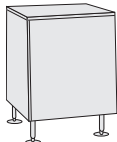

SD-700
optional
stand



SD-750
optional
stand

DCM-751BAH-OS

Air-Cooled
Shown on an optional
SD-750 Stand



DCM-751BWH-OS

Water-Cooled



*Transparent drinkware may affect dispensing operations

DCM-751B_H-OS

- CleanCycle12® - Every 12 hours, unit performs 15 minute purge to rid itself of impurities 
- LED Remote sensor for hands-free operation
- Sealed LED housing prevents moisture from entering, eliminating the possibility of an electrical short
- Corrosion resistant stainless steel exterior
- Up to 80l lbs. of ice production per 24 hours, with 95 lbs. built-in storage
- Easy to chew, cubelet ice
- Self contained design reducing opportunities for cross contamination
- Dispenses ice and water
- Removable air filters (Air-cooled model only)
- Protected by H-GUARD Plus Antimicrobial Agent 

SD-700 Stand / SD-750 Stand

- Heavy duty stand for floor model icemaker/dispenser
- Corrosion resistant stainless steel exterior
- Easy cleaning with attractive appearance
- Locking doors standard on SD-750

Warranty

Valid in United States, Canada, Puerto Rico, & U.S. Territories. Contact factory for warranty in other countries.

Three Year - Parts & Labor on entire machine. (Serial numbers Vxxxxxj) and after.)

Five Year - Parts on: Compressor, air-cooled condenser.



ISO9001-ISO14001

© HOSHIZAKI AMERICA, INC.

618 Hwy. 74 S., Peachtree City, GA 30269

TEL 1-800-438-6087

FAX 1-800-345-1325

www.hoshizaki.com



SANITARY CUBELET ICE MACHINE/DISPENSER - OPTI-SERVE SERIES

DIMENSIONS

W x D x H

DCM-751B_H-OS
 $34\frac{1}{16} \times 28\frac{1}{2} \times 48\frac{1}{16}$
SD-700
 $34\frac{1}{4} \times 28\frac{1}{4} \times 32\frac{1}{2}$
SD-750
 $34 \times 28 \times 32\frac{3}{4}$

- Hands-free ice machine/dispenser
- Optional stand
- Optional stand with locking doors

AIR-COOLED

Water Temp° F.	50°	70°	90°
Air Temp° F. 70°	801	757	725
Air Temp° F. 80°	695	666	639
Air Temp° F. 90°	612	583	562

WATER-COOLED

Water Temp° F.	50°	70°	90°
Air Temp° F. 70°	800	779	758
Air Temp° F. 80°	738	719	700
Air Temp° F. 90°	681	685	646

UTILITY CONSUMPTION

Model Number	KWH per 100 LBS. 90/70	Potable Water Gal. per 100 lbs.
DCM-751BAH-OS	5.94	12.0
DCM-751BWH-OS	4.77	12.0

SPECIFICATIONS

Model Number	Condenser	Min. Circuit Ampacity	Shipping Weight
DCM-751BAH-OS	Air-Cooled	20	345 lbs.
DCM-751BWH-OS	Water-Cooled	20	345 lbs.
SD-700	N/A	N/A	165 lbs.
SD-750	N/A	N/A	125 lbs.

CUBELET DIMENSIONS

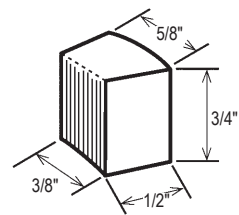

ELECTRICAL & PLUMBING/DCM-751B_H-OS

- 115V/60/1
- 20 amp Max Fuse Size
- 1/2" OD copper or equivalent independent water supply
- 3/4" independent drain connection



ISO 9001:2015 14001

© HOSHIZAKI AMERICA, INC.

618 Hwy. 74 S., Peachtree City, GA 30269

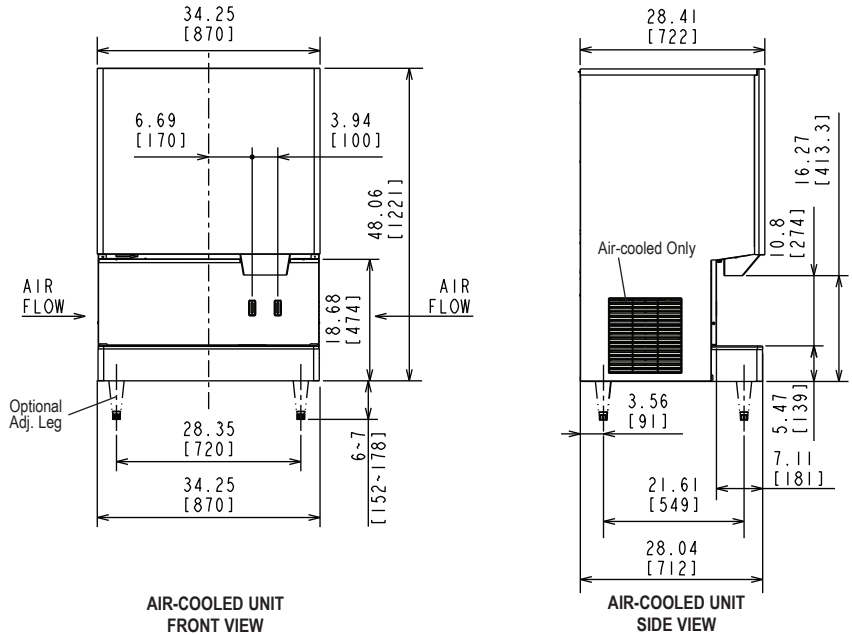

AIR-COOLED UNIT
FRONT VIEW

AIR-COOLED UNIT
SIDE VIEW

ELECTRICAL SUPPLY
7/8" DIA. OPENING

ICEMAKER WATER
INLET 1/2" FPT

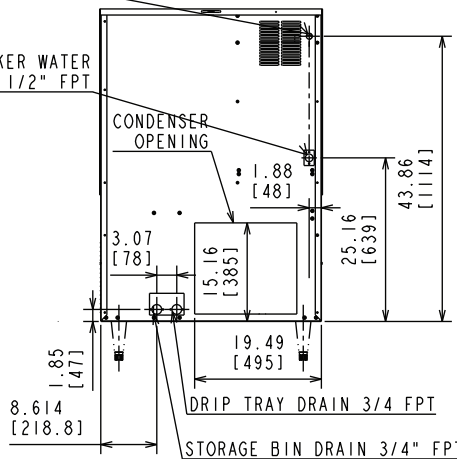

AIR-COOLED UNIT
BACK VIEW

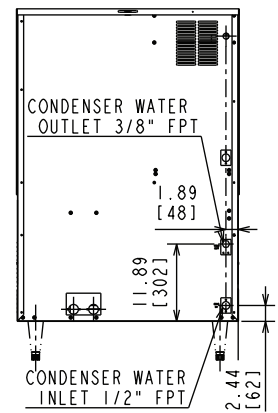

WATER-COOLED UNIT
BACK VIEW

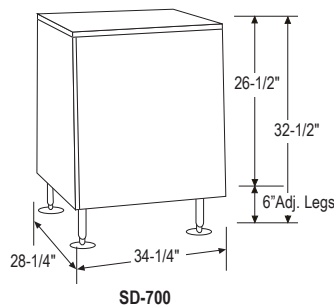

SD-700

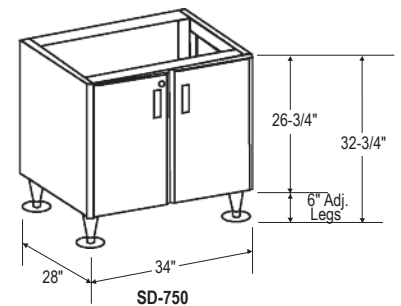

SD-750

OPERATING LIMITS

- Ambient Temp Range 45 - 100°F
- Water Temp Range 45 - 90°F
- Water Pressure 10 - 113psig
- Voltage Range 104 - 127V

SERVICE

- Panels easily removed and all components accessible for service.
- Removable/cleanable air filter.

TEL 1-800-438-6097

FAX 1-800-345-1325

www.hoshizaki.com

Printed in U.S.A.

A City Discount

