

DCM-300BAH-OS

Item # _____

Project: _____

Qty: _____

*AutoCad available on KCL

OPTI-SERVE SERIES SANITARY CUBELET ICE MACHINE/DISPENSER

DCM-300BAH-OS

8/13

Item # 13285

DIMENSIONS W x D x H

DCM-300BAH-OS

26 x 22^{1/2} x 40

SD-450

26^{1/4} x 22 x 32^{1/2}

SD-500

25^{9/10} x 22 x 32^{3/4}

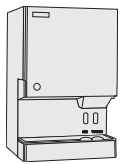

DCM-300
Countertop

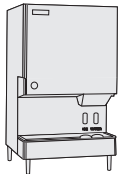

DCM-300
Countertop
with optional
6" legs

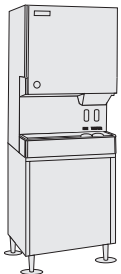

DCM-300
Floor Model
with optional
stand

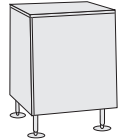

SD-450
optional
stand

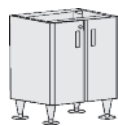

SD-500
optional
stand



DCM-300BAH-OS

Air-Cooled
Shown on an optional
SD-500 Stand



*Transparent drinkware may affect dispensing operations

DCM-300BAH-OS

- CleanCycle12® - Every 12 hours, unit performs 15 minute purge to rid itself of impurities 
- LED Remote sensor for hands-free operation
- Sealed LED housing prevents moisture from entering, eliminating the possibility of an electrical short
- Corrosion resistant stainless steel exterior
- Up to 321 lbs. of ice production per 24 hours, with 40 lbs. built-in storage
- Easy to chew, cubelet ice
- Self contained design reducing opportunities for cross contamination
- Dispenses ice and water
- Removable air filters (Air-cooled model only)
- Protected by H-GUARD Plus Antimicrobial Agent 

SD-450 Stand / SD-500 Stand

- Heavy duty stand for floor model icemaker/dispenser
- Corrosion resistant stainless steel exterior
- Easy cleaning with attractive appearance
- Locking doors standard on SD-500



ISO9001-ISO14001

Warranty

Valid in United States, Canada, Puerto Rico, & U.S. Territories. Contact factory for warranty in other countries.

Three Year - Parts & Labor on entire machine. (Serial numbers Vxxxxxj) and after.)

Five Year - Parts on: Compressor, air-cooled condenser.

© HOSHIZAKI AMERICA, INC.

618 Hwy. 74 S., Peachtree City, GA 30269

TEL 1-800-438-6087

FAX 1-800-345-1325

www.hoshizaki.com



A City Discount

DCM-300BAH-OS SANITARY CUBELET ICE MACHINE/DISPENSER - OPTI-SERVE SERIES

DIMENSIONS

	W x D x H		
DCM-300BAH-OS	26	22 ^{1/2}	40
SD-450	26 ^{1/4}	22	32 ^{1/2}
SD-500	25 ^{9/10}	22	32 ^{3/4}

- Hands-free ice machine/dispenser
- Optional stand
- Optional stand with locking doors

AIR-COOLED

Water Temp° F.	50°	70°	90°
Air Temp° F.			
70°	321	307	291
80°	277	263	249
90°	237	232	214

UTILITY CONSUMPTION

Model Number	Approximate Electrical		KWH per 100 LBS.	
	90/70	70/50	90/70	70/50
DCM-300BAH-OS	661W	653W	6.84	4.88

SPECIFICATIONS

Model Number	Condenser	Amperage	Min. Circuit Ampacity	Shipping Weight
DCM-300BAH-OS	Air-Cooled	10.25	20	240 lbs.
SD-450	N/A	N/A	N/A	110 lbs.
SD-500	N/A	N/A	N/A	98 lbs.

*CUBELET DIMENSIONS

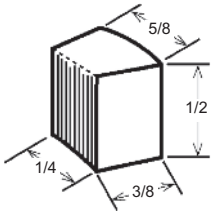

*approximate size in inches, image not to scale

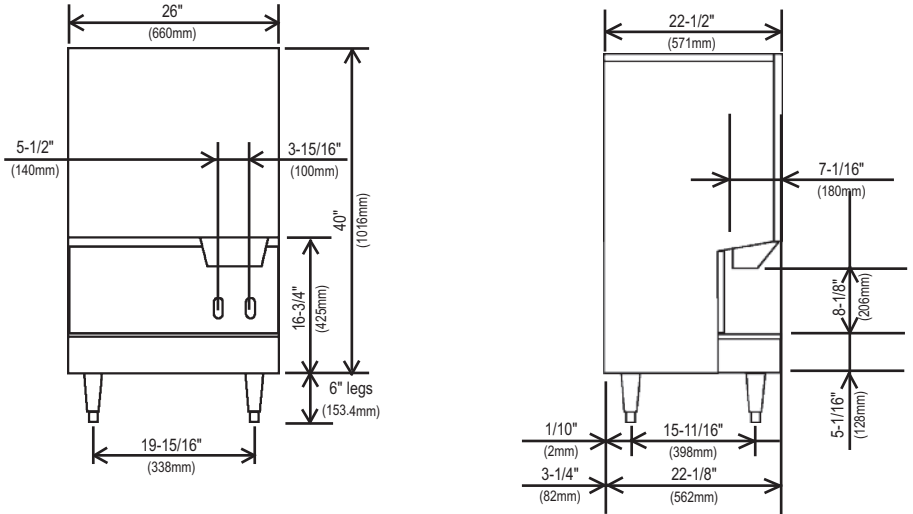

FRONT VIEW

SIDE VIEW

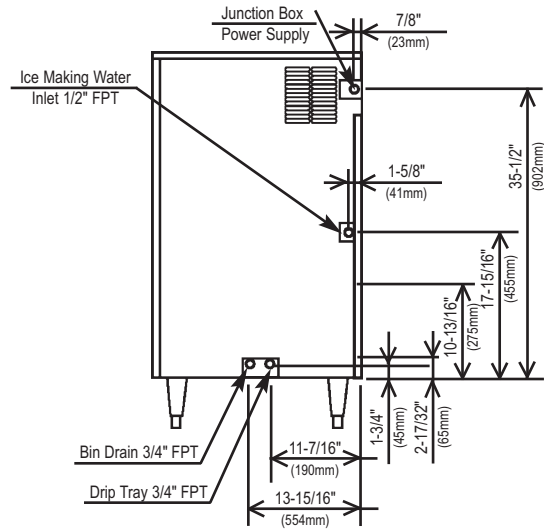

AIR-COOLED UNIT

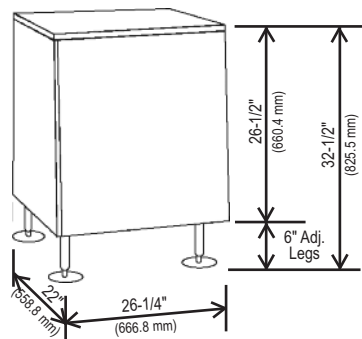

SD-450

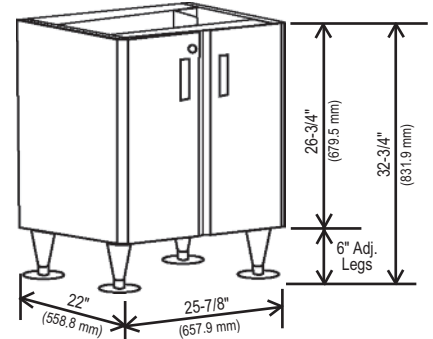

SD-500

ELECTRICAL & PLUMBING/DCM-300BAH-OS

- 115V/60/1
- 20 amp Max Fuse Size
- 1/2" OD copper or equivalent independent water supply
- 3/4" independent drain connection



ISO 9001 • ISO 14001

© HOSHIZAKI AMERICA, INC.

618 Hwy. 74 S., Peachtree City, GA 30269

OPERATING LIMITS

• Ambient Temp Range	45 - 100°F
• Water Temp Range	45 - 90°F
• Water Pressure	10 - 113psig
• Voltage Range	104 - 127V

SERVICE

- Panels easily removed and all components accessible for service.
- Removable/cleanable air filter.

TEL 1-800-428-6087

FAX 1-800-345-1325

www.hoshizaki.com

Printed in U.S.A.

A City Discount

