

Designed For Lower Volume Applications
 Two - 4 oz. Servings per Minute - 10-Quart Capacity
Great for Cafés, Restaurants and product sampling

DuraFreeze 200

Countertop
 Soft Serve Ice Cream /
 Yogurt Machine

★ New Item for 2005 ★

The new **SaniServ DuraFreeze 200** Soft Serve/Yogurt Machine is ideal for providing small servings, samplers, and adding a-la-mode to favorite desserts. Economical in price and space, **DuraFreeze** offers the prospect for high profits and customer satisfaction.

Space Saving

Small Footprint Design -The **SaniServ DuraFreeze 200** saves valuable floor space and turns the countertop into a real profit center by serving high profit ice cream and yogurt products.

Easy Cleaning and Operation

Fewer Parts = Simplified Cleaning – **SaniServ** equipment is designed and built with the fewer parts to be disassembled, cleaned and sanitized than any other machine in the industry.

High Return on Investment

Increased Profits – **SaniServ** machines combine efficiency with consistent product quality and fast quiet operation while insuring customer satisfaction with high profit ice cream or yogurt products.

Quality Design

Durability – **SaniServ** machines are built to achieve long and dependable life through simplicity of design. Every machine is shipped standard with durable stainless steel exterior construction and heavy-duty components / product consistency system.



Made in the USA

DuraFreeze 200

Counter Model Softserv / Yogurt Freezer

For sales information contact:

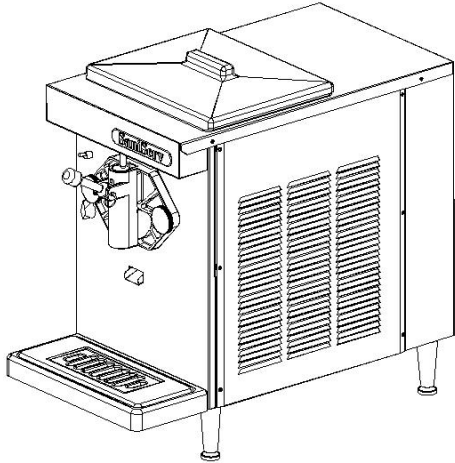

Minimum Wall Clearance
Both Sides and Back -
4 inches (102 mm)

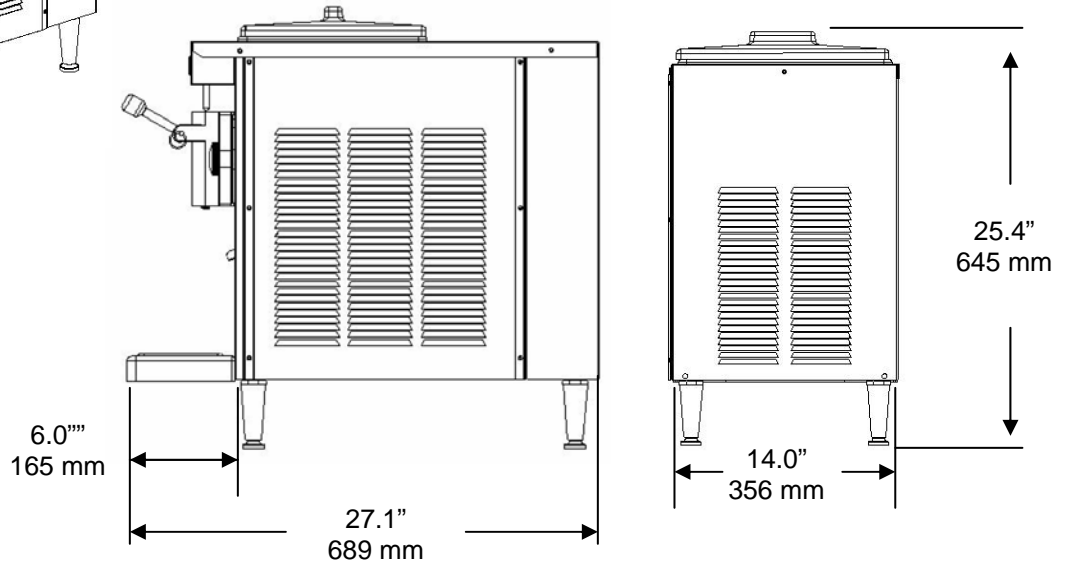

	WIDTH INCHES (mm)	HEIGHT INCHES (mm)	DEPTH INCHES (mm)	VOLTS/HZ/PHASE	AMPS	WEIGHT LBS (kg)
MACHINE	14.0 (356)	25.4 (645)	27.1 (689)	115/60/1	11.0	145 (66)
MACHINE CRATED	18.5 (470)	25.5 (648)	31.5 (800)			172 (78)

Quick Recovery...
Compact and Durable...
Simple in design for easy cleaning...
Heavy duty components...

Evaporator and Mix Reservoir Capacity: 7 Quarts (6.6 liters)

Construction: Stainless Steel Exterior with Legs Standard.

Dasher: Heavy-Duty Stainless Steel with low friction scraper blade.

Dasher and Compressor Motors:
1/4 HP Dasher 1/3 HP Compressor

Shipping Volume: 8.6 Cubic Ft (0.24 cubic m)

Refrigerant Type: R404A

Warranty:
 Parts 90 days
 Labor 30 days
 Compressor 1 year

Listings: UL, cUL, NSF

We reserve the right to change specifications and product design without notice. Such revisions do not entitle the buyer to corresponding changes, improvements, additions or replacements for previously purchased equipment.

Electrical: 115/60 Hz/1Ø/11Amp

Controls: Automatic consistency control.