



## Cooker/Mixer models DHT-40 INA/2 & DHT-60 INA/2

### Description

Cooker/Mixer shall be a Groen Model DHT-40 or 60, INA/2 gallon (specify 40 or 60) stainless steel, self-contained, 2/3 steam jacketed unit operating from a gas heated steam source contained within unit and complete with console mounted tilt out inclined agitator mixer.

### Construction

Kettle interior shall be of 316 stainless steel, solid one-piece welded construction. The control console and kettle exterior shall be 304 stainless steel. The kettle body shall be mounted on a heavy duty stainless steel, combination kettle support tilt trunnion which is supported by the polished stainless steel enclosed base. The kettle shall be furnished with heavy duty reinforced rim with a butterfly shaped pouring lip for maximum sanitation and ease of pouring. The base shall be provided with stainless steel tubular legs with adjustable flanged feet. The enclosed support base shall contain a self-locking worm and gear tilt mechanism, controls, etc., and shall be of sanitary drip-proof construction with interior readily accessible for installation or maintenance. Unit includes 2" TDO and 10-gallon etch markings and double pantry faucet.

### Finish

Interior of kettle shall be polished to a 180 emery grit finish. Exterior of kettle shall be finished to a bright semi-deluxe finish, ensuring maximum ease in cleaning and maintaining brilliant appearance.

### Agitator Assembly

Agitator assembly to be designed to thoroughly fold and blend product with gentle lifting action provided by agitator entering kettle body at an angle. Inclined agitator to be stainless steel tubular frame, complete with shovel-type scrapers. Agitator to be readily removable for ease of cleaning and maximum sanitation.

Unit driven by a gear motor through an electronic variable speed control. Motor is completely enclosed-type with a cast iron housing, helical bevel gearing and right angle shaft down. Motor drive is mounted on a stainless steel channel that manually hinges out to the right side of kettle. Unit to be equipped with a spring assist for agitator tilt-out. A positive quick-acting lock and latch mechanism to be provided to secure the agitator when it is in the kettle.

### ASME Code & UL Listing

Unit shall be ASME shop inspected, stamped and registered with the National Board for operation up to a maximum working pressure of 50 PSI. Kettle is UL listed. Kettle shall be design certified by CSA America for use with natural gas or LP gas.

### Sanitation

Unit shall be designed and constructed to meet NSF requirements, and be NSF listed.

### Self Contained Steam Source

Kettle shall have a gas heated (natural or propane) self-contained steam source to provide kettle temperatures of 150°F to approximately 295°F. Unit shall be factory

Model DHT-40, INA/2 shown



charged with water and rust inhibitors to ensure long life and minimum maintenance.

### Controls

Controls shall include a thermostat, gas control valve with pressure regulator, pressure gauge, water sight glass, gas regulator valve, power ON switch, power ON indicator light, low water indicator light, agitator ON-OFF switch, motor speed control and double-pantry faucet with bracket. Electronic ignition to standing pilot is standard on all models.

Agitator to be electronic, variable speed control-type capable of operation at any RPM between minimum and maximum settings.

### Safety Features

Kettle shall have safety cut-off (cuts off heat when tilted to 10°F and above), pressure relief valve, high limit pressure switch and low water cut off, 24V control system, and agitator safety tilt cut off.

### Options/Accessories

- Disk strainers (not to be used with agitator)
- 240, 480 Volt power supply (for agitator motor)
- Kettle brush kit
- Pan carrier
- Gallon master
- Basket insert

### Installation Requirements

Specify natural or propane gas. Unit requires 1/2" NPT gas line connection, 115 volt, 60Hz power for kettle and 208 volt (3-phase only) power for agitator motor. No remote steam source required.

### Origin of Manufacture

Cooker/Mixer shall be designed and manufactured in the United States.

**Stainless Steel  
2/3 Steam Jacketed  
Cooker/Mixer**

**Floor Mounted  
Tilting  
Self-Contained  
Gas Heated  
40 and 60-Gallon  
Capacities With  
Inclined Agitator**

### Short Form

Groen Model DHT-40 or 60, INA/2 (specify gallons) self-contained, tilting, gas heated, stainless steel 2/3 steam jacketed cooker/mixer with twin inclined agitator scraper mixer. Base shall house, positive lock, smooth-action, manual-tilt assembly. 316 stainless steel kettle interior has solid, one-piece, welded construction with heavy-duty reinforced rim and butterfly-shaped pouring lip. Inclined agitator mounted on console with mechanically assisted manual tilt-out and positive quick action rim lock and latch. Unit is standard with 2" TDO valve and etch marks. Kettle is NSF and UL Listed, ASME code constructed for 50 PSI. Standard 208 volt, 3-phase for kettle, 208 volt, 3-phase for agitator motor. Made in USA.



### Applications

- Meats
- Soups
- Stews
- Sauces
- Pie fillings
- Pudding
- Beans
- Powdered mixes
- Icings
- Custards

AGITATOR MOTOR DATA SPECIFICATIONS				
		H.P.	RPM MAIN	RPM SECONDARY
40 GAL	MAXIMUM	1-1/2	54	150
	MINIMUM	3/4	27	75
60 GAL	MAXIMUM	2	46	120
	MINIMUM	1	23	60

TABLE OF DIMENSIONS				
MODEL	40 GAL. 150 L		60 GAL. 230 L	
DIM.	INCH	MM	INCH	MM
A	26	660	30	762
B	28-1/2	724	31-5/8	803
C	31	787	33	838
D	48	1219	54	1372
E	58-7/8	1495	62-1/8	1578
F	39-1/2	1003	42-3/4	1086
G	11-1/4	286	14-1/2	368
J	30-1/2	775	35-1/2	902
K	78-1/8	1984	81-3/8	2067
L	6-7/8	175	8-7/8	225
M	14-1/4	362	12-3/8	314

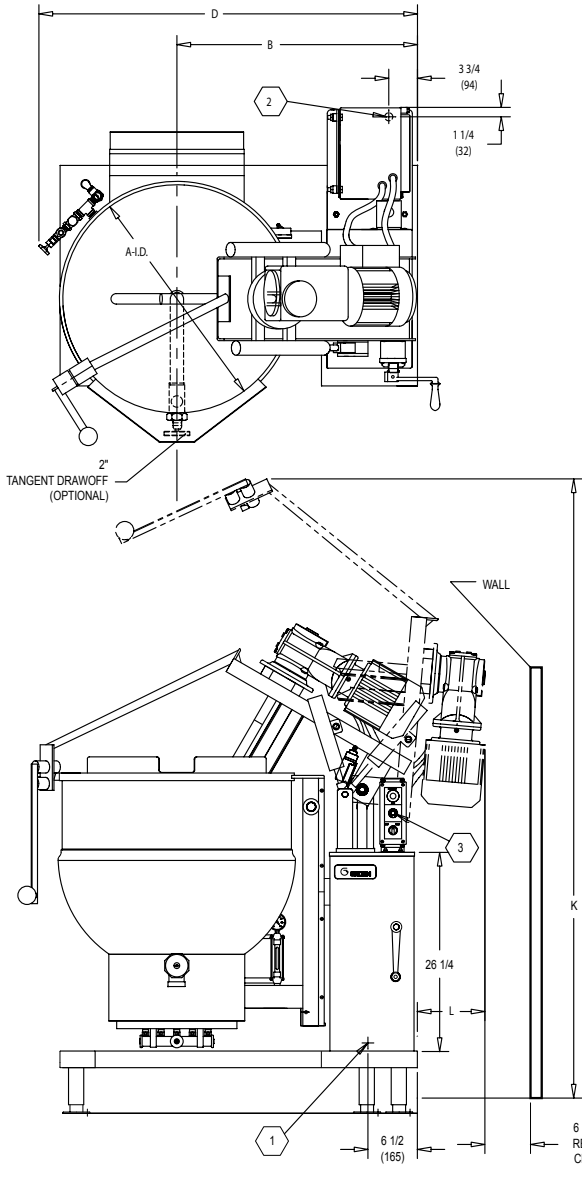

**NOTES:**

1. ELECTRICAL POWER CONNECTIONS, KETTLE  
1-3/4" DIAMETER HOLE.
2. ELECTRICAL POWER CONNECTION, AGITATOR  
1-3/4" DIAMETER HOLE.
3. AGITATOR MOTOR SPEED SELECTOR SWITCH.
4. CONTROL BOX MAY BE REMOTELY MOUNTED  
(BY CUSTOMER) IF DESIRED.

