

DKM-500B_H

CRESCENT CUBER ICE MACHINE AND DISPENSER

SERENITY SERIES

Item # _____

Project: _____

Qty: _____

*AutoCad available on KCL

DKM-500B_H

2/12

Item # 13225

DIMENSIONS

W x D x H

DKM-500B_H
30 x 28 x 77*

*with 6" legs
(or optional casters)

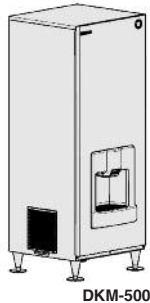

DKM-500BAH

Air-Cooled
Shown with optional
6" casters

DKM-500BWH

Water-Cooled

- Ice dispensing height is ADA Compliant
- Up to 466 lbs. of ice production per 24 hrs.
- Insulated polyethylene bin has a storage capacity of 200 lbs.
- 35% quieter compared to other hotel dispenser applications
- Durable, attractive one piece stainless steel exterior design
- One piece design allows for easy installation and serviceability
- Self-contained design reduces opportunities for cross contamination
- Protected by *H-GUARD Plus* Antimicrobial Agent 
- Push button operated; dispenses 13 lbs. of ice per minute
- 6" Flanged legs are standard
- Optional 6" casters available
- Water valve accessory as an option
- CycleSaver® design 
- R-404A Refrigerant

* The DKM-500BAH is ENERGY STAR qualified.

Warranty

Valid in United States, Canada, Puerto Rico, & U.S. Territories. Contact factory for warranty in other countries.

Three Year - Parts & Labor on entire machine.

Five Year - Parts on: hermetic compressor, air-cooled fin and tube type condenser.



ISO 9001 • ISO 14001

© HOSHIZAKI AMERICA, INC.

618 Hwy. 74 S., Peachtree City, GA 30269

TEL 1-800-438-6087

FAX 1-800-345-1325

www.hoshizaki.com



DKM-500B_H CRESCENT CUBER ICE MACHINE AND DISPENSER SERENITY SERIES

DIMENSIONS

W x D x H

DKM-500B_H
30" x 28" x 77"

*with 6" legs
(or optional casters)

- Air-cooled
- Water-cooled

AIR-COOLED

Water Temp ° F.	50°	70°	90°
Air Temp ° F.			
70°	466	448	420
80°	453	425	395
90°	448	436	376

WATER-COOLED

Water Temp ° F.	50°	70°	90°
Air Temp ° F.			
70°	455	450	419
80°	451	444	399
90°	450	439	399

STORAGE BINS

Model Number	Application Capacity	ARI-Rated Capacity
DKM-500BAH	200 lbs.	140 lbs.
DKM-500BWH	200 lbs.	140 lbs.

UTILITY CONSUMPTION

Model Number	Ice Production per Cycle		KWH per 100 LBS.		Potable Water Gallons per 100 lbs.
	Lbs.	Cubes	90/70	70/50	
DKM-500BAH	7.2	360	6.53	5.4	22.4
DKM-500BWH	7.5	360	5.1	4.9	26.7

SPECIFICATIONS

Model Number	Condenser	Amperage	Min. Circuit Ampacity	Shipping Weight
DKM-500BAH	Air-Cooled	13.3	15	410 lbs.
DKM-500BWH	Water-Cooled	10.7	15	372 lbs.

ELECTRICAL & PLUMBING/DKM-500B_H

- 115V/60/1
- 1/2" FPT Water Inlet
- 3/4" FPT x2 Drain



BSL09001-15C14901

© HOSHIZAKI AMERICA, INC.

618 Hwy. 74 S., Peachtree City, GA 30269

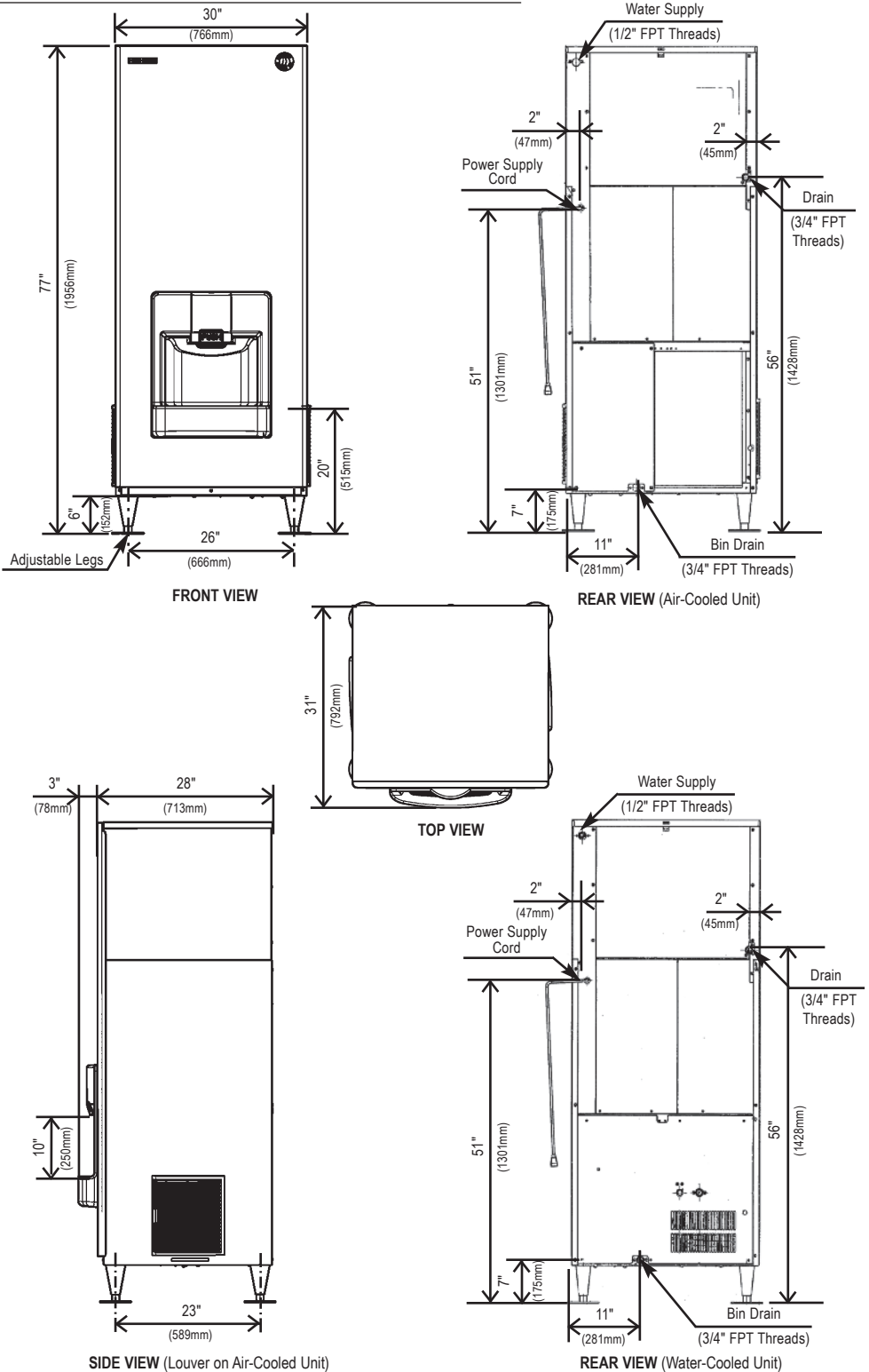

OPERATING LIMITS

- Ambient Temp Range 45 - 100°F
- Water Temp Range 45 - 90°F
- Water Pressure 10 - 113psig
- Voltage Range 104 - 127V

SERVICE

- Panels easily removed and all components accessible for service.
- Removable/cleanable air filter. (Air-Cooled model only)

TEL 1-800-438-6087

FAX 1-800-345-1325

www.hoshizaki.com

Printed in U.S.A.

A City Discount

