



Free Standing Bulb Warmers

B1A, B1B, B2A, B2B, B3A, B3B, B1-2

Keep cooked foods fresh and appetizing from preparation to serving!



Model B2B

Merco Free Standing Bulb Warmers are ideal for fried foods, hors d'oeuvres, rolls, cob corn or any cooked food.

Standard Features

Aluminum alloy construction. Ventilated aluminum reflectors with heavy-duty electrical sockets. 6-foot cordset with in-line on/off switch (two on model B1-2).

Merco Free Standing Bulb Warmers are manufactured from specially selected alloys for long life and easy cleaning. Models are available in 1, 2, and 3 bulb configurations as well as a special 3 bulb unit for most commercial food slicers (B1-2). All models are designed for maximum stability, and feature adjustable arms to vary the height for perfect warming of any hot food. Standard equipment includes a 6-foot cordset with in-line on/off switch conveniently located out of the heat zone (two cordsets on Model B1-2 Slicer Warmer). No matter which model you choose, you'll be getting the most for your money.

Electrical Requirements

All models are available in 120 or 240 volts, single phase AC only. 120 volt units are furnished with white bulbs (red bulbs optional). 240 volt units are furnished with red bulbs only.



Model B3B



1111 North Hadley Road
P.O. Box 1229
Fort Wayne, IN 46801-1229
Phone: (260) 459-8200 / Fax: (260) 459-8240
Toll Free 800 547-2513



Models B1A and B1B not CSA Listed

Printed in USA,
Designs and specifications are subject to change without notice
© 2001 Merco Products, Inc., All Rights Reserved

Free Standing Bulb Warmers

B1A, B1B, B2A, B2B, B3A, B3B, B1-2

Dimensions (inches/cm)

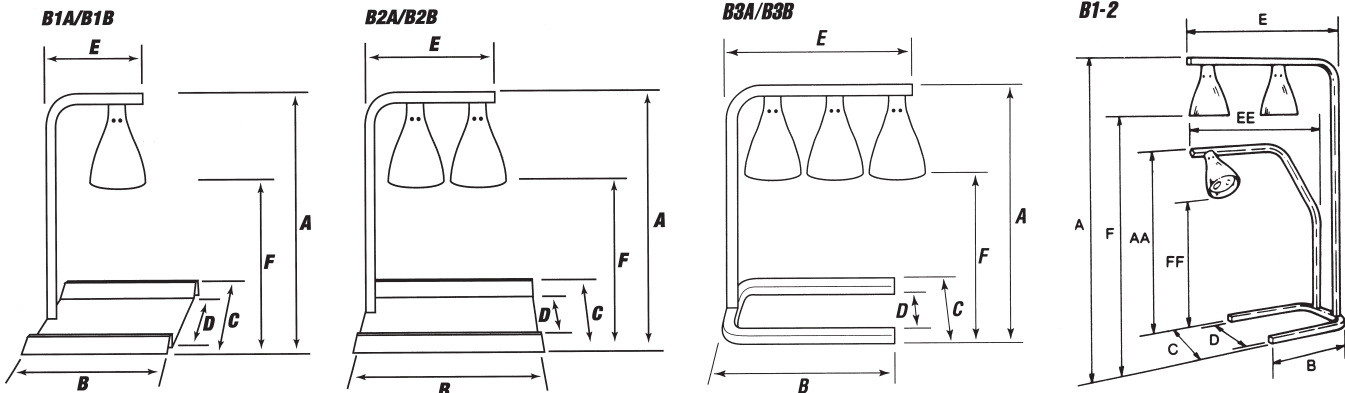

	B1A B1B	B2A B2B	B3A B3B	B1-2
A	20-28/50.8-71.1	19.75-2.7/50.2-70.5	25.5-33.5/64.8-85.1	38.5-42.5/97.8-1-8
B	11.75/29.8	15.75/40	22.5/57.2	15.75/40
C	13.875/35.2	13.875/35.2	20.5/52.1	13.875/35.2
D	11.875/30.2	11.875/30.2	18.5/47	11.875/30.2
E	10.25/26	16.75/42.5	24/61.0	26/66
F	11.5-19.5	11.25-19.25/28.6-48.9	17-25/43.2-63.5	30-34/76.2-86.4
FF	-	-	-	13.75/34.9
EE	-	-	-	18.375/47
AA	-	-	-	22.125/56.3

Specifications

(Standard 8-inch-depth models)

MODEL #	VOLTAGE/AMPS			WATTS	DIMENSIONS inches/cm	NET WT.* lbs/kg	SHIP WT.* lbs/kg	SHIP VOL.* cu ft/cu m
	120V	208V	240V**					
B1A**	2.1	N/A	1.0	250	See Drawings Above	4/1.8	9/4.1	2.5/0.07
B1B**	2.1	N/A	1.0	250		8/3.6	11/5.0	2.5/0.07
B2A	4.2	N/A	2.1	500		6/2.7	12/5.4	2.5/0.07
B2B	4.2	N/A	2.1	500		10/4.5	14/6.4	2.5/0.07
B3A	6.3	N/A	3.1	750		10/4.5	16/7.3	4.3/0.12
B3B	6.3	N/A	3.1	750		18/8.2	24/10.9	4.3/0.12
B1-2	6.3	N/A	3.1	750		19/8.6	27/12.3	4.3/0.12

*Measurements are approximate. **Models B1A and B1B are not CSA Listed. 240 Volt units are not UL or CSA Listed.

Options & Accessories

Red bulb(s) for 120VAC units.

Powder-coat finish

Bid Specifications for Free Standing Bulb Warmers

The Free Standing Bulb Warmer shall be Merco model number _____, rated at _____ watts, _____ volts, single phase AC, color _____. Equipment shall include aluminum construction, heavy-duty electrical socket(s), 6-foot cordset(s) with in-line on/off switch(es), white bulb(s) if 120VAC and red bulb(s) if 240VAC.

12" x 10" stainless steel pan with wire trivet (Model B1B only).

12" x 20" stainless steel pan with wire trivet (Model B2B only) or

18" x 26" aluminum pan with wire trivet (Model B3B only).

 **Merco Savory**

Enodis

1111 North Hadley Road

P.O. Box 1229

Fort Wayne, IN 46801-1229

Phone: (260) 459-8200 / Fax: (260) 459-8240

Toll Free 800 547-2513

Merco Guarantee

Ninety (90) days labor; One (1) year parts warranty from date of purchase (excluding light bulbs and lamps).