

HOSHIZAKI

Series

F-450M_H(C)
Item # 13133 9/03

SLIM-LINE MODULAR FLAKER/CUBELET F-450MAH(C) SERIES

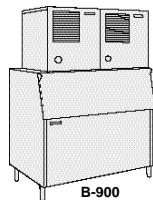
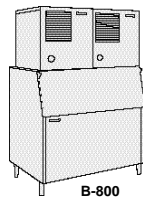
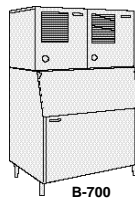
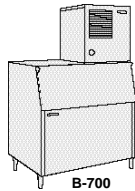
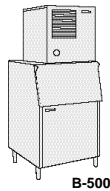
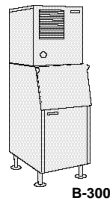

F-450MAH Flaker
Shown on Optional
B-300 Bin

F-450MAH
Air-Cooled
F-450MAH-C
Air-Cooled

- Durable stainless steel exterior
- F-450MAH - Up to 476 lbs. of ice production per 24 hours
- F-450MAH-C - Up to 426 lbs. of ice production per 24 hours
- CleanCycle12® system 
- 15 minute flush cycle every 12 hours
- Removes sediment
- Cleaner ice
- Longer life and easy maintenance

ICEMAKER DIMENSION

Width x Depth x Height
F-450M_H(C)
21⁷/₈ x 27³/₈ x 22

DIMENSION BYBIN SIZE

Width x Depth x Height
B-300
22 x 32¹/₂ x 68
B-500
30 x 32¹/₂ x 68
B-700
44 x 32¹/₂ x 68
B-800
48 x 32¹/₂ x 68
B-900
52 x 32¹/₂ x 68

© HOSHIZAKI AMERICA, INC.

618 Hwy. 74 S., Peachtree City, GA30269

1-800-438-6087

FAX 1-800-345-1325

TEL 770-487-2331

www.hoshizaki.com



Reliability is a beautiful thing™



F450M_H-(C) SERIES

DIMENSIONS (Inches) - CONNECTIONS

SLIM-LINE MODULAR FLAKER/CUBELET

F-450MAH (AIR-COOLED)
F-450MAH-C (AIR-COOLED)

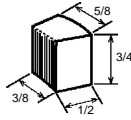

- **F-450MAH** - Up to 476 lbs. of ice production per 24 hours
- **F-450MAH-C** - Up to 426 lbs. of ice production per 24 hours



WARRANTY TWOYEAR - Parts & Labor on entire machine. FIVE YEAR - Parts on: Compressor, Air-Cooled Condenser Coil.	STAINLESS STEEL INTERNAL AUGER	SERVICE Panels easily removed and all components accessible for service. Removable/cleanable air filters.
	R-404 REFRIGERANT	

Warranty valid in United States, Canada, Puerto Rico, & U.S. Territories.
 Contact Factory for Warranty in other Countries.

STORAGE BINS

- B-300 - 300 lb. Application Capacity (260 lb. ARI-Rated Capacity Bin)
- B-500 - 500 lb. Application Capacity (360 lb. ARI-Rated Capacity Bin)
- B-700 - 700 lb. Application Capacity (550 lb. ARI-Rated Capacity Bin)
- B-800 - 800 lb. Application Capacity (600 lb. ARI-Rated Capacity Bin)
- B-900 - 900 lb. Application Capacity (660 lb. ARI-Rated Capacity Bin)
- B-1200 - 1200 lb. Application Capacity
- B-1500 - 1500 lb. Application Capacity

OPERATING LIMITS

Ambient Temp Range 45 - 100°F
 Water Temp Range 45 - 90°F
 Voltage Range 104-127V
 Water Pressure 10 - 113 psig

ELECTRICAL & PLUMBING

115V/60/1 20 amp max fuse
 3/8" OD copper or equivalent independent water supply
 3/4" independent drain connection

Clean Cycle 12®: 15 minute flush cycle every 12 hours to ensure bearings longer life

AIR - COOLED - F-450MAH

Water Temp ° F.		50°	70°	90°
Air Temp ° F.	70°	476	456	435
	80°	416	397	379
	90°	362	355	330

AIR - COOLED - F-450MAH-C

Water Temp ° F.		50°	70°	90°
Air Temp ° F.	70°	426	407	387
	80°	368	350	333
	90°	317	310	287

UTILITY CONSUMPTION

Model Number	Approximate Electrical		KWH per 100 lbs.	
	90/70	70/50	90/70	70/50
F-450MAH	915W	858W	6.2	4.3
F-450MAH-C	956W	880W	7.4	5.0

SPECIFICATIONS

Model Number	Condenser	Amperage	Min. Circuit Ampacity	Shipping Weight
F-450MAH	Air-Cooled	11.0	20	195 lbs.
F-450MAH-C	Air-Cooled	11.0	20	195 lbs.

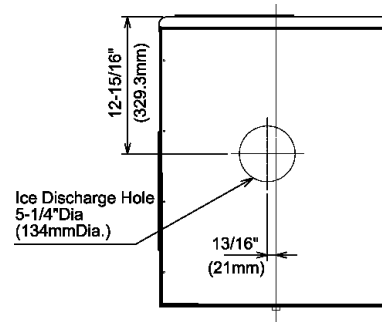
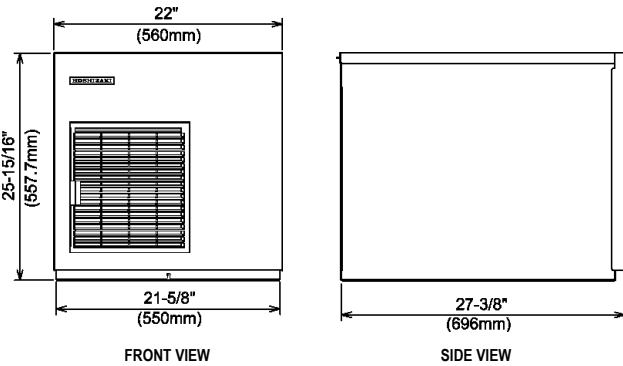

ICEDROPZONE

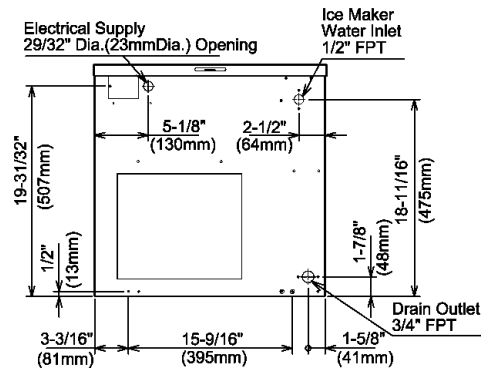

AIR-COOLED UNIT

We reserve the right to change specifications without notice.

© HOSHIZAKI AMERICA, INC.

618 Hwy. 74 S., Peachtree City, GA30269

1-800-438-6087

FAX 1-800-345-1325

TEL 770-487-2331

www.hoshizaki.com

Printed in U.S.A.