

**G****GAS FIRED STEAM  
JACKETED TILT KETTLE**

JOB NAME: \_\_\_\_\_

ITEM NO.: \_\_\_\_\_

NO. REQUIRED: \_\_\_\_\_

**MODEL:**       FT-12CG 12-Gallon (46 liters)**DESCRIPTION:**

Shall be a Market Forge FT-12CG gas fired, self-contained steam jacketed kettle. A double wall kettle interior shall form a steam jacket around the lower 2/3 of the kettle. The jacket enclosure shall contain factory sealed water and antifreeze. Kettle exterior is fully insulated. The bottom of the kettle shall be hemispherical designed for superior heat circulation.

The controls shall be integrally mounted to the kettle base and shall include, solid state thermostat, power switch, temperature light; ignition light, low water indicator light, electronic ignition, water sight glass and pressure gauge.

Safety features, low water shut off, burner turns off automatically when kettle is tilted, pressure switch and pressure relief valve.

The kettle construction shall be stainless steel type 304 with # 4 satin exterior finish. The interior kettle liner shall be a one piece welded construction made with type 316 stainless steel liner. A removeable operating handle with high heat proof knob shall be mounted on the right. Kettle comes standard with "Clean Lock" to hold kettle in cooking position or 105o for ease of cleaning.

**OPERATION SHALL BE BY:**

Natural or L.P. gas, ASME Code stamped for operation up to 50 PSI. The steam kettle temperature range shall be between 150°F (66°C) to 285°F (140°C). Controls shall be equipped for operation on 120 VAC 1 phase 50/60 Hz.

43,000 BTU/HR.

12.6 kW/HR.

**OPTIONAL AT EXTRA COST:**

- One piece lift off stainless steel cover.
- Stainless steel wire basket.
- Etched Gallon Marketings.
- Stainless Steel Stand with Sink/Drain - 20" High.
- Single Pantry Faucet, (*brackets included*).
- Double Pantry Faucet, (*brackets included*).

The manufacturer reserves the right to modify materials and specifications without notice.

SPEC SHEET: S-4859B  
09/13FOOD SERVICE EQUIPMENT  
Gas Steam Jacketed Kettle
**MARKET FORGE**  
INDUSTRIES INC.

35 Garvey Street • Everett • MA • 02149  
Tel: (617) 387-4100 • Fax: 1-800-227-2659 (Ex. MA) • (617) 387-4456 (MA and Overseas)  
E-Mail: CUSTSERV@mfii.com • Website: www.mfii.com

A City Discount

**G****GAS FIRED STEAM JACKETED TILT KETTLE**

JOB NAME: \_\_\_\_\_

ITEM NO.: \_\_\_\_\_

NO. REQUIRED: \_\_\_\_\_

**SERVICE CONNECTIONS****Gas Fired**

EC	Electrical Connection - Unless otherwise specified, field wire electrical connection to be 120V, 60 Hz, 1 Phase with grounding wire. Unit Furnished with 8' cord and 3-prong plug. Total max AMPS 2.0
G	Gas Connection - Supply gas through 3/4" pipe. Natural 6"-14" W.C. (152-355mm). Propane 12"-14" W.C. (305-355mm). Contact manufacturer for installation over 2,000 ft elevation.
CW	Cold Water - 3/8" O.D. tubing to faucet (optional).
HW	Hot Water - 3/8" O.D. tubing to faucet (optional).

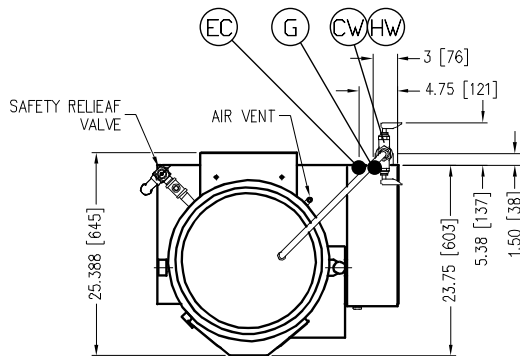

SHIPPING WT.	MIN. CLEARANCE*	
	255 lbs. [116 kg]	SIDES
BACK		6 [152]

\* Use on non-combustible floors only.

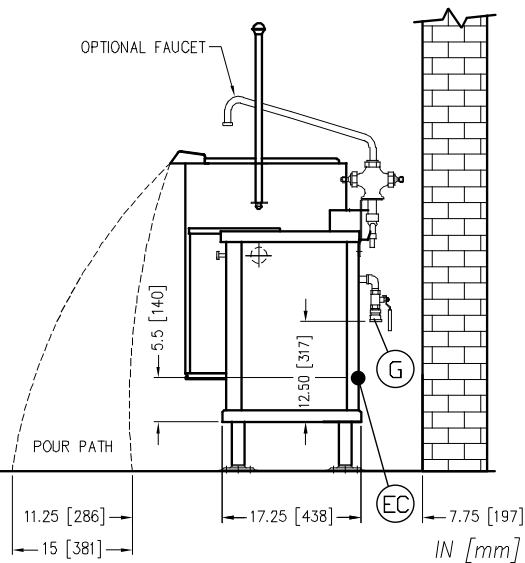
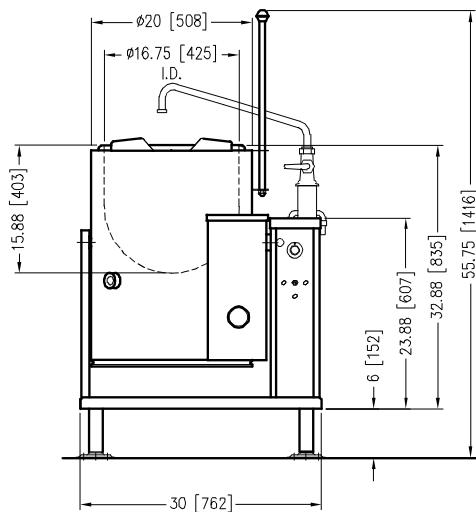

FLANGED FEET DETAIL  
 4 EQUALLY SPACED  
 ø7/16" [11mm] HOLES  
 ON 2.835" [72mm] B.C.

SPEC SHEET: S-4859B  
09/13**FOOD SERVICE EQUIPMENT**  
Gas Steam Jacketed Kettle

It is our policy to build equipment which is design certified by U.L., A.S.M.E., N.S.F. and C.S.A. However, a continuing program of product improvement makes it necessary to submit new models to the agencies as they are developed and consequently not all models bear the appropriate agency labels at all times.

**MARKET FORGE**  
INDUSTRIES INC.

PRINTED IN U. S. A.

35 Garvey Street • Everett • MA • 02149  
 Tel: (617) 387-4100 • Fax: 1-800-227-2659 (Ex. MA) • (617) 387-4456 (MA and Overseas)  
 E-Mail: CUSTSERV@mfi.com • Website: www.mfi.com

A City Discount