

E**SELF-CONTAINED ELECTRIC STEAM
JACKETED KETTLE (FLOOR MODEL)**JOB NAME: _____
ITEM NO.: _____
NO. REQUIRED: _____**MODEL:** FT- 20CE**SIZE:** 30 3/4" Wide x 24" Front-to-Back
(781mm Wide x 610mm Front-to-Back)**DESCRIPTION:**

Shall be a Market Forge Model FT-20CE Self-Contained, Electric Steam Jacketed Tilting Kettle (*Floor Model*). A double wall kettle interior shall form a steam jacket around the lower 2/3 of the kettle. The jacket enclosure shall contain water and anti-freeze which is factory sealed. The bottom of the kettle shall be of hemispherical design for superior heat circulation.

The mounting base shall include 4 stainless steel tubular legs fitted with a 4 hole adjustable foot for securing the unit to the floor and a stainless steel clad mechanism housing.

A removable operating handle with heat proof knob and tilt lock shall be mounted on the right.

Construction shall be all welded satin finish, stainless steel, type 304.

The controls shall be integrally mounted and shall include a power switch, thermostat, pilot light, vacuum/pressure gauge, safety valve, low water light, and low water shut off.

The kettle shall operate in a temperature range of 100°F to 290°F (38°C to 144°C) at a maximum pressure of 50 psi (3.4 kg/cm²). All kettles shall be standard with removable elements.

**OPERATION SHALL BE BY:**

Electrically Self-Contained closed Steam System equipped for operation on:

- 208 VAC, 1 or 3 Phase, 50/60 Hz.
- 230 VAC, 1 or 3 Phase, 50/60 Hz.
- 240 VAC, 1 or 3 Phase, 50/60 Hz.

OPTIONAL AT EXTRA COST:

- One piece Lift-Off stainless steel cover.
- 2" (50mm) Draw-Off valve.
- 3" (76mm) Draw-Off valve.
- Strainer for Draw-Off valve.
- Drain Cup with 8' Hose for 2" Draw-Off valve.
- 220/380, 240/415 VAC, 3 Phase, 4 wire.
- 380, 415 or 480 VAC, 3 Phase 50/60 Hz.
- Strainer Hook.
- Graduated Measuring Stick.
- Stainless steel wire basket.
- Vegetable Strainer.
- 12" Single Pantry Faucet, (*brackets included*).
- 12" Double Pantry Faucet, (*brackets included*).

The manufacturer reserves the right to modify materials and specifications without notice.

SPEC SHEET: S-4054B
01/14FOOD SERVICE EQUIPMENT
Steam Jacketed Kettle - Floor Model**MARKET FORGE**
INDUSTRIES INC.35 Garvey Street • Everett • MA • 02149
Tel: (617) 387-4100 • Fax: 1-800-227-2659 (Ex. MA) • (617) 387-4456 (MA and Overseas)
E-Mail: CUSTSERV@mfii.com • Website: www.mfii.com

A City Discount

E**SELF-CONTAINED ELECTRIC STEAM JACKETED KETTLE (FLOOR MODEL)**
 JOB NAME: _____
 ITEM NO.: _____
 NO. REQUIRED: _____
SERVICE CONNECTIONS**Electrically Operated**

EC	Electrical Connection - to be as specified on data plate.
----	---

ELECTRICAL CHARACTERISTICS

MODEL	pH	208V		230V		240V		380V		415V		480V	
		kW	Amp	kW	Amp	kW	Amp	kW	Amp	kW	Amp	kW	Amp
FT-20CE	1	12	33.4	12	30.1	12	28.9	12	18.3	12	16.7	12	14.5
	3	12	57.6	12	52.2	12	50.0	--	--	--	--	--	--

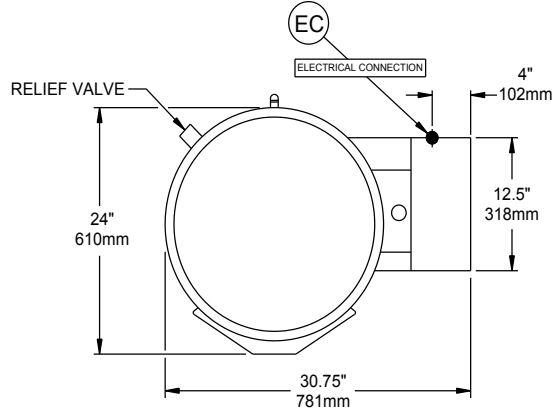
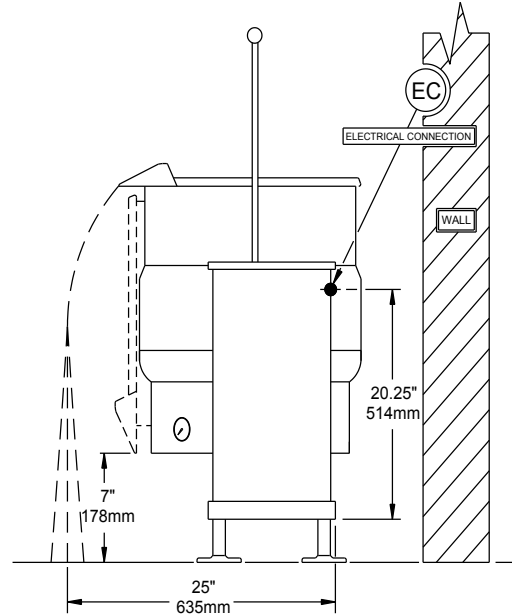
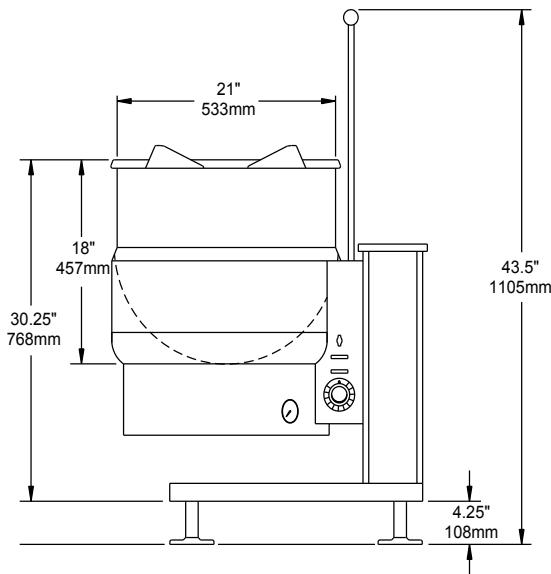
 4 EQUALLY SPACED
 7/16" 11mm DIA. HOLES
 ON 3" 76mm B.C.
 FLANGED FOOT DETAIL

It is our policy to build equipment which is design certified by U.L., A.S.M.E., N.S.F. and C.S.A. However, a continuing program of product improvement makes it necessary to submit new models to the agencies as they are developed and consequently not all models bear the appropriate agency labels at all times.

 SPEC SHEET: S-4054B
 01/14

FOOD SERVICE EQUIPMENT
 Steam Jacketed Kettle - Floor Model

MARKET FORGE
 INDUSTRIES INC.

PRINTED IN U. S. A.

 35 Garvey Street • Everett • MA • 02149
 Tel: (617) 387-4100 • Fax: 1-800-227-2659 (Ex. MA) • (617) 387-4456 (MA and Overseas)
 E-Mail: CUSTSERV@mfii.com • Website: www.mfii.com

A City Discount