

# DCM-751B\_H-OS

## OPTI-SERVE SERIES

### SANITARY CUBELET ICE MACHINE/DISPENSER

Item # \_\_\_\_\_

Project: \_\_\_\_\_

Qty: \_\_\_\_\_

\*AutoCad available on KCL

DCM-751B\_H-OS

9/13

Item # 13291

#### DIMENSIONS

W x D x H

**DCM-751B\_H-OS**  
34<sup>1/16</sup> x 28<sup>1/2</sup> x 48<sup>1/16</sup>

**SD-700**  
34<sup>1/4</sup> x 28<sup>1/4</sup> x 32<sup>1/2</sup>

**SD-750**  
34 x 28 x 32<sup>3/4</sup>

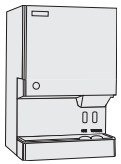

DCM-751  
Countertop

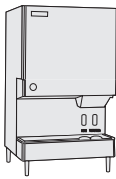

DCM-751  
Countertop  
with optional  
6" legs

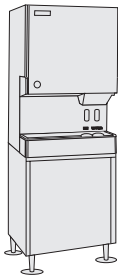

DCM-751  
Floor Model  
with optional  
stand

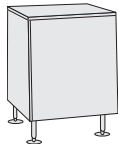

SD-700  
optional  
stand



SD-750  
optional  
stand

#### DCM-751BAH-OS

Air-Cooled  
Shown on an optional  
**SD-750 Stand**



#### DCM-751BWH-OS

Water-Cooled



\*Transparent drinkware may affect dispensing operations

#### DCM-751B\_H-OS

- CleanCycle12® - Every 12 hours, unit performs 15 minute purge to rid itself of impurities 
- LED Remote sensor for hands-free operation
- Sealed LED housing prevents moisture from entering, eliminating the possibility of an electrical short
- Corrosion resistant stainless steel exterior
- Up to 801 lbs. of ice production per 24 hours, with 95 lbs. built-in storage
- Easy to chew, cubelet ice
- Self contained design reducing opportunities for cross contamination
- Dispenses ice and water
- Removable air filters (Air-cooled model only)
- Protected by H-GUARD Plus Antimicrobial Agent 

#### SD-700 Stand / SD-750 Stand

- Heavy duty stand for floor model icemaker/dispenser
- Corrosion resistant stainless steel exterior
- Easy cleaning with attractive appearance
- Locking doors standard on SD-750

#### Warranty

Valid in United States, Canada, Puerto Rico, & U.S. Territories. Contact factory for warranty in other countries.

**Three Year** - Parts & Labor on entire machine. (Serial numbers Vxxxxx) and after.)

**Five Year** - Parts on: Compressor, air-cooled condenser.



ISO9001-ISO14001



# DCM-75IB\_H-OS SANITARY CUBELET ICE MACHINE/DISPENSER - OPTI-SERVE SERIES

## DIMENSIONS

W x D x H

**DCM-75IB\_H-OS**  
34<sup>1/16</sup>" x 28<sup>1/2</sup>" x 48<sup>1/16</sup>"

**SD-700**  
34<sup>1/4</sup>" x 28<sup>1/4</sup>" x 32<sup>1/2</sup>"

**SD-750**  
34" x 28" x 32<sup>3/4</sup>"

- Hands-free ice machine/dispenser
- Optional stand
- Optional stand with locking doors

## AIR-COOLED

Water Temp° F.	50°	70°	90°
Air Temp° F. 70°	801	757	725
Air Temp° F. 80°	695	666	639
Air Temp° F. 90°	612	<b>583</b>	562

## WATER-COOLED

Water Temp° F.	50°	70°	90°
Air Temp° F. 70°	800	779	758
Air Temp° F. 80°	738	719	700
Air Temp° F. 90°	681	<b>685</b>	646

## UTILITY CONSUMPTION

Model Number	KWH per 100 LBS. 90/70	Potable Water Gal. per 100 lbs.
DCM-751BAH-OS	5.94	12.0
DCM-751BWH-OS	4.77	12.0

## SPECIFICATIONS

Model Number	Condenser	Min. Circuit Ampacity	Shipping Weight
DCM-751BAH-OS	Air-Cooled	20	345 lbs.
DCM-751BWH-OS	Water-Cooled	20	345 lbs.
SD-700	N/A	N/A	165 lbs.
SD-750	N/A	N/A	125 lbs.

## \*CUBELET DIMENSIONS

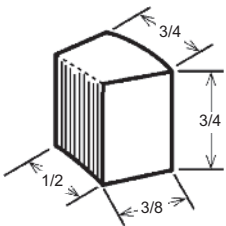

\*approximate size in inches, image not to scale

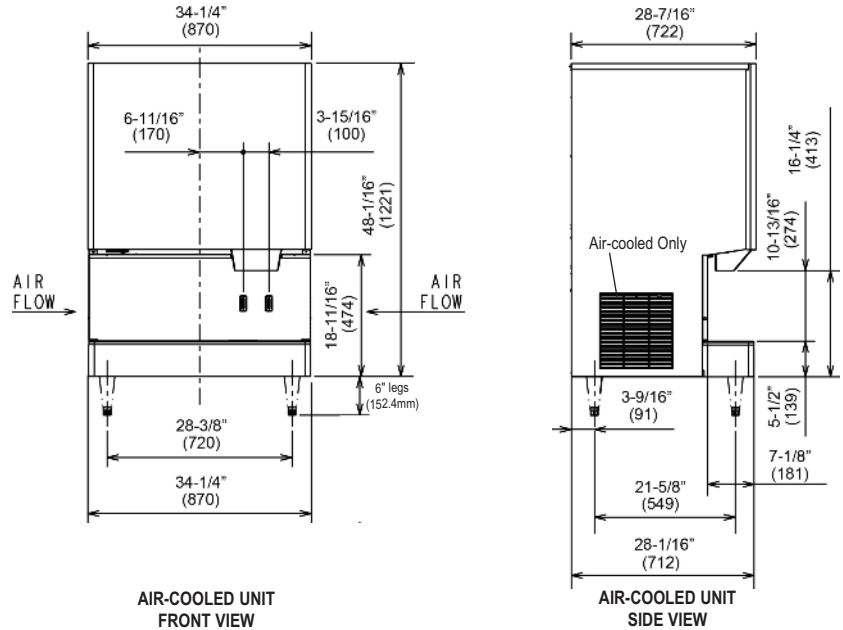

ELECTRICAL SUPPLY  
7/8" DIA. OPENING

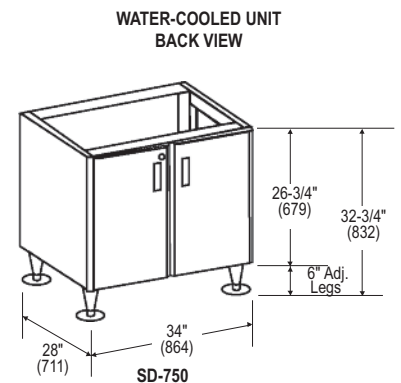
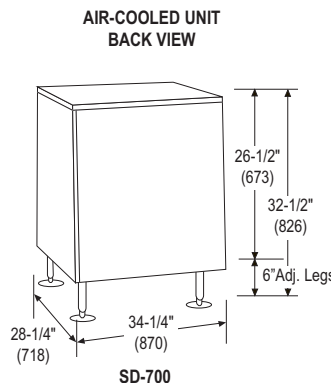
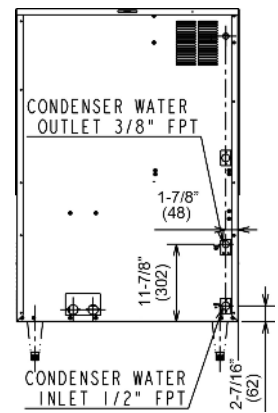
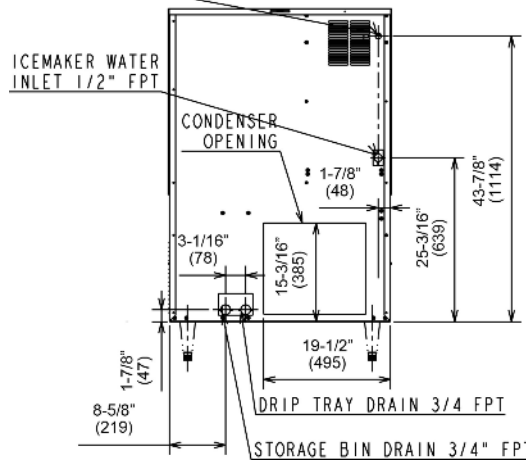

## ELECTRICAL & PLUMBING/DCM-75IB\_H-OS

- 115V/60/1
- 20 amp Max Fuse Size
- 1/2" OD copper or equivalent independent water supply
- 3/4" independent drain connection

## OPERATING LIMITS

- Ambient Temp Range 45 - 100°F
- Water Temp Range 45 - 90°F
- Water Pressure 10 - 113psig
- Voltage Range 104 - 127V

## SERVICE

- Panels easily removed and all components accessible for service.
- Removable/cleanable air filter.



© HOSHIZAKI AMERICA, INC.

618 Hwy. 74 S., Peachtree City, GA 30269

TEL 1-800-438-6087

FAX 1-800-345-1325

www.hoshizaki.com

Printed in U.S.A.

