



Logix2 Series

hotLOGIX HEATED HOLDING & PROOFING CABINETS

(non-insulated aluminum with mechanical controls)

CARTER-HOFFMANN



FOOD SERVICE EQUIPMENT
HUMIDIFIED HOLDING CABINETS

SPECIFICATIONS

Printed in U.S.A. E72 1110
Carter-Hoffmann is a trademark
of Carter-Hoffmann LLC

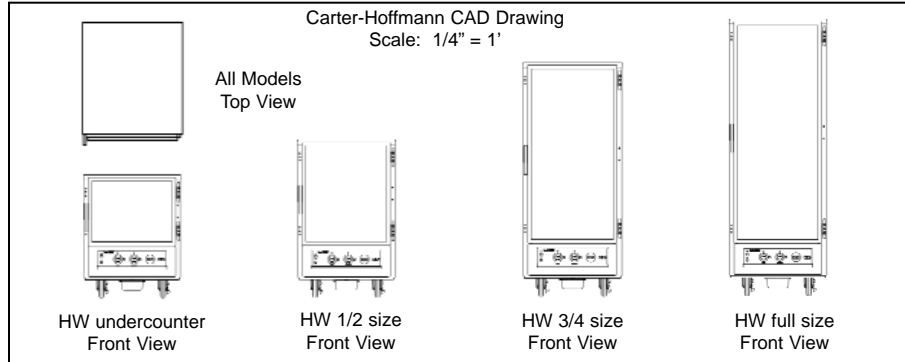

Model Number	Pan/Tray Capacity		Spacing		Inside Working Height		Overall Dimensions						Caster Diameter		Shipping Weight	
	12"x20"	18"x26"	in	mm	in	mm	Height		Depth		Width		in	mm	lbs	kg
							in	mm	in	mm	in	mm				
<input type="checkbox"/> HWU5A2GM	10	5	3	76	15 ⁵ / ₁₆	389	31 ¹ / ₁₆	789	29 ¹ / ₂	749	24 ¹¹ / ₁₆	627	5	127	108	49
<input type="checkbox"/> HWC10A2GM	-	10	1 ¹ / ₂	38	15 ⁵ / ₁₆	389	31 ¹ / ₁₆	789	29 ¹ / ₂	749	24 ¹¹ / ₁₆	627	5	127	95	43
<input type="checkbox"/> HWF5A2GM	10	5	3	76	15 ⁵ / ₁₆	389	31 ¹ / ₁₆	789	29 ¹ / ₂	749	24 ¹¹ / ₁₆	627	5	127	99	45
<input type="checkbox"/> HWU8A2GM	16	8	3	76	24 ⁵ / ₁₆	634	40 ¹ / ₁₆	1018	29 ¹ / ₂	749	24 ¹¹ / ₁₆	627	5	127	149	68
<input type="checkbox"/> HWC16A2GM	-	16	1 ¹ / ₂	38	24 ⁵ / ₁₆	634	40 ¹ / ₁₆	1018	29 ¹ / ₂	749	24 ¹¹ / ₁₆	627	5	127	131	59
<input type="checkbox"/> HWF8A2GM	16	8	3	76	24 ⁵ / ₁₆	634	40 ¹ / ₁₆	1018	29 ¹ / ₂	749	24 ¹¹ / ₁₆	627	5	127	137	62
<input type="checkbox"/> HWU14A2GM	28	14	3	76	44	1118	58 ¹ / ₁₆	1474	29 ¹ / ₂	749	24 ¹¹ / ₁₆	627	5	127	168	76
<input type="checkbox"/> HWC28A2GM	-	28	1 ¹ / ₂	38	44	1118	58 ¹ / ₁₆	1474	29 ¹ / ₂	749	24 ¹¹ / ₁₆	627	5	127	148	67
<input type="checkbox"/> HWF14A2GM	28	14	3	76	44	1118	58 ¹ / ₁₆	1474	29 ¹ / ₂	749	24 ¹¹ / ₁₆	627	5	127	155	70
<input type="checkbox"/> HWU18A2GM	36	18	3	76	54 ¹ / ₂	1384	70 ¹ / ₁₆	1780	29 ¹ / ₂	749	24 ¹¹ / ₁₆	627	5	127	215	97
<input type="checkbox"/> HWC36A2GM	-	36	1 ¹ / ₂	38	54 ¹ / ₂	1384	70 ¹ / ₁₆	1780	29 ¹ / ₂	749	24 ¹¹ / ₁₆	627	5	127	185	84
<input type="checkbox"/> HWF18A2GM	36	18	3	76	54 ¹ / ₂	1384	70 ¹ / ₁₆	1780	29 ¹ / ₂	749	24 ¹¹ / ₁₆	627	5	127	198	90

CONSTRUCTION...Welded & riveted single wall, non-insulated cabinet construction with cabinet welded to base.

CABINET MATERIAL...All aluminum interior and exterior double wall, insulated construction; .063 aluminum exterior with 2V finish.

BASE FRAME... .125 natural aluminum

CASTERS...5" diameter casters with rubber tread. Four swivel casters. Two casters fitted with brakes.

DOOR...Single panel tempered glass door set in extruded aluminum frame. Field reversible. Drip trough at base of door. High temperature silicone gasket mounted to door.

DRIP TROUGH... Full width aluminum drip trough with 1/2" diameter drain located in center. Located at base of cabinet. Includes plastic catch pan.

HINGES...Adjustable edge mount hinges with chrome plate finish.

LATCH...Heavy-duty edge mount latch with magnetic catch.

TRAY RACK ASSEMBLIES... Three slide styles with removable assemblies.

HWU: Universal 16 gauge stainless steel slides, removable and fully adjustable at 1-1/2" spacing. Standard spacing at 3" centers. Hold 18"x26" sheet pans, 12"x20" steam table pans, 2/1 or 1/2 GN pans.

HWF: Universal wire slide at fixed spacing of 3". Assemblies removable. Hold 18"x26" sheet pans, 12"x20" steam table pans, 2/1 or 1/2 G/N pans

HWC: Fixed stainless steel angle slides on 1-1/2" centers hold 18"x26" sheet pans.

THERMOMETER...Digital thermometer with remote sensing bulb and sensing bulb protector. Displays temperature in one degree increments.

CONTROLS...Dial type controls. One dial for heat and one dial for humidity level. Set temperature dial at 3 and humidity dial at 7+ for proofing (approximate temperature of 85°-100°F and 90-95% humidity).

Specifications subject to change through product improvement & innovation.

WATER RESERVOIR...Bottom mounted stainless steel water reservoir is part of heater assembly. Element mounted below pan to provide active humidification. Manual fill. Capacity 2.5 quarts.

HEAT & HUMIDITY SYSTEM...Bottom mounted heater with one 1700 watt coiled incoloy-sheathed heating element. High impedance protected fan motor. Water reservoir with 350 watt element affixed to bottom. Blower fan circulates air and humidity. Full range thermostat and on/off switch with power indicating light. Separate dial controls for heat and humidity.

ELECTRICAL CHARACTERISTICS... Operates on 120 volts, 60 cycle, single phase, 2100 watts, 17.5 amps. Eight foot rubber cord with 3 prong grounding plug. NEMA 5-20P.

PERFORMANCE...Capable of heating to 190°F (88°C). Preheat to 160°F (71°C) in approximately 20 minutes. 95% maximum relative humidity.

ACCESSORIES/OPTIONS...

- Menu card holder (solid door units only)
- Solid aluminum door with black anodized finish on interior and exterior-replace "G" with "X" in model number
- Extra slide pairs (HWU units only)



FEATURES & BENEFITS

1551 McCormick Avenue, Mundelein, Illinois 60060
 Tel. (847) 362-5500 • (800) 323-9793 • Fax (847) 367-8981
www.carter-hoffmann.com



PRECISION ENGINEERED ACTIVE HEAT & HUMIDITY SYSTEM... Heat duct provides even and efficient heating throughout the entire cabinet for safe and consistent results. Quick heat and humidity recovery. Proofing and holding can be accomplished in one cabinet. Unit provides full power to both heating and humidity elements regardless of whether you are holding or proofing.

DRIP TROUGH... Located at base of cabinet to catch condensation. Drain hole in center. Plastic drip pan below trough (provided) to catch condensation.



HWF18A2GM
(full size cabinet)

FIELD REVERSIBLE DOOR(S)... Single pane tempered glass door for easy viewing of cabinet contents, with magnetic door latch and heavy-duty hinges. Full perimeter silicone gasket attached to door for best seal.

FOUR SIZES... Logix2 series cabinets are available in under-counter (31-1/16" high), 1/2 size (40-1/16" high), 3/4 size (58-1/16" high) and full size (70-1/16" high).

EASY-TO-USE DIAL CONTROLS... From proofing to holding, control heat and humidity with separate analog dials and master on/off switch. Temperature range of 85°F to 190°F. Easy to read digital thermometer and recessed control dials, angled for easier reach. Proofing and holding capability in single cabinet. Cabinet can be operated without humidity.



THREE SLIDE STYLES... with removable assemblies.

HWU: Universal 16 gauge stainless steel slides, removable and fully adjustable at 1-1/2" spacing. Standard spacing at 3" centers. Hold 18"x26" sheet pans, 12"x20" steam table pans, 2/1 or 1/2 GN pans.

HWF: Universal wire slide at fixed spacing of 3". Assemblies removable. Hold 18"x26" sheet pans, 12"x20" steam table pans, 2/1 or 1/2 G/N pans

HWC: Fixed stainless steel angle slides on 1-1/2" centers hold 18"x26" sheet pans.



HWC fixed angle slides



HWU adjustable universal slides



HWF fixed universal wire slides

