

# HOSHIZAKI

DCM-750B\_H-OS/SD700  
Item # 13150 7/03

**DCM-750B\_H-OS/SD-700 SERIES**

**SANITARY CUBELET OPTISERVE ICEMAKER/DISPENSER**

**DCM-750BAH-OS**  
(OptiServe Dispenser)  
Air-Cooled

**DCM-750BWH-OS**  
(OptiServe Dispenser)  
Water-Cooled  
**SD-700**  
(Optional Stand)  
For DCM-750



**DCM-750BAH-OS**  
on an  
optional SD-700 stand

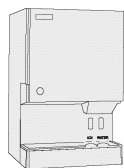

**DCM-750**  
Countertop

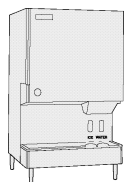

**DCM-750**  
Countertop with  
optional 6" legs

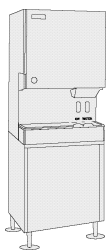

**DCM-750**  
Floor Model with  
optional stand

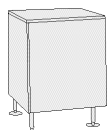

**SD-700**  
Optional stand

**DIMENSION  
BY BIN SIZE**

Width x Depth x Height

**DCM-750 w/o legs**  
34 1/16 x 28 1/2 x 48 1/16

**DCM-750 w/ legs\***  
34 1/16 x 28 1/2 x 54 1/16

**DCM-750 w/ stand\***  
34 1/16 x 28 1/2 x 80 1/2

**SD-700 Stand**  
34 1/4 x 28 1/4 x 32 1/2

\* Optional Items

**DCM-750B\_H-OS**



- CleanCycle 12® - Every 12 hours unit performs a 15-minute purge to rid itself of impurities
- LED Remote sensor for hands-free operation
- Corrosion resistant stainless steel exterior
- Hands-free operation reduces the risk of second-hand contamination
- Completely sealed LED housing, reduces the possibility of electrical short caused by moisture
- Up to 803 lbs. of ice production per 24 hours, with 95 lbs. built-in storage
- Dispenses ice and water
- Self contained design reduces opportunities for cross contamination
- Easy to chew, cubelet ice
- Removable air filters (air cooled models only)

**SD-700 Stand**

- Heavy duty stand for floor model icemaker/dispenser
- Corrosion resistant stainless steel exterior
- Easy cleaning with attractive appearance



Reliability is a beautiful thing™

© HOSHIZAKI AMERICA, INC.

618 Hwy. 74 S., Peachtree City, GA30269

1-800-438-6087

FAX 1-800-345-1325

TEL 770-487-2331

www.hoshizaki.com

# DCM750B\_H-OS/SD-700 SERIES

# DIMENSIONS (Inches) - CONNECTIONS

## SANITARY CUBELET OPTISERVE ICEMAKER/DISPENSER

DCM-750BAH-OS (AIR-COOLED)  
 DCM-750BWH-OS (WATER-COOLED)  
 SD-700 (OPTIONAL STAND FOR DCM-750)

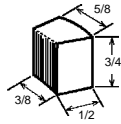

- Up to 803 lbs. of ice production per 24 hours
- 95 lbs. of built-in ice storage
- Dispenses ice and water



<b>WARRANTY</b> TWO YEAR - Parts & labor on entire machine. FIVEYEAR - Parts on: Compressor, Air-Cooled Condenser.	<b>STAINLESS STEEL INTERNAL AUGER</b>	<b>SERVICE</b> Panels easily removed and all components accessible for service. Removable/cleanable air filters.
	<b>R-404 REFRIGERANT</b>	

Warranty valid in United States, Canada, Puerto Rico, & U.S. Territories. Contact Factory for Warranty in other Countries.

<b>OPERATING LIMITS</b> Ambient Temp Range 45 - 100°F Water Temp Range 45 - 90°F Voltage Range 104 - 127V Water Pressure 10 - 113 psig	<b>ELECTRICAL</b> 115/60/1 20 amp Max Fuse Size/HACR Breaker Size	<b>STORAGE BIN</b> Built-in 95 lb. capacity	<b>FUSE &amp; THERMAL PROTECTOR</b> - prevents gear from overloading
<b>Clean Cycle 12*</b> : 15 minute purge every 12 hours		<b>MACHINE STAND</b> Optional SD-700	<b>GEAR MOTOR</b> - runs one minute after termination of icemaking to clear all ice from evaporator

AIR - COOLED				
Water Temp ° F.	50°	70°	90°	
Air Temp ° F.	70°	803	770	726
80°	684	645	608	
90°	573	<b>567</b>	509	

UTILITY CONSUMPTION				
Model Number	Approximate Electrical		KWH per 100 lbs.	
	90/70	70/50	90/70	70/50
DCM-750BAH-OS	1481W	1449W	6.3	4.3
DCM-750BWH-OS	1383W	1410W	5.1	4.5

WATER - COOLED				
Water Temp ° F.	50°	70°	90°	
Air Temp ° F.	70°	744	719	708
80°	696	684	673	
90°	662	<b>654</b>	640	

SPECIFICATIONS				
Model Number	Condenser	Amperage	Min Circuit Ampacity	Shipping Weight
DCM-750BAH-OS	Air-Cooled	20.4	20	405 lbs.
DCM-750BWH-OS	Water-Cooled	16.3	20	405 lbs.
SD-700	N/A	N/A	N/A	145 lbs.

Separate ICE and WATER Dispensing

Convenient variable Cubelet portion control is adjustable to select right amount of ice for container being used. For high volume, control may be set to continuous operation with a 60 second time out.

Flaked Ice compacted into Cubelets by extruding head cutter and stored in an insulated bin with continuous agitation during dispensing

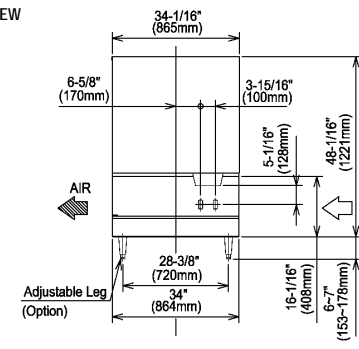
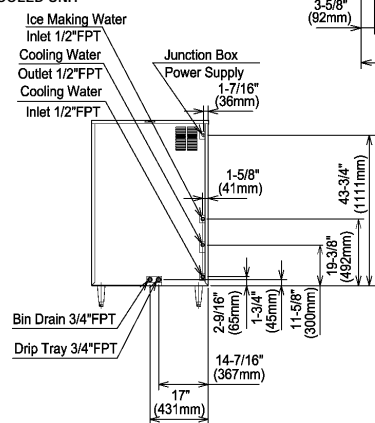
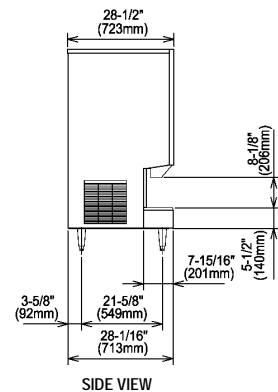
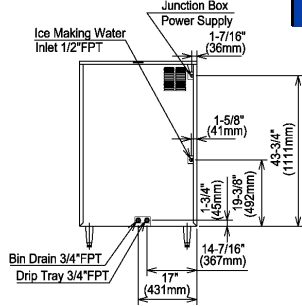
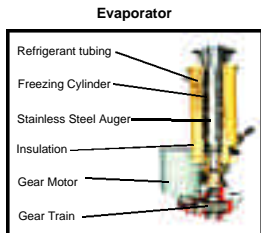

We reserve the right to change specifications without notice.

© HOSHIZAKI AMERICA, INC.