

# BERNER PATIO HEATERS Floor Mount Parasol

*****Permanent Models		
<u>SPECIFICATIONS</u>	<u>MODEL BPP-E301</u>	<u>MODEL BPT-E301</u>
Volts	24 VAC	24 VAC
Amps	0.8	0.8
Control	Two-Stage Switch, Direct Spark	Two-Stage Switch, Direct Spark
Fuel	NG or LPG	NG or LPG
Operating Pressure NG	Min 6.5" W.C Max 14" W.C	Min 6.5" W.C Max 16" W.C
Operating Pressure LPG	Min 10.8" W.C Max 14" W.C	Min 10.8" W.C Max 14" W.C
High Fire NG	*53,000 BTU/H	*53,000 BTU/H
Low Fire NG	*46,000 BTU/H	*46,000 BTU/H
High Fire LPG	*47,000 BTU/H	*47,000 BTU/H
Low Fire LPG	*40,000 BTU/H	*40,000 BTU/H
Mounting Options	Vertical Pole	Overhead Suspension
Effective Range	*12' to 24' Radius	*12' to 24' Radius
Distance	*14' to 20' apart	*14' to 20' apart

## \*TYPICAL COVERAGE

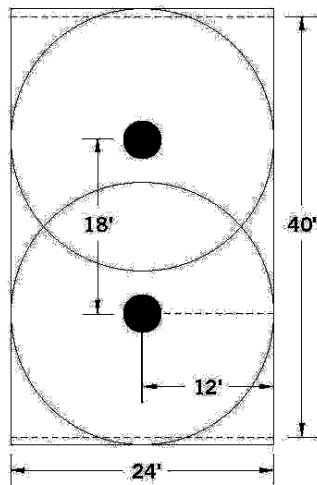

\*Note: Ambient temperatures and wind conditions vary and will affect heater performance. To maximize layout distances, employ building walls, alcoves, fences and shrubbery lines as wind barriers.

## WARRANTY

- *Emitter and Burner = 5 years*
- *Parts and Components = 3 years*

## SIZE

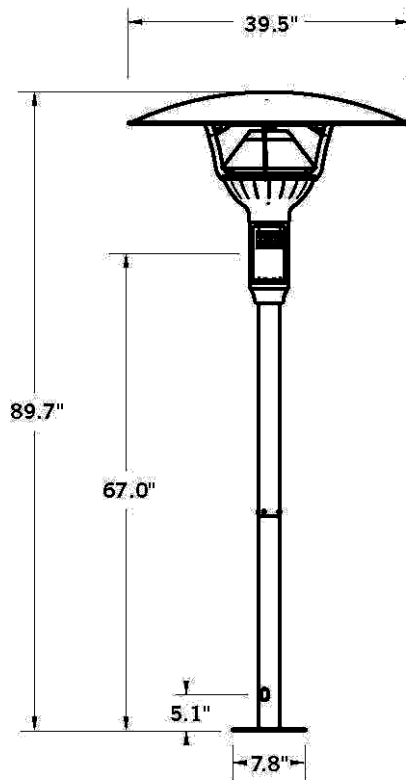

## CLEARANCE TO COMBUSTIBLES

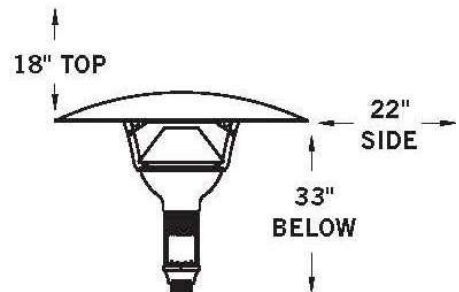

## HANGING DIMENSIONS

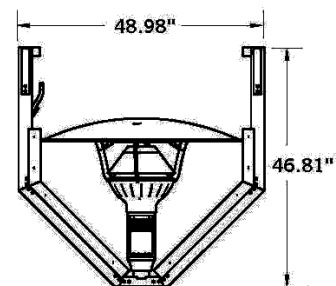

# BERNER PATIO HEATERS Portable Parasol

<b>Portable Models</b>		
<b>SPECIFICATIONS</b>	<b>DRR/G423RO U5</b>	<b>DRR/423RO D</b>
Finish	304 S/S	Powder Coated Black
Gas Manifold Pressure	11" W.C	11" W.C
Max. Inlet Gas Supply Pressure	250psi	250psi
Control	AA Battery 'Piezo' Ignition	AA Battery 'Piezo' Ignition
Fuel	LPG	LPG
Variable Fire Rate (max)	*46,000 BTU/H	*46,000 BTU/H
Wood & Concrete Securable	Yes	Yes
Wheels	Included	Included
Beverage / Food Tray	Optional	Optional
Weight	120lbs (without tank)	120lbs (without tank)
Effective Range	*12' to 24' Radius	*12' to 24' Radius
Distance	*14' to 20' apart	*14' to 20' apart

## \*TYPICAL COVERAGE

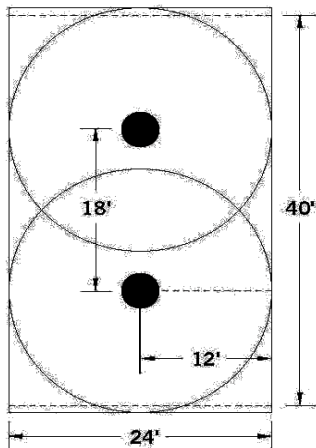

\*Note: Ambient temperatures and wind conditions vary and will affect heater performance. To maximize layout distances, employ building walls, alcoves, fences and shrubbery lines as wind barriers.

## WARRANTY

- *Emitter and Burner = 5 years*
- *All other parts = 1 year*

## SIZE

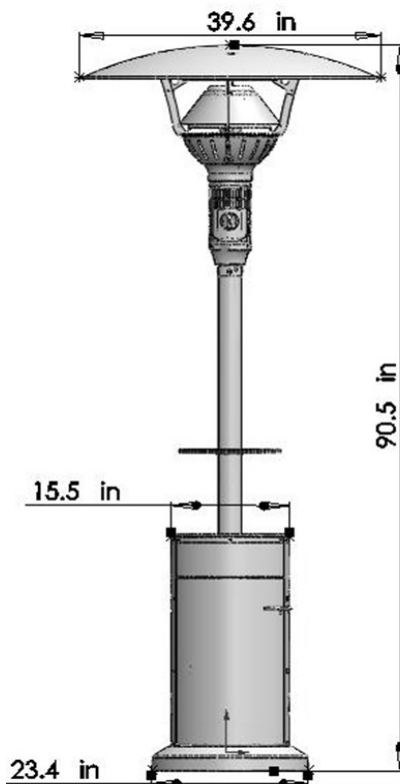

## CLEARANCE TO COMBUSTIBLES

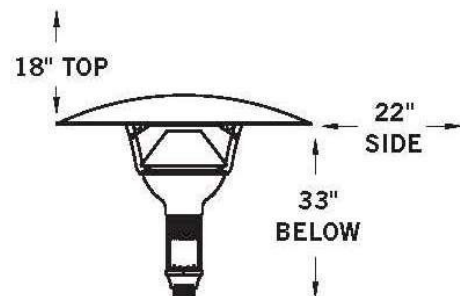

## BALL BEARING WHEELS

