



Profit from the Eagle Advantage®

# Specification Sheet

## Short Form Specifications

Eagle Hot Food Tables, open base design, model \_\_\_\_\_ . Top and body to be heavy gauge type 430 stainless steel. Beaded top openings to be 12 3/32" x 20 3/32". Heating compartments to be 8"-deep, galvanized, and insulated on all four sides and bottom with 1" fiberglass or equal. Recessed control panel with individual infinite controls offer high and low settings. Each compartment fitted with 500-watt heating element for 120-volt units, and 750-watt heating element for 240-volt units. Six foot cord and plug extends from the bottom right hand side of the unit. Furnished with polycarbonate cutting board. Legs to be 1 1/2" O.D. tubing, with adjustable undershelf and 4"-diameter casters.



#PDHT4-120 portable hot food table

## Options / Accessories

- Spillage pans
- Bolted-in undershelf
- Overshelves
- Tray slides
- Tray shelf
- Dish shelf
- Rolltop cover
- Hardwood cutting board

\* See Catalog Sheet #EG30.18 for more information on Flex-Master® overshelves

## EAGLE GROUP

100 Industrial Boulevard, Clayton, DE 19938-8903 USA  
Phone: 302-653-3000 • Fax: 302-653-2065  
www.eaglegrp.com

Foodservice Division: Phone 800-441-8440  
MHC/Retail Display Divisions: Phone 800-637-5100

For custom configuration or fabrication needs, contact our SpecFAB® Division.  
Phone: 302-653-3000 • Fax: 302-653-3091 • e-mail: specfab@eaglegrp.com

Spec sheets available for viewing, printing or downloading from our online literature library at [www.eaglegrp.com](http://www.eaglegrp.com)

Eagle Foodservice Equipment, Eagle MHC, SpecFAB®, and Retail Display are divisions of Eagle Group. ©2011 by the Eagle Group

A City Discount

Item No.: \_\_\_\_\_  
 Project No.: \_\_\_\_\_  
 S.I.S. No.: \_\_\_\_\_

# Electric Hot Food Tables— Open Base, Portable

## MODELS:

- PDHT2-120
- PDHT2-240\*
- PDHT3-120
- PDHT3-240\*
- PDHT4-120
- PDHT4-240\*
- PDHT5-240\*
- SPDHT2-120
- SPDHT2-240\*
- SPDHT3-120
- SPDHT3-240\*
- SPDHT4-120
- SPDHT4-240\*
- SPDHT5-240\*

\* These units are available in three-phase. To order, add suffix "-3". Ex: PDHT3-240-3

## Construction

- Table body and top are constructed of highly polished 22 gauge 430 series stainless steel.
- Top features die stamped beaded openings measuring 12 3/32" x 20 3/32" (307 x 510mm).
- A poly cutting board, 8" (203mm) wide and 1/2" (13mm) thick, is mounted on drop brackets located on control side of unit, allowing movement through standard doorway.
- Legs are 1 1/2" (41mm) O.D. tubing fitted with 4" (102mm) diameter NSF certified ball-bearing casters.
- All models are 30 1/2" (774mm) wide and 34" (863mm) high.
- Units feature 1" (25mm)-wide push bar attached to the end panel at operator's right.

## Controls

- Individual infinite controls offer high and low selections along with eight other temperature settings.
- Indicator light remains on continuously while control is in "ON" position.

## Heat compartments

- Each heat compartment is 8" (203mm) deep and lined with 22 gauge galvanized steel.
- Each compartment is insulated on all four sides and bottom with 1" (25mm) thick fiberglass or equal.

## Electrical

- Each compartment is fitted with a 500-watt or 750-watt tubular element above the insulated bottom. 500-watt element is standard on units wired for 110-120 volts; 750-watt element is standard for units wired for 220-240 volts.
- A six-foot (1829mm) cord with plug extends from the bottom of the right hand control side as standard equipment.
- 120-volt models are single phase. 240-volt models available in single- or three-phase.

## Certifications / Approvals



New York MEA 376-84-E

## AUTOQUOTES



EG30.01 Rev. 06/11



Item No.: \_\_\_\_\_  
 Project No.: \_\_\_\_\_  
 S.I.S. No.: \_\_\_\_\_

## Electric Hot Food Tables—Open Base, Portable

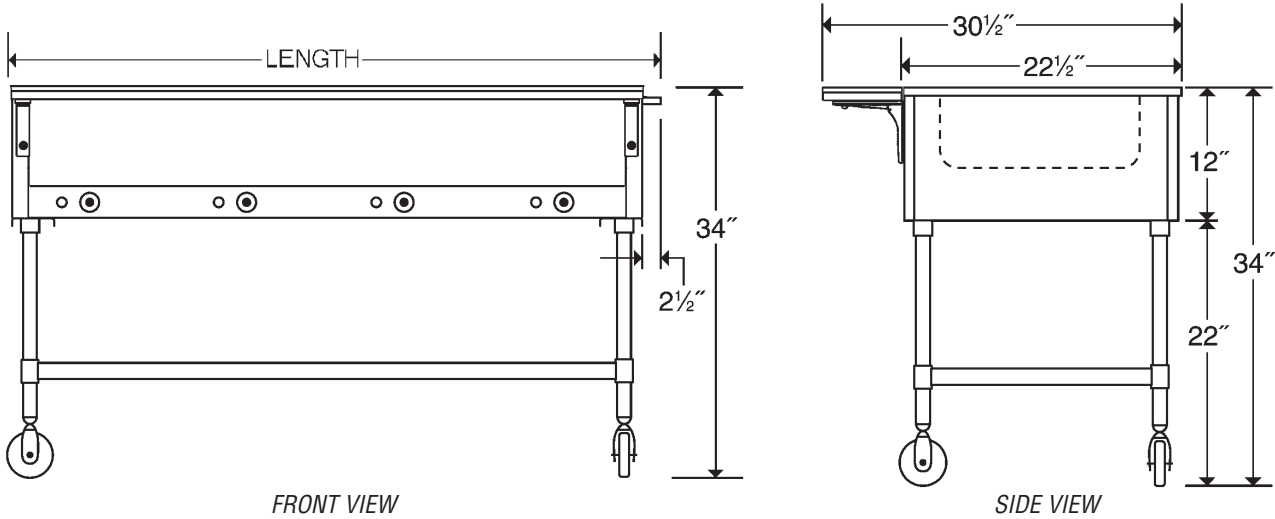

SINGLE-PHASE		THREE-PHASE		# of openings	electrical data	length		weight	
WITH GALVANIZED LEGS & UNDERSHELF	WITH STAINLESS STEEL LEGS & UNDERSHELF	WITH GALVANIZED LEGS & UNDERSHELF	WITH STAINLESS STEEL LEGS & UNDERSHELF			in.	mm	lbs.	kg
PDHT2-120	SPDHT2-120	n/a	n/a	2	1000W, 120V	35½"	902	101	45.8
PDHT2-240	SPDHT2-240	PDHT2-240-3	SPDHT2-240-3	2	1500W, 240V	35½"	902	101	45.8
PDHT3-120	SPDHT3-120	n/a	n/a	3	1500W, 120V	50½"	1283	129	58.5
PDHT3-240	SPDHT3-240	PDHT3-240-3	SPDHT3-240-3	3	2250W, 240V	50½"	1283	129	58.5
PDHT4-120	SPDHT4-120	n/a	n/a	4	2000W, 120V	66"	1676	162	73.5
PDHT4-240	SPDHT4-240	PDHT4-240-3	SPDHT4-240-3	4	3000W, 240V	66"	1676	162	73.5
PDHT5-240	SPDHT5-240	PDHT5-240-3	SPDHT5-240-3	5	3750W, 240V	81½"	2070	199	90.3

Note: 240-volt units also available in 208 volt. To order, replace suffix "-240" with suffix "-208". Example: PDHT3-208

### RECEPTACLE CONFIGURATIONS REQUIRED

15A 125V	15A 250V	20A 250V	30A 250V	30A 125V	20A 3Ø 250V
model # (S)PDHT2-120 (S)PDHT3-120	model # (S)PDHT2-240 (S)PDHT3-240	model # (S)PDHT4-240	model # (S)PDHT5-240	model # (S)PDHT4-120	all three-phase models
furnished with NEMA 5-15 plug	furnished with NEMA 6-15 plug	furnished with NEMA 6-20 plug	furnished with NEMA 6-30 plug	furnished with NEMA 5-30 plug	furnished with NEMA 15-20 plug

### FLEX-MASTER® Overshelf Kits

Both kits include two 16/304 overshelves and four 30" (762mm) posts. Add suffix specified to order kit (example: DHT2-120-FMU), or design your own using standard components from EG30.18.

description	add suffix
10" (254mm) overshelves	-FM
15" (381mm) overshelves, plus one ladle rack	-FMU

**EAGLE GROUP**  
 100 Industrial Boulevard, Clayton, DE 19938-8903 USA  
 Phone: 302-653-3000 • Fax: 302-653-2065  
 www.eaglegrp.com

Foodservice Division: Phone 800-441-8440  
 MHC/Retail Display Divisions: Phone 800-637-5100

Printed in U.S.A.  
 ©2011 by Eagle Group  
 Rev. 06/11

Spec sheets available for viewing, printing or downloading from our online literature library at [www.eaglegrp.com](http://www.eaglegrp.com)

Although every attempt has been made to ensure the accuracy of the information provided, we cannot be held responsible for typographical or printing errors. Information and specifications are subject to change without notice. Please confirm at time of order.