



JOB _____ ITEM # _____

CHAR-BROILER RANGES



Model F3226-18-1.5RB
(shown w/ optional casters & extra racks)



Model F3218-2RB



Standard Features, Benefits & Options

CONSTRUCTION: Easy cleaning, stainless steel finish, sturdily welded with angle iron and corrosion resistant aluminized steel framing. Low back splash is standard. Sturdy 6" stainless steel pipe legs with adjustable feet. Double wall construction with heavy fiberglass insulation assures heat retention for daily money saving fuel efficiency and offers the best installation clearances in the industry. Non-combustible surfaces are 0" on the sides and 0" in the rear, combustible surfaces are 2" on the sides and 2" in the rear.

OVENS: 3 widths from which to choose; 31½", 26½" & 19½" All ovens measure 20½" deep x 14" high. One heavy duty chrome plated wire rack is standard with 3 rack positions spaced approximately 2¾" apart with 5¾" between the top rack position and the ceiling. Easy cleaning porcelain coated and aluminized steel oven linings are standard. The ovens feature a durable cast iron "H" pattern burner; 31½" & 26½" ovens are rated at 30,000 BTUH, the 19½" oven is rated at 25,000 BTUH. A special designed baffle directs heat for superior air circulation. Convection option is available, add prefix "C" to the model number.

BURNERS: 12" incremental griddle & char-broiler models feature cast iron "H" pattern burners, one for each 12" increment; griddles are rated at 20,000 BTU ea. & char-broilers at 25,000 ea. 18" and 30" griddle & char-broiler sections feature 2 and 4 straight burners respectively; griddles are rated at 18,000 BTU ea. & char-broilers at 20,000 ea. Open burners are cast iron without gaskets, rated at 24,000 BTU's and feature a large 7" "star" flame pattern.

OPEN TOP GRATES: Open burner grates are 12" x 12" solid cast iron with spillover bowl that also reflects heat to the cooking surface for added efficiency and designed for easy movement of pots across top sections.

GRIDDLE PLATE: Highly polished to minimize food sticking. ¾" thick plate is standard, 1" thick is available. 4" high splash guard is standard. Higher sides are also available. 21¼" deep cooking surface with front cold zone grease trough. Grease drain slot is 3.5" x 1" and feeds into a seamless, deep, removable grease drawer.

CHAR-GRATES: Cast iron top grate sections measure 20.5" deep, designed with cast-in grease trough on each blade to allow grease run off into the front cold zone grease trough and reduces flare up. Each section is reversible for sloped or level grilling. Stainless steel splash guards on 3 sides graduating up to 4" high. Grease drain slot is 3.5" x 1" and feeds into a large, removable grease drawer.

RADIANTS: Char-broiler radiants are either lava rock or heavy duty angle iron, inverted "V" type for superior uniform heating temperature. "V" type radiants are easily removable for cleaning.

OPTIONS & ACCESSORIES: High back and shelf, thermostats, 1" thick plates, raised griddle-cheesemelters, safety pilots, grill scrapers, spatulas, cleaning supplies, chrome plating, safety pilot controls, gas hoses, carrying handles, knob protectors and matching equipment stands.



Comstock-Castle Stove Co. • 119 W. Washington St. • Quincy, IL. 62301
Tel.: 217-223-5070 • Fax: 217-223-0007 • www.castlestove.com



CHAR-BROILER RANGES MEASUREMENTS

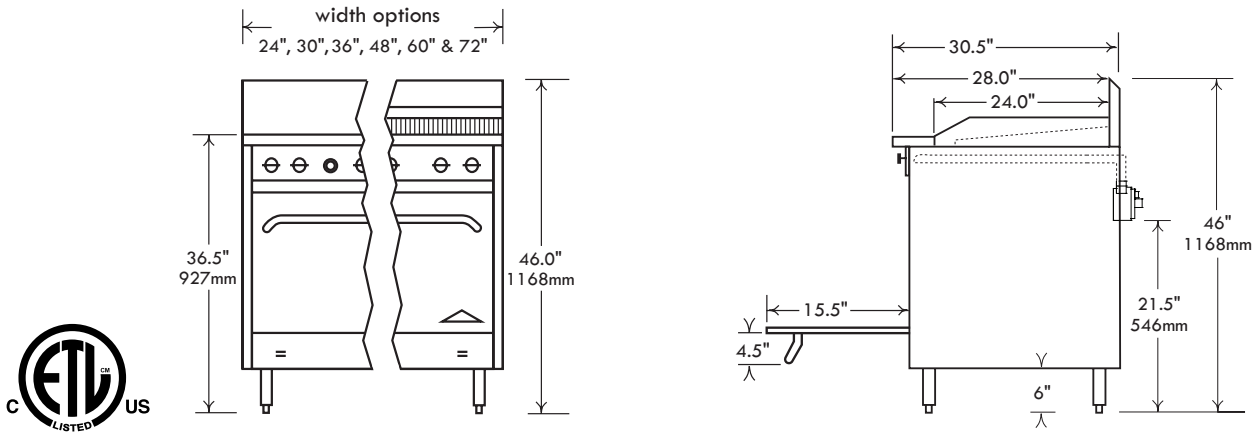

Char-Broiler Ranges (Popular models shown below. Call factory for other model details.)

Cooktop Configuration	Model #	Description		Total B.T.U.	Approx. Wgt. Kg. / Lbs.
		Top	Base		
	F318-2RB	(0) Open Burners	- w/ (1) 19.5" Oven	75,000	173 / 380
	F330-12-1RB	(2) Open Burners & (1) 12" Griddle & (1) 12" Radiant Broiler	- w/ (1) 31.5" Oven	123,000	225 / 560
	F330-18-1.5RB	(0) Open Burners & (1) 18" Griddle & (1) 18" Radiant Broiler	- w/ (1) 31.5" Oven	106,000	264 / 580
	F3218-2RB	(4) Open Burners & (1) 24" Radiant Broiler	- w/ (2) 19.5" Ovens	196,000	309 / 680
	F3430-2RB	(4) Open Burners & (1) 24" Radiant Broiler	- w/ (1) 31.5" Oven - & 10" storage space	176,000	320 / 705
	F3226-18-1.5RB	(4) Open Burners & (1) 18" Griddle & (1) 18" Radiant Broiler	- w/ (2) 26.5" Ovens	232,000	425 / 935
	F3226-24-1RB	(4) Open Burners & (1) 24" Griddle & (1) 12" Radiant Broiler	- w/ (2) 26.5" Ovens	221,000	427 / 940
	F3226-30-2.5RB	(0) Open Burners & (1) 30" Griddle & (1) 30" Radiant Broiler	- w/ (2) 26.5" Ovens	212,000	468 / 1030
	2F330-30-1.5RB	(4) Open Burners & (1) 30" Griddle & (1) 18" Radiant Broiler	- w/ (2) 31.5" Ovens	268,000	532 / 1170

Raised griddle-cheesemelter-broilers available in lieu of flush griddles.
Char-broiler ranges come standard with low backs to meet sanitation codes.

NOTICE: In an ongoing effort of product development & improvement, Comstock-Castle reserves the right to change specifications and product design without notice. Such modifications do not entitle the buyer to corresponding changes or replacements for previously purchased equipment.