

G**48" HEAVY DUTY GAS RANGE**

JOB NAME: _____

ITEM NO.: _____

NO. REQUIRED: _____

MODEL: R-R8**SIZE:** 48" Wide x 56 1/2" High x 31 1/2" Front-to-Back
(1219mm Wide x 1435mm High x 800mm Front-to-Back)**DESCRIPTION:** The Market Forge R-R8 Heavy Duty Range provides as standard many of the optional upgrades normally offered at a premium on other Range lines. The Convection Oven has the ability to cook with the convection system engaged or for foods that do not require convection.

The Market Forge Heavy Duty Range offers as standard, features that are first in the industry and innovations, such as:

- Cast iron top grates, 12" x 12", for open burners.
- Two piece, heavy duty lift off cast iron burner heads, rated at 30,000 BTU/hr.
- Spill protected standing pilot on each open burner for instant safe ignition.
- 5/8" thick griddle plate, highly polished, with 3" wide grease trough. Griddle on the left is standard.
- Full width removable crumb/drip trays under open burners.

OVEN SPECIFICATIONS:

Constructed of stainless steel front, sides, valve corner and kick plate. Heavy gauge stainless steel plate ledge and 11" deep stainless steel high self on standard back guard with stainless steel splash panel. Frame constructed of heavy duty welded metal. Oven contact surfaces have porcelain finish for easy maintenance. Porcelainized oven interior includes; sides, rear, deck and door linings. Oven doors constructed for heavy use, easily removable for cleaning.

Dual 20" wide ovens are standard. "U" shaped oven burner provides 27,000 BTU/hr. for constant heating. Oven design enhances airflow. Oven safety valve provides 100% shut down if pilot flame goes out. Oven Controls include a piezo type push button (matchless) ignition to light the oven's standing pilot.

Gas Connection:3/4" NPT on the right hand rear of the appliance. The pressure regulator (*supplied*) is to be connected here by the installer.

- Gas Pressure:** Natural Gas - 5" W.C.
 Propane - 10" W.C.

*R-R8 Shown on Optional Casters***OPTIONS AT EXTRA COST:**

- Convection Oven (*add suffix "-C1" to end of model #*).
- Griddle section. Highly polished 3/4" thick plate, 12" or 24" Wide (*see reverse side*).*
- Grooved Griddle Section, 12", 24" or 36" Wide.
- Thermostatic control for the griddle (*3/4" thick plate*).
- Extra Chrome Rack (*One per oven is standard*).
- Casters, 6" High (*Set of 4, 2 with brakes*).
- Storage Cabinet (*in lieu of 20" oven*).
- Shelf, Stainless Steel, 8" Deep x 12" Long.
- Work Surface, 12" Section (*in lieu of burner*).
- Saute or Wok Style Burner Heads.
- Wok Ring, 10"Ø Stainless Steel, (*fits over top grate*).
- French Hot Top Section - 12" wide x 24" deep.
- Splash Guard, Stainless Steel, 6" (*separates open burners, griddle and/or radiant burner sections*).
- Quick Disconnect Gas Hose with Restraining Device.
 - 3/4" NPT x 48" Lg. 3/4" NPT x 60" Lg.
- Flanged Feet.
- Salamander Broiler R-RSB-48.
- Cheesemelter Broiler R-RCM-48.
- Prison Package, (*Consult Factory*).

* *Note: Each 12" of griddle replaces one pair of open burners.*

The manufacturer reserves the right to modify materials and specifications without notice.

SPEC SHEET: S-6132A
04/13FOOD SERVICE EQUIPMENT
Heavy Duty Range**MARKET FORGE**
INDUSTRIES INC.

PRINTED IN U. S. A.

35 Garvey Street • Everett • MA • 02149
Tel: (617) 387-47100 • Fax: 1-800-227-2659 (Ex. MA) • (617) 387-4456 (MA and Overseas)
E-Mail: CUSTSERV@mfi.com • Website: www.mfii.com

A City Discount

G

48" HEAVY DUTY GAS RANGE

DETAILS & DIMENSION

SPEC SHEET: S-6132A
04/13

FOOD SERVICE EQUIPMENT
Heavy Duty Range

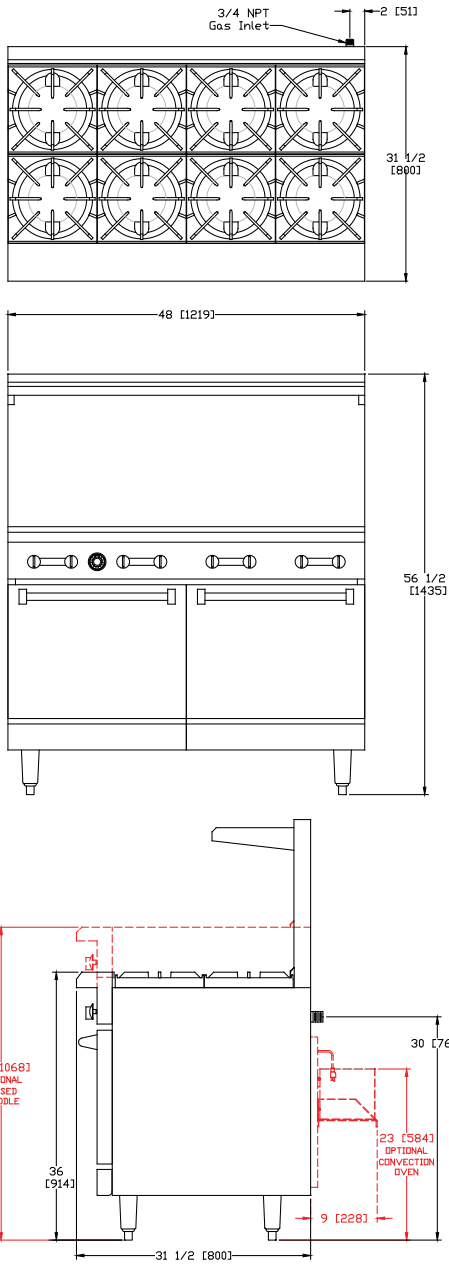

Top Configuration	Burner Option	Total BTU's & Ship Weight
	R-R8 (Standard) (8) Burners (2) 20" Ovens	294,000 800 lbs.
	OPTION 1 R-RG12-6 12" Griddle (6) Burners (2) 20" Ovens	254,000 820 lbs.
	OPTION 2 R-RG24-4 24" Griddle (4) Burners (2) 20" Ovens	214,000 830 lbs.
	OPTION 3 R-RG36-2 36" Griddle (2) Burners (2) 20" Ovens	174,000 850 lbs.
	OPTION 4 R-RG48 48" Griddle (0) Burners (2) 20" Ovens	134,000 870 lbs.
	OPTION 5 R-RRG24-4 24" Raised Griddle (4) Burners (2) 20" Ovens	214,000 910 lbs.

Crated Dimensions: 42" D x 36" H x 50.5" W

Optional Convection Oven Electrical Requirements:

(Add suffix **-C1** to end of model number when ordering optional convection oven in lieu of standard oven)

- 120VAC, 50/60 Hz, 1 Phase
- 8 amps per single oven.
- Two speed motor (1725/1140 RPM) 1/2 HP.
- Provided with a 6' power cord fitted with standard 3-prong grounded plug.

Installation Clearance: When installing against combustible surfaces (*side walls*) is 15" (381mm) and (*rear walls*) is 4" (102mm) clearance is required. When installing against non-combustable surfaces (rear or side walls) 0" clearance is required.

CSA & CSA Certified. NSF Standards.



MARKET FORGE
INDUSTRIES INC.



PRINTED IN U. S. A.

35 Garvey Street • Everett • MA • 02149
Tel: (617) 387-47100 • Fax: 1-800-227-2659 (Ex. MA) • (617) 387-4456 (MA and Overseas)
E-Mail: CUSTSERV@mfi.com • Website: www.mfii.com

A City Discount