



ITEM NO.

SDU50 and SDU90 Shortening Disposal Units

AAA File No. 35-C111

Specifically designed for the removal of waste oil from the kitchen

Frymaster provides the answer for the transportation of waste oil from the kitchen to the disposal container, with shortening disposal units, available in 50- and 90-lb. (23 and 41 kg) capacities. They are made with the following features:

- **Drain height of 9 5/8"** (244 mm) (with cover open) allows unit to fit under most fryers to permit direct draining of fryers into unit or under drain for fryers with built-in filtration system.
- **Low center of gravity** provides stability.
- **Heavy-duty manual pump** can empty 50 lbs. (23 kg) of oil in less than 60 seconds.
- **Pump located at convenient height** -- no stooping or bending required to operate; and there are no hoses to break or be misdirected.
- **Large 7" (178 mm) wheels** provide easy transporting of oil, even across parking lots; and no lifting is necessary.
- **Warranty** -- 90 days parts and labor; pump warranted one year, parts only.
- **SDU50** fits in the FootPrint PRO and most Filter Magic® cabinets to allow easy disposal of used oil.
- **SDU90** fits in MJCF Filter Magic® cabinet to allow easy disposal of used oil.
- Can ship UPS.



ISO 9001:2000



Frymaster, L. L. C.

8700 Line Avenue, P. O. Box 51000, Shreveport, Louisiana 71135-1000, USA Phone 318-865-1711

TOLL FREE 1-800-221-4583 Fax 318-868-5987

Distributed in Canada by GARLAND COMMERCIAL RANGES, LTD., 1177 Kamato, Mississauga, Ontario L4W 1X4

SDU50 and SDU90 Shortening Disposal Units

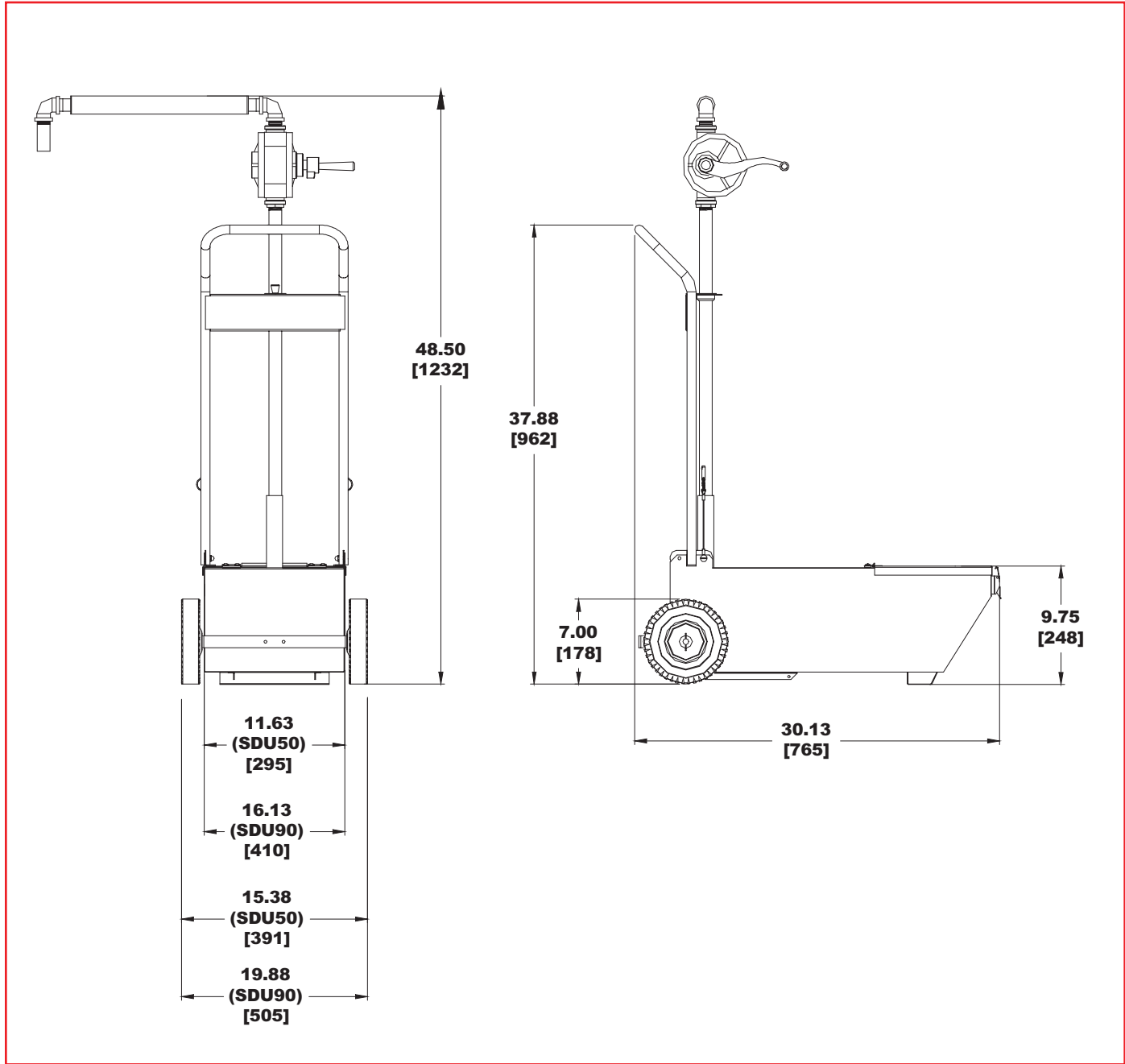

DIMENSIONS -- Inches (mm)

MODEL NO.	SHORTENING CAPACITY	ASSEMBLED SIZE			DRAIN HEIGHT	NET WEIGHT	SHIPPING INFORMATION			SHIPPING DIMENSIONS		
		HEIGHT	WIDTH	LENGTH			WEIGHT	CLASS	CUBE	HEIGHT	WIDTH	LENGTH
SDU50	50 lbs. (23 kg)	48.50" (1232)	15.38" (391)	30.13" (765)	9.62" (244) w/door open	45 lbs. (20 kg)	62 lbs. (28 kg)	85	7	20" (508)	21" (533)	30" (762)
			Overall 11.63" (295) Tank Only									
SDU90	90 lbs (41 kg)	48.50" (1232)	19.88" (505)	30.13" (765)	9.62" (244) w/door open	49 lbs. (22 kg)	67 lbs. (30 kg)	85	10	20" (508)	23" (584)	39" (991)
			Overall 16.13" (410) Tank Only									



Frymaster, L. L. C.

8700 Line Avenue, P. O. Box 51000, Shreveport, Louisiana 71135-1000, USA, Phone 318-865-1711

TOLL FREE 1-800-221-4583 Fax 318-868-5987

Distributed in Canada by GARLAND COMMERCIAL RANGES, LTD., 1177 Kamato, Mississauga, Ontario L4W 1X4