

Anets SilverLine™ Manual Gas Griddle

SLMG Models

Item No.

Anets Introduces A Griddle Designed for Years Of Outstanding Performance

The reliable Anets heavy duty stainless steel construction is ready for your busy kitchen. Dependable manual valves put temperature control in the operators hands. Convenient viewing ports enable the user to see the burner flame for straight forward flame control. The standing pilot ignition system is easily accessible through individual access points. One U-shaped burner for every foot of griddle width provides even heat distribution across entire griddle surface and heat zone control. Available in a variety of sizes. Get Anets quality at an affordable price, the Anets manually controlled griddle.

STANDARD FEATURES

- High nickel content 3/4" precision ground hot rolled steel plate
- One burner per foot: 30,000 BTUH per burner
- Stainless steel front, sides, grease trough, and splashguards
- No electrical connections required
- Extra large grease chute opening
- Large capacity 5.7 quart grease drawer easily accessible under cabinet and is equipped with anti-splash guards
- Double wall construction keeps the operator and kitchen cool
- Equipped with an easy to reach main gas shut-off valve



**SLMG 24x36 shown
optional stainless steel stand with
undershelf and casters**

ANETS
SilverLINE™



ANETS

Anetsberger Brothers, Inc. ■ Dependable Foodservice Equipment
180 North Anets Drive ■ Northbrook, Illinois 60062
1-800-837-2638 ■ Fax 847-272-1943 ■ www.anets.us

Anets SilverLine™ Manual Gas Griddle

SLMG Models



SPECIFICATIONS

- Model SLMG Models (See chart below)
- Certification ETL, CETL
- BTUH input 30,000 per burner (foot),
NG 4" WC, LP 10" WC,
Pressure regulator included
- Gas Supply Pressure 3/4" NPT
- Gas Connection None
- Electrical High nickel content 3/4" precision ground
hot rolled steel plate
- Plate Aluminized steel
- Burners Front, sides, trough and
splashguard, stainless steel
- Cabinet Back, aluminized steel

STANDARD ACCESSORIES

- Stainless steel sides
- Pressure regulator
- 4" Adjustable chrome plated legs

OPTIONS AND ACCESSORIES

- Removable cutting board and
bracket assembly
- Stainless steel stands

DIMENSIONS

24" MODELS

Overall	SLMG 24X24	SLMG 24X36	SLMG 24X48
■ (W) Width	24.25"	36.25"	48.25"
■ Height	17.25"	17.25"	17.25"
■ Depth	29.5"	29.5"	29.5"
Plate			
■ Width	24"	36"	48"
■ (D) Depth	24"	24"	24"
NG BTUH	60,000	90,000	120,000
LP BTUH	60,000	90,000	120,000

Specifications subject to change without notice.
SS# 204 Revised 8/05
Printed in the U.S.A.

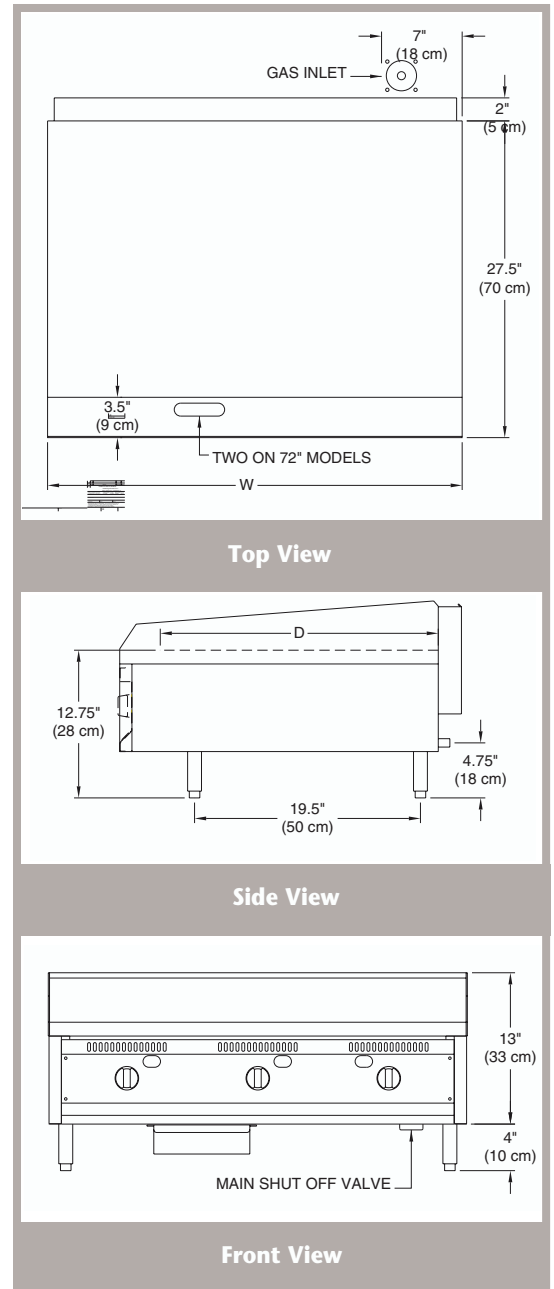

Anetsberger Brothers, Inc. ■ Dependable Foodservice Equipment
180 North Anets Drive ■ Northbrook, Illinois 60062
1-800-837-2638 ■ Fax 847-272-1943 ■ www.anets.us