

Turbo air
REFRIGERATOR MANUFACTURER
 more durable, convenient, beautiful

1250 Victoria St
 Carson, CA 90746
 Tel. 310-900-1000
 Fax. 310-900-1077
www.turboairinc.com

Project :	
Model # :	
Item # :	Qty :
Available W/H :	
Approval :	

Combination Bakery Case

Display Cases
 Dry/Refrigerated Combination Cases

Model : TCB-5R



FEATURES / BENEFITS

- ENVIRONMENTALLY FRIENDLY, EFFICIENT REFRIGERATION SYSTEM**
 Turbo Air's refrigerators are designed with oversized and balanced environmentally friendly R-134A (CFC Free) refrigeration. These include large evaporators and condensers for faster cooling and balanced temperature throughout the cabinet.
- HIGH-DENSITY POLYURETHANE INSULATION**
 The entire cabinet structure is foamed-in-place using high density, CFC free polyurethane insulation.
- FRAMELESS GLASS AND ELEGANT EURO DESIGN**
 The frameless all sided glass display cases provide full product visibility to optimize display effects and increase impulse sales. Its elegant contemporary euro design will not only enhance any store atmosphere but also will keep product presentation at its best and beautiful.
- FOUR POINT LEVELING SYSTEM**
- EASY ACCESS CONTROL PANEL**
- LIFT-UP, PNEUMATIC CYLINDER-ASSISTED CURVED TEMPERED FRONT GLASS**
- REFRIGERATED BAKERY CASE HOLDS AVG. 38°F ~ 40°F FOR FRESHER BAKERY PRODUCTS**
- SLOPED REAR DOORS FOR PRODUCT ACCESS**
- REAR ACCESS OF COMPRESSOR COMPARTMENT FOR QUICK AND EASY SERVICE**
- INDEPENDENTLY WIRED SHELF LIGHTS**
- 5" CASTERS STANDARD**
- CANTILEVERED WIRED SHELVES ADJUSTABLE UP AND DOWN, TILTED**
- RECOMMENDED OPERATING CONDITIONS**
 TB models are designed to operate in environments where temperature & humidity do not exceed 75°F and 55% relative humidity.
- 304 STAINLESS STEEL FLOOR AND AIR FLOW GRILLE**



Model	CU./FT.	# of Shelves	HP	AMPS	Crated Weight (lbs.)	L x D x H [†] (inches)
TCB-5R	18.6	4	1/3	9	1,004	59 1/4 x 37 3/8 x 47 1/4

Combination Bakery Case

Display Cases
Dry/Refrigerated Combination Cases

Model : TCB-5R

ELECTRICAL DATA	
Voltage	115/60/1
Plug Type	Ⓢ NEMA-5-20P
Full Load Amperes	9
Compressor HP	1/3
Refrigerant	R-134A
Cord Length (ft.)	9
DIMENSIONAL DATA	
Net Capacity cu. ft.	18.6 (D-9.3, R-9.3)
Ext. Length Overall in.	59 1/4 (1505mm)
Ext. Depth Overall in.*	37 3/8 (950mm)
Ext. Height Overall in.†	47 1/4 (1200mm)
Int. Length Overall in.	(D)27 1/8(690mm) (R)27 1/4(692mm)
Int. Depth Overall in.	26 1/2 (673mm)
Int. Height Overall in.	26 1/8 (665mm)
Crated Weight lbs.	754
# of Shelves	4
Self Size	(Top) 26 1/4 x 16 7/8 (Bottom) 26 3/4 x 25 5/8

Design and specifications subject to change without notice.
Actual shipping weight may differ due to extra packing materials for product protection.
*Depth does not include 2-5/8" for door handle.
† Height does not include 5-1/4" caster height.

- **WARRANTY : 1 Year Parts and Labor Warranty**
Additional 4 Year Warranty on Compressor

- **SELF-CONTAINED SYSTEM, NO PLUMBING REQUIRED**
- **SIMPLE PLUG-IN INSTALLATION**

PLAN VIEW

(unit : inch)

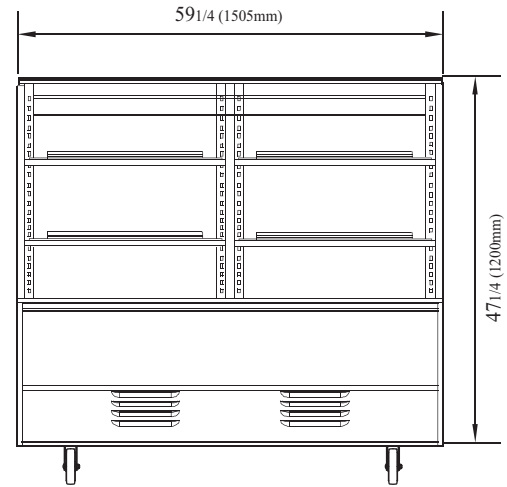

PLAN VIEW

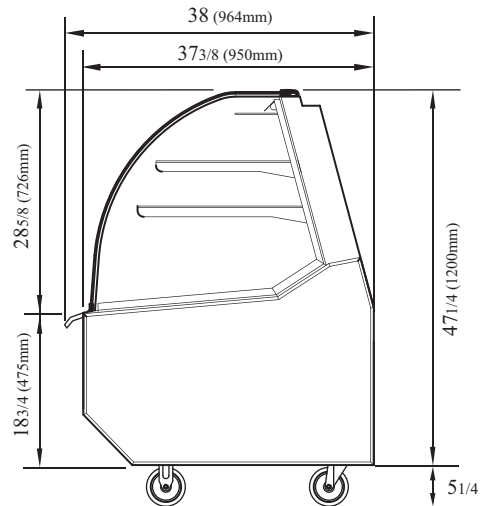

SIDE VIEW

Ver.201203



- Turbo Air : 800-627-0032 ■ GK : 800-500-3519
- Warranty : 800-381-7770 ■ AC : 888-900-1002

