



TRUE FOOD SERVICE EQUIPMENT, INC.

St. Charles Industrial Center • P.O. Box 970 • O'Fallon, Missouri 63366
(636)240-2400 • FAX (636)272-2408 • (800)325-6152 • www.truemfg.com

Project Name: _____

AIA #

Location: _____

SIS #

Item #: _____ Qty: _____

Model #: _____

TM (Top Mount) Series



TM-24F

Top Mount Reach-In Freezers

TM-24F, TM-52F

SPECIFICATIONS / FEATURES

DOORS:

- 300 series stainless steel exterior with white aluminum interior to match cabinet liner. Doors extend full width of cabinet shell. Door gaskets of one piece construction.
- Lifetime guaranteed adjustable torsion type closure system with aluminum block supports. The face of each door fitted with a 12" long recessed handle with sheetmetal interlock. Handles are foamed-in-place to insure permanent attachment.

INSULATION:

- Entire cabinet structure and doors insulated using foamed-in-place CFC free polyurethane foam.

SHELVING:

- Adjustable vinyl coated wire shelves (3 per section). Shelves capable of supporting up to 250 lbs.
- Full height shelf support pilasters, with double oblong holes on 1/2" centers. Pilasters made of the same material as cabinet interior. Four (4) chrome plated, stainless steel shelf clips to be included for each shelf.

LIGHTING:

- Incandescent interior lighting. Light(s) activated by rocker switch mounted above door(s).

REFRIGERATION SYSTEM:

- Refrigeration system factory balanced using CFC free R404A refrigerant.

- Top mounted condensing unit.

- Factory pre-engineered capillary tube system with oversized condenser and evaporator to reduce product pull down time and to consistently maintain -10°F interior cabinet temperature. (non-adjustable capillary tube system superior to problematic expansion valve)

- Defrost system time initiated, temperature terminated.

- Automatic evaporator fan motor delay during defrost cycle.

- Large evaporator and coil heater permit short defrost cycle.

- Evaporator - epoxy coated at the time of manufacture to eliminate the potential of corrosion.

ELECTRICAL CHARACTERISTICS:

- Unit completely pre-wired at factory, and ready for final connection to appropriate outlet (see diagram below and NEMA listing next page. A cord and plug set to be included.

- A sole use circuit is required.

TRUE's Top Mount series provides the maximum interior capacity in the least amount of floor space.

SPECIFICATIONS / FEATURES

CABINET CONSTRUCTION:

- 300 series stainless steel front grill, shroud and doors. Anodized quality aluminum exterior ends and back.
- NSF approved, white vinyl coated aluminum and 300 series stainless floor with coved corners.
- Rear wall airflow guard prevents frozen product from blocking optimal airflow.
- Barrel lock standard for each door. Locks keyed alike. Digital exterior mounted temperature monitor.
- Cabinet mounted on a welded, galvanized frame rail, painted for additional corrosion protection. Frame rail fitted with 4" diameter castors, front castors include brakes.

Also available:

- Glass Door Models
- Half Door Models
- Refrigerator Models
- Deep Top Mounts



TM-24F
115/60/1
NEMA-5-15R



TM-52F
115/60/1
NEMA-5-20R

Remote cabinets available 14% off list (condensing units supplied by others). Consult factory technical service dept. for BTU information.

Specifications subject to change without notice.

Printed in U.S.A.



APPROVALS:

2/03

Exceptions:



TM-Series: Top Mount Reach-In Freezers

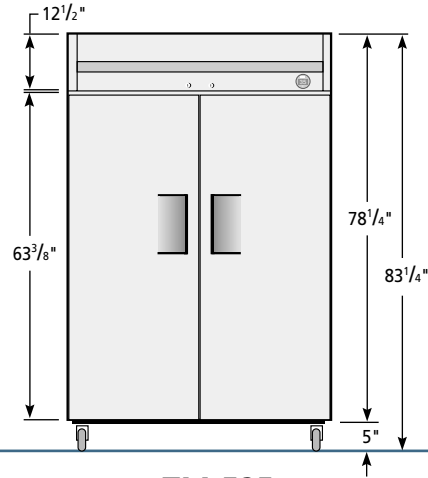
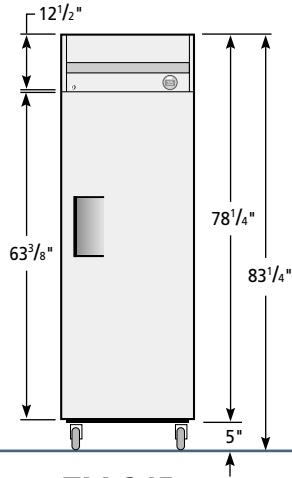
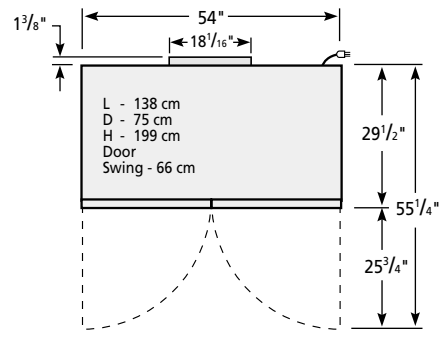
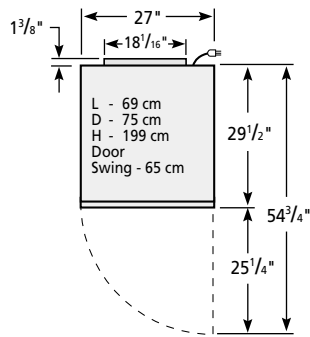

TM-24F

TM-52F

Rough-In Data

Model	Doors	Capacity (Cu. Ft)	# of Shelves	Dimensions (inches)			HP	Volts	PH	Amps	NEMA Config.	Cord Length (feet)	Crated Weight
				L	D †	H*							
TM-24F (1, 2)	1	24	3	27	29 1/2	78 1/4	1/2	115	1	9.6	5-15	9	332
TM-52F (1, 2, 3)	2	52	6	54	29 1/2	78 1/4	3/4	115	1	14.0	5-20	9	488

- (1) Available in refrigerator model.
- (2) Available with stainless steel half door refrigerator model.
- (3) Available in glass door model.
- * Height does not include 5" for castors or 6" for optional legs.
- † Depth does not include 1 3/8" for upper rear condensate enclosure.

Specifications subject to change without notice.

Standard Features

- Oversized and balanced, environmentally friendly R404A refrigeration system holds -10°F.
- 300 series stainless steel doors & front.
- Interior - NSF approved, white vinyl coated aluminum sides and top, 300 series stainless steel floor with coved corners.
- Anodized quality aluminum top, sides and back.
- Standard backguard improves airflow.
- Recessed handles (lifetime guarantee).
- Exterior mounted digital temperature monitor.
- Door locks standard.
- Magnetic door gaskets.
- Adjustable vinyl coated wire shelves.
- Epoxy coated evaporator.
- Incandescent interior lighting.
- 4" diameter swivel castors standard equipment - locking castors provided for front set.
- Large evaporator and coil heater permit short defrost cycle.
- Defrost system time initiated, temperature terminated.
- Automatic evaporator fan motor delay during defrost cycle.

- Minimum wattage heater in cabinet frame and door.
- Foamed-in-place polyurethane high density cell insulation (CFC free).
- 1 year parts & labor warranty (USA).
- 5 year compressor warranty.

Optional Accessories

- Available with 6" stainless steel or optional seismic legs.
- Additional shelves available

	Model	Front	Right	Plan	3D
	TM-24F	TFEY20E	TFEY75S	TFEY03P	TFEY753
	TM-52F	TFEY21E	TFEY75S	TFEY76P	TFEY763

Clearance Required For Coolers (USA)		
Sides Inches/mm	Top Inches/mm	Rear Inches/mm
0 / 0	open	3 / 77



TRUE FOOD SERVICE EQUIPMENT