



Project:	_____
Location:	_____
Item #:	_____
Quantity:	_____

Worktop Refrigerators

Two Section Model with Doors VUR-60-SST

Doors, tops and interior floor of stainless steel.
Aluminum ends and interior.



Standard Features:

- Stainless Steel Doors, Tops and Interior Bottom Construction Provides Durable Lasting Finish
- Durable Aluminum Interior Sides and Rear for Easy Cleaning
- Models are Front-Breathing and Recessible to Enable Zero Clearance Placement or Placement in Limited Access Areas
- Holds Food Safely and Assures Fresher Food
- Interior Thermometer Consistently Monitors Temperature
- Self-Closing Door with Replaceable One Piece Magnetic Gasket Maintains Positive Seal
- Horizontal Recessed Heavy-Duty Handles Provide Quicker, Easier Access to Cabinets
- Heavy-Duty, Epoxy Coated Steel Shelves Accept Heavy Loads and Offer Easy Clean-up
- Adjustable Shelves Provide Storage Flexibility
- Energy Saving, High Density, Polyurethane Foam Insulation Promotes Cold Retention
- Anti-Corrosion Coated Evaporator Coil Assures Lasting Performance
- Automatic Condensation Evaporation System Eliminates the Need for Floor Drain
- Balanced Energy Efficient Refrigeration System

- Environmentally Friendly R-134a Refrigerant
- Plugs into Standard 115 V Outlets - Cord and Plug Attached for Easy Installation
- 5" Heavy-Duty Swivel Casters with Brakes Provide Mobility
- Completely Finished and Enclosed Cabinet Back
- Meets Tough NSF Standard 7, 41° F

Optional Features and Accessories:

- 3" Heavy-Duty Swivel Casters with Brakes
- 6" Adjustable Stainless Steel Legs
- Single and Double Overshelf
- Stainless Steel Back
- Door Mounted Dial Thermometer
- Cylinder Locks

Approvals:		Victory Refrigeration specification sheets are available online at www.victory-refrig.com .
------------	--	---

CHARACTERISTICS	VUR-60-SST
Width, Overall	60
Depth, Overall	30
Height, Overall	35 1/2
Height, Work Area	35 1/2
Capacity Net (cubic feet)	16
No. of Full Doors	2
No. of Shelves	4
Cabinet Voltage	115/60/1
Condensing Unit Voltage	115/60/1
Condensing Unit Size (HP)	1/3
Total Amperes	8.8
NEMA Receptacle Required	5-15R

Crated dim. & wts.	Ht.	Width	Depth	Lbs.
VUR-60-SST	48 1/2	65 1/2	39 1/2	390

Dimensional tolerance $\pm 1/4"$ Metric dimensions (MM)

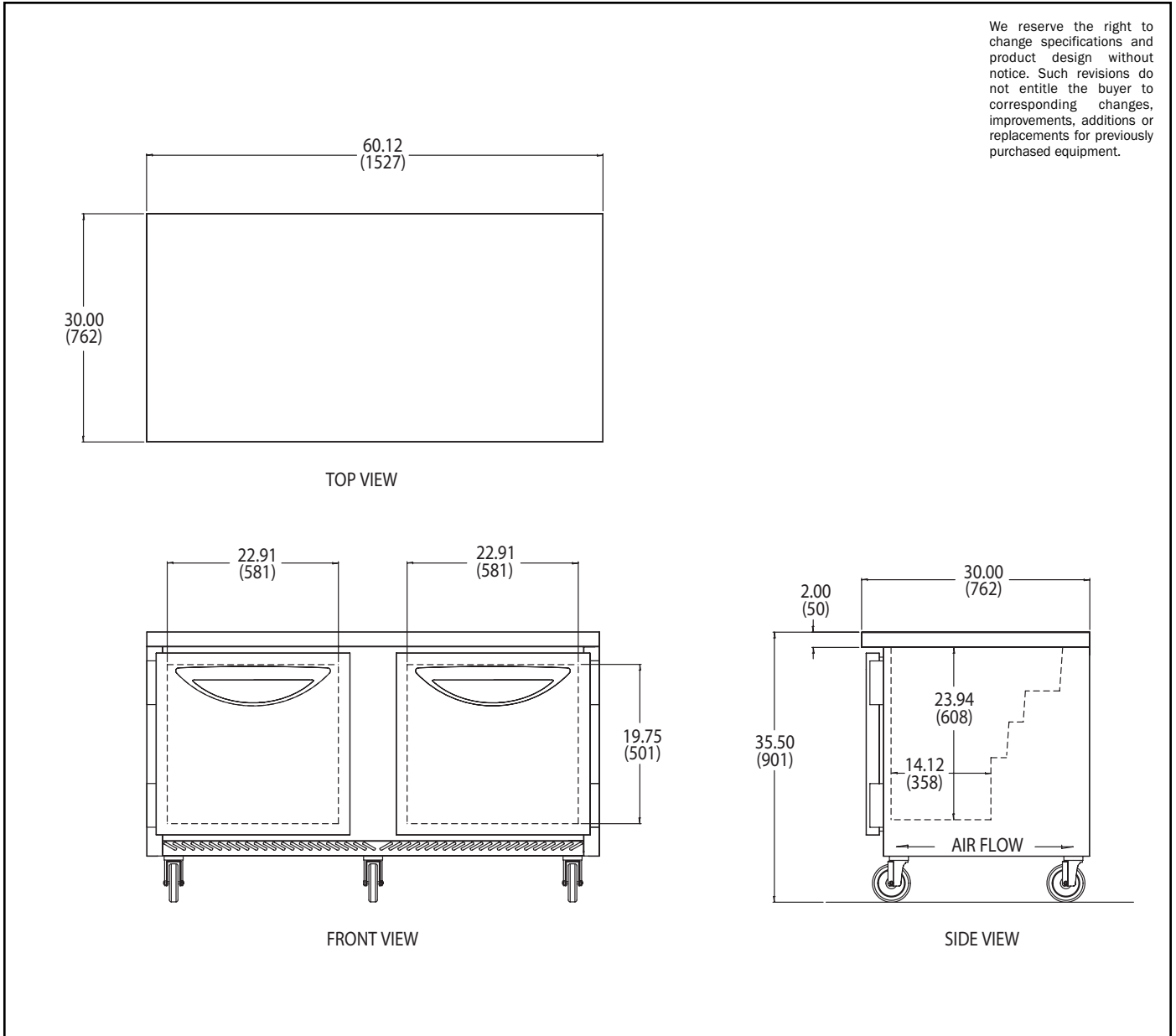

We reserve the right to change specifications and product design without notice. Such revisions do not entitle the buyer to corresponding changes, improvements, additions or replacements for previously purchased equipment.

Continuous product development may necessitate specification changes and design without notice.



Victory participates in the KCL CADalog, the most current source of CAD symbols for foodservice designers worldwide. Symbols include standard equipment in plan, side, front and 3-D views, layered for FEDA/FCSI recommended guidelines.