



BEVERAGE-AIR

3779 Champion Blvd., Winston-Salem, NC 27105
1-888-845-9800 Fax# 1-336-245-6453
<http://www.Beverage-Air.com>

CUSTOMER'S CHOICE FOR A HOT KITCHEN
Tested & Certified to Ambient Class of 100°F

Item No. _____
Quantity _____

**29" DEPTH
WORKTOP FREEZER
FOOD PREPARATION SERIES
GLASS DOOR MODEL**

**MODELS:
WTF27A-25**

3 Year Parts/Labor Warranty Additional 2 Year Compressor Warranty

WTF—SERIES - GLASS DOOR WORKTOP UNITS

Versatile, compact (29" deep) models with stainless steel work tops and frozen storage of food products. Working height* is 35 1/2".

CABINET CONSTRUCTION

Heavy duty construction includes stainless steel on front and sides grille. Worktop is stainless steel with 4" removable backsplash. Cabinet back and bottom are galvanized steel. Interior liner is made of aluminum for longer lasting corrosion protection. Interior thermometer is standard.

Cabinets are insulated with foamed-in-place polyurethane insulation of 2" minimum thickness. Work tops are 2 1/2". Glass doors are mounted to cabinet on self-closing, cartridge style hinges with 120° stay open feature. Door openings include low wattage, anti-condensate heaters. A plug-in type vinyl magnetic gasket is attached to each door for positive seal. Interior arrangement includes 2 steel wire epoxy coated shelves behind each door, adjustable in 1/2 inch increments.

REFRIGERATION

Forced air refrigeration systems use capillary tube to meter refrigerant. Temperatures are held at zero and below. Refrigerant used is R404A. Automatic defrost is standard. Automatic (non-electric) condensate evaporator is provided.

ELECTRICAL

Units wired at factory and ready for connection to a 115/60/1 phase, 15 amp dedicated outlet. 8' long cord and plug set included.

SPECIAL FEATURES

- Cartridge style door hinges provides positive seal & eliminates door sagging issues (excludes glass door and some special units).
- 6" casters, two with brakes standard.
- Optional 6" legs or 3" casters available



WTF27A-25

ELECTRICAL CONNECTION

Units pre-wired at factory and include 8' long cord and plug set.



115/60/1
NEMA-5-15P

***Note:** Overall heights of casters may vary with different types of casters depending upon caster manufacturer designations.

Available From:



Model Specified _____	Store# _____
Location _____	Quantity _____



BEVERAGE-AIR

**Standard Worktop
Freezer Cabinets
Models: WTF27A-25**

MODEL	WTF27A-25
EXTERNAL DIMENSIONAL DATA	
Length Overall (inches)	27"
Length Overall (mm)	686
Depth Overall (inches) - Less handle	29 1/4"
Depth Overall (mm) - Less handle	743
Height Overall—on 6" casters (inches)*	39 1/2"
Height Overall—on 6" casters (mm)*	1003
Depth with Door Open 90 °	53 3/4"
Clear Door Opening (inches)	22 1/2" x 23 1/4"
Number of doors	1
INTERNAL DIMENSIONAL DATA	
NET Capacity (cubic ft.)	7.3
NET Capacity (Liters)	207
Internal Length Overall (inches)	23"
Internal Length Overall (mm)	584
Internal Depth Overall (inches)	25"
Internal Depth Overall (mm)	635
Internal Height Overall (inches)	23"
Internal Height Overall (mm)	584
Number of shelves	2
ELECTRICAL DATA	
Full Load Amperes 115/60/1	6.0
ENERGY CONSUMPTION (KWH)	
	7.5
REFRIGERATION DATA	
Horsepower	1/4
WEIGHT DATA	
Gross Weight (Crated lbs)	166
Gross Weight (Crated kg)	75

PLAN VIEWS

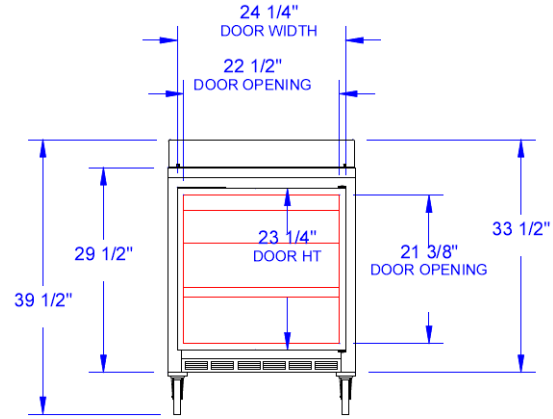

FRONT VIEW

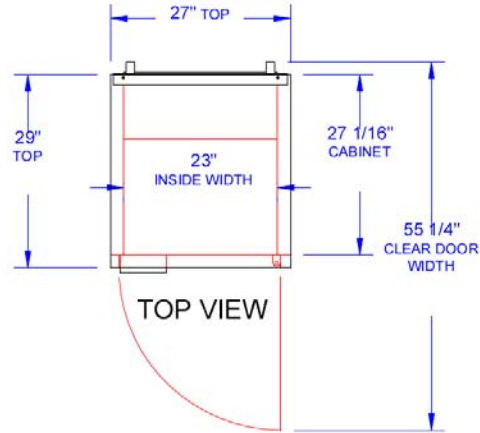

TOP VIEW

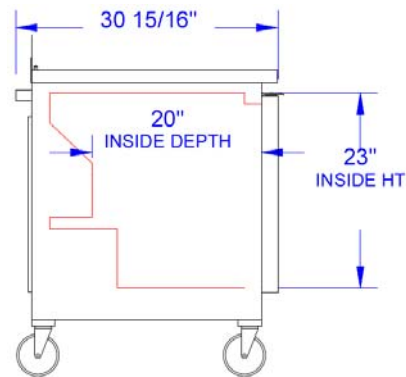

LEFT SIDE VIEW

***Note:** Overall heights of casters may vary with different types of casters depending upon caster manufacturer designations.



BEVERAGE-AIR® CORPORATION

3779 Champion Blvd. • Winston-Salem, NC 27105 USA • (336) 245-6400 • Fax (336) 245-6453 • (888) 845-9800 • www.beverage-air.com

Specifications are subject to change without prior notice. 08/14